



# **DATA SHEET**

## **- Preliminary -**

# **Surface Acoustic Wave Filter**

- **Application : B39Rx & B41Rx**
- **Model : SFRG00FBB02**
- **Center Frequency : 1900 / 2605 [MHz]**



**WISOL CO., LTD.**

373-7, GAJANG-DONG, OSAN-SI,  
GYEONGGI-DO, KOREA, 18103

<http://www.wisol.co.kr>

E-mail: [sales@wisol.co.kr](mailto:sales@wisol.co.kr)

# 1. OUTLINE DRAWING & RECOMMENDED PCB

< Outline Drawing >

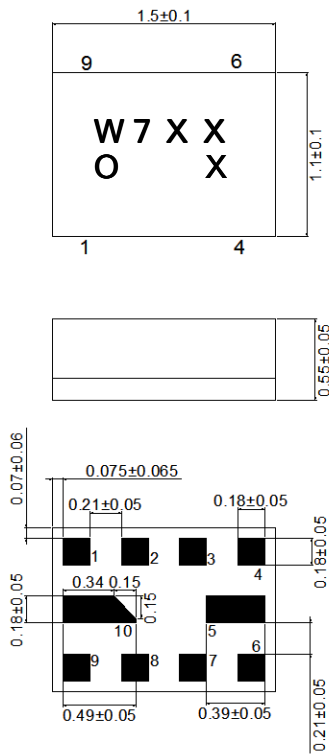

No.	Function
1	B39/B41 Unbalanced Input
9	B41 Unbalanced Output
6	B39 Unbalanced Output
1,3,4,5,7,8,10	GND

[Unit: mm]

# 2. TEST FIXTURE

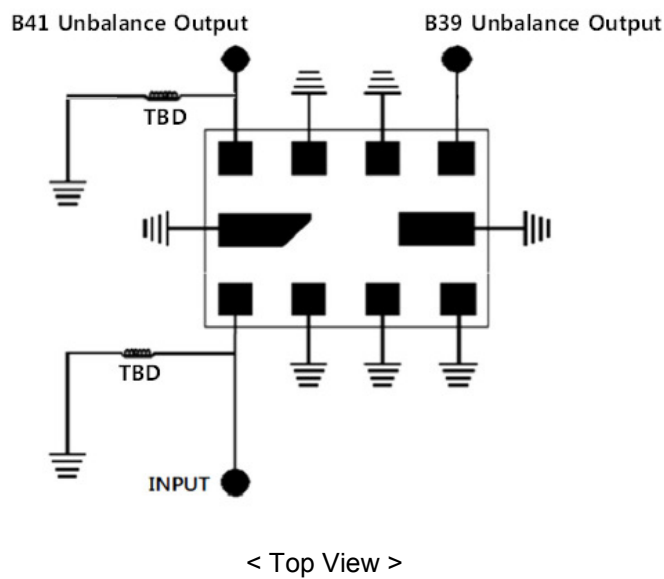

### 3. PERFORMANCE

#### 3-1. MAXIMUM RATINGS

CHARACTERISTICS	RATINGS	UNITS
DC Permissive Voltage	5	V
Maximum Input Power	10	dBm
Operating Temperature Range	-30 ~ +85	°C
Storage Temperature Range	-40 ~ +85	°C

#### 3-2. ELECTRICAL CHARACTERISTICS

##### 3-2-1. TABLE

Ta = - 30 ~ + 85 °C

\*1. PCB loss is de-embedded

ITEM	UNIT	LTE B39				LTE B41			
		Freq. Range [MHz]	Min.	Typ. (25°C)	Max.	Freq. Range [MHz]	Min.	Typ. (25°C)	Max.
Insertion Loss	dB	1880 ~ 1920		1.4	TBD	2555 ~ 2655		2.3	TBD
Inband Ripple	dB	1880 ~ 1920		0.5	TBD	2555 ~ 2655		0.8	TBD
Input VSWR	-	1880 ~ 1920		1.6	TBD	2555 ~ 2655		1.8	TBD
Output VSWR	-	1880 ~ 1920		1.6	TBD	2555 ~ 2655		1.8	TBD
Absolute Attenuation	dB	1 ~ 1710	TBD	38		10 ~ 1564	TBD	38	
	dB	1710 ~ 1785	TBD	32		1565 ~ 1615	TBD	37	
	dB	1795 ~ 1820	TBD	39		1616 ~ 2400	TBD	34	
	dB	1950 ~ 1980	TBD	10		2401 ~ 2483	TBD	31	
	dB	1980 ~ 2025	TBD	28		2775 ~ 4991	TBD	28	
	dB	2025 ~ 2400	TBD	35		4992 ~ 5380	TBD	29	
	dB	2400 ~ 2500	TBD	37					
	dB	2500 ~ 6000	TBD	31					
Termination Impedance	Input: Unbalanced 50 ohm // TBD nH Output: Band39 50ohm / Band41 Unbalanced 50 ohm // TBD nH								

3-2-2. GRAPH

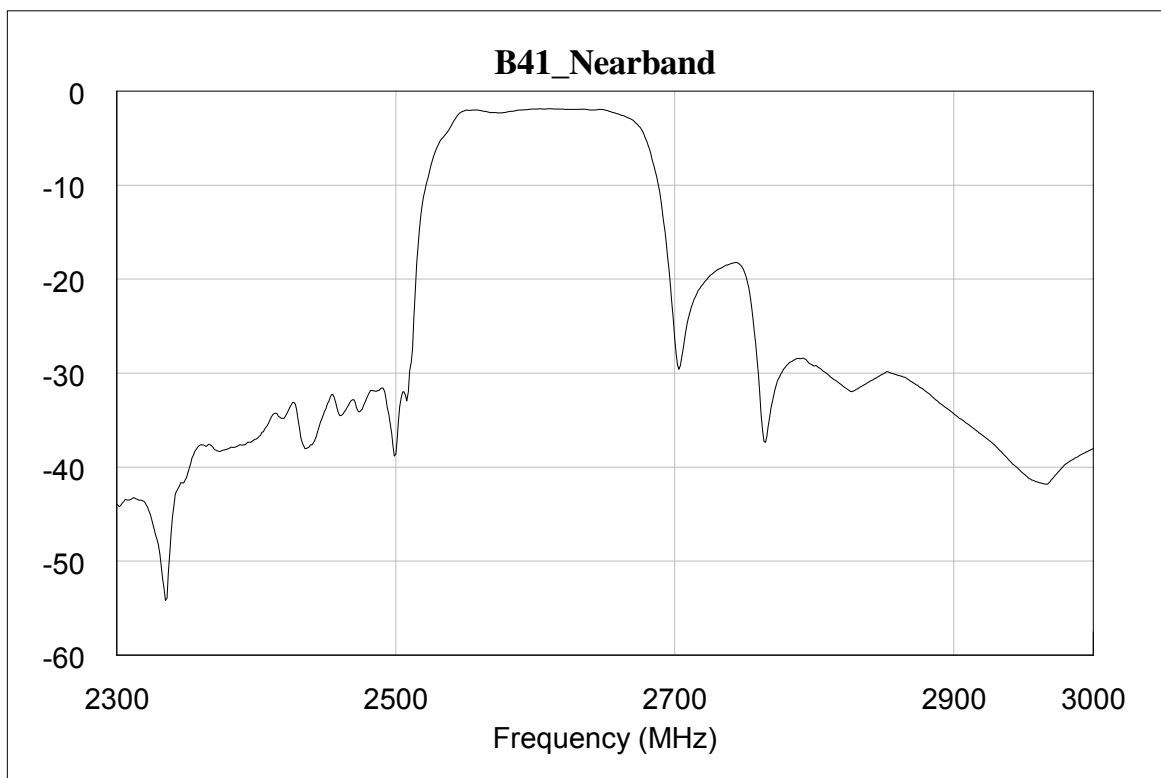
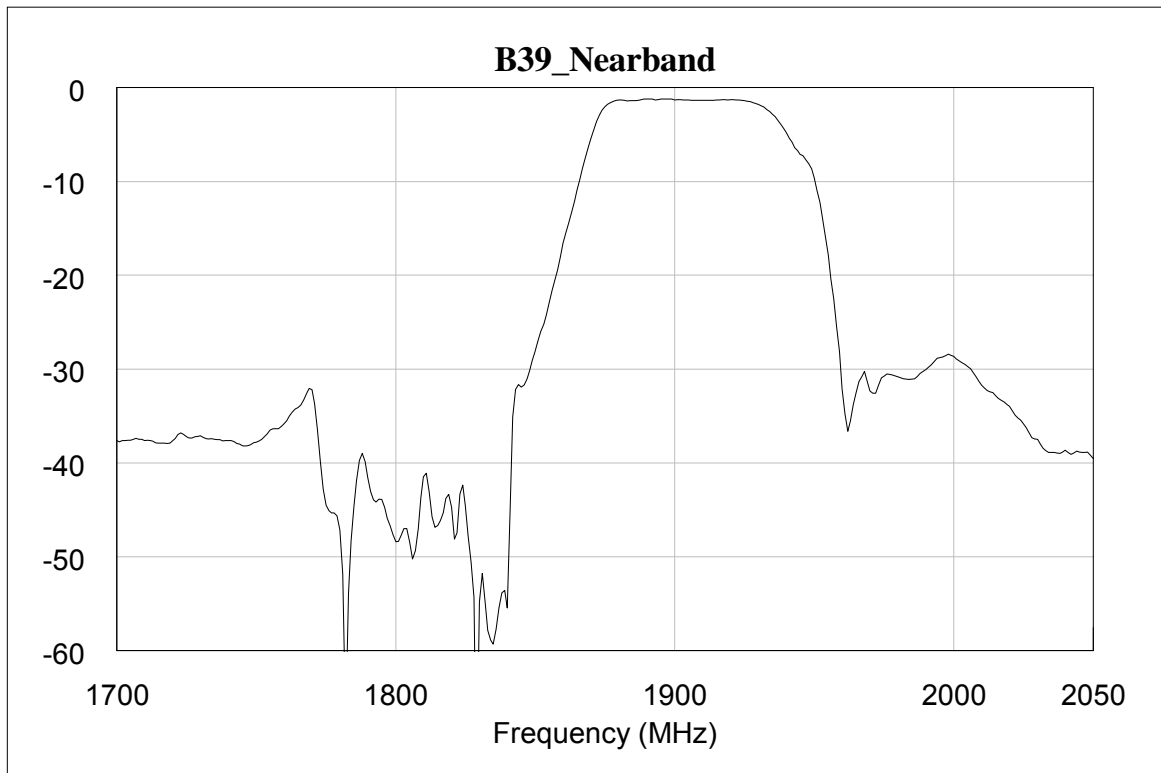

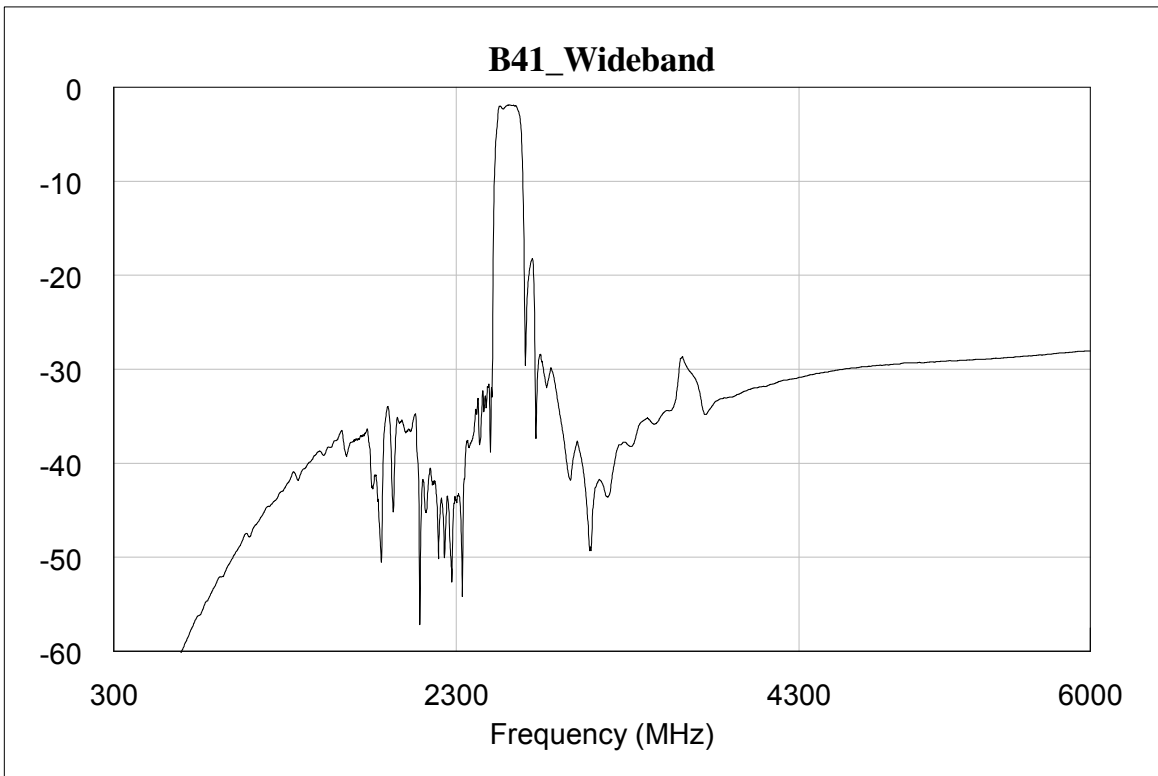
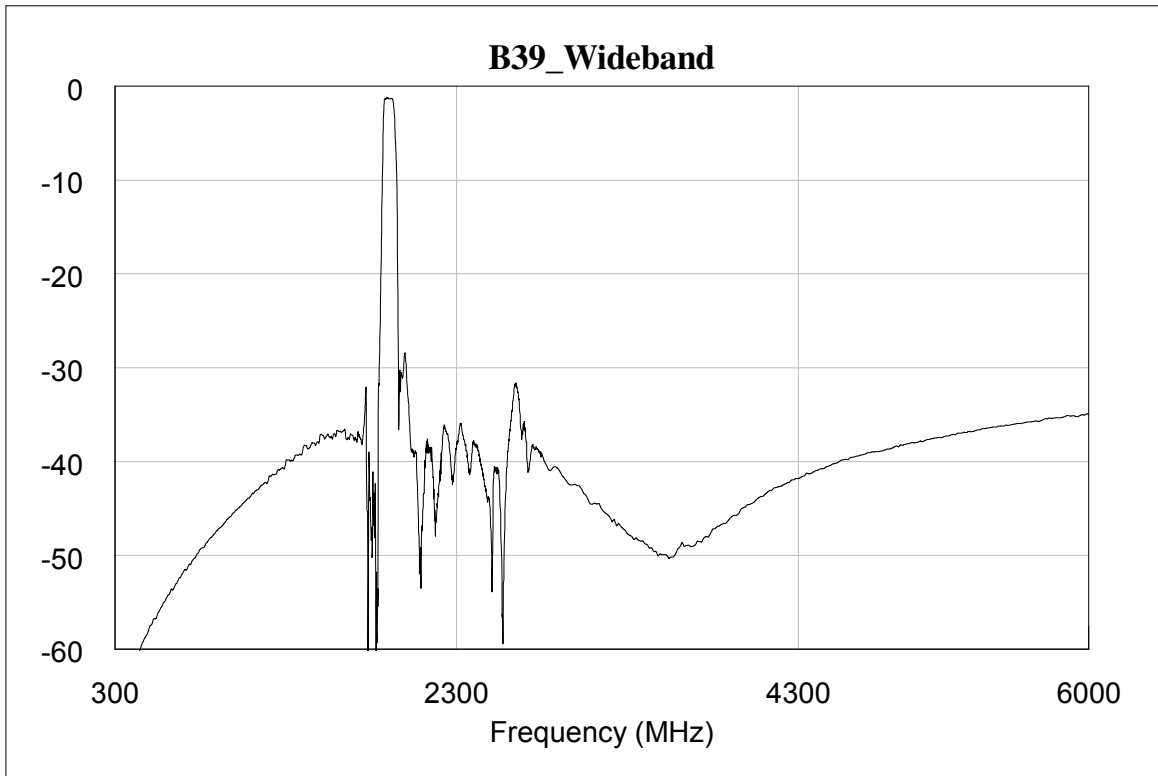

## 4. PACKING

### 4-1. DIMENSIONS

- Carrier Tape [Unit: mm]

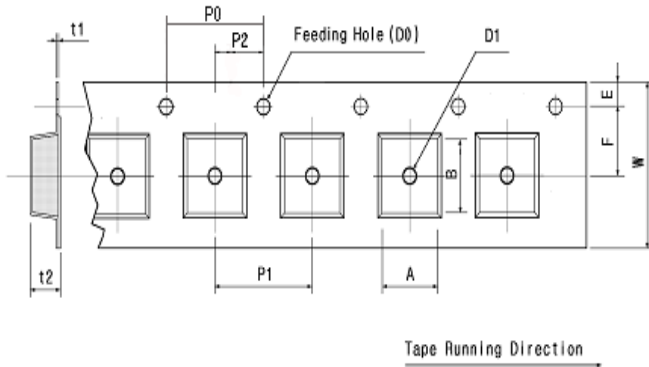

A	B	D0	D1
1.30	1.65	Ø1.50	Ø0.50
+ 0.05	+ 0.05	+ 0.10	+ 0.05
- 0.05	- 0.05	- 0.00	- 0.05
E	F	P0	P1
1.75	3.50	4.00	4.00
+ 0.10	+ 0.05	+ 0.10	+ 0.10
- 0.10	- 0.05	- 0.10	- 0.10
P2	t1	t2	W
2.00	0.254	1.00	8.00
+ 0.05	+ 0.02	+ 0.07	+ 0.30
- 0.05	- 0.02	- 0.07	- 0.10

- Reel [Unit: mm]

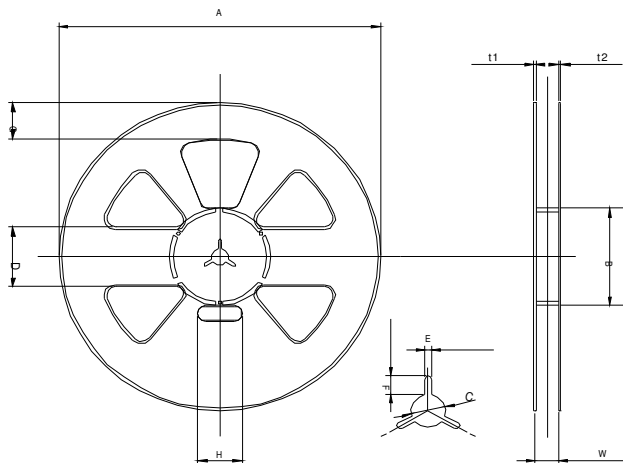

A	B	C	D
Ø258.0	Ø81.0	Ø13.0	50.0
+1.0	+1.0	+0.5	+0.8
-0.5	-1.0	-0.5	-0.8
E	F	G	H
2.2	7.0	30.0	35.0
+0.3	+0.5	+0.8	+1.0
-0.3	-0.5	-0.8	-1.0
t1	t2	W	
1.8	1.5	9.0	
+0.5	+0.5	+1.0	
-0.5	-0.5	-0.5	

- The product shall be packed properly not to be damaged during transportation and storage.

### 4-2. REELING QUANTITY

10 inch reel: 8,000 pcs/reel

### 4-3. TAPING STRUCTURE

The tape shall be wound around the reel in direction shown below.

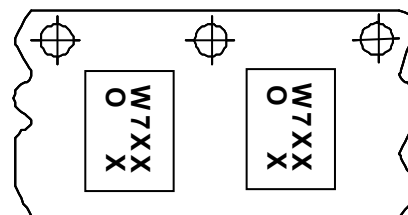
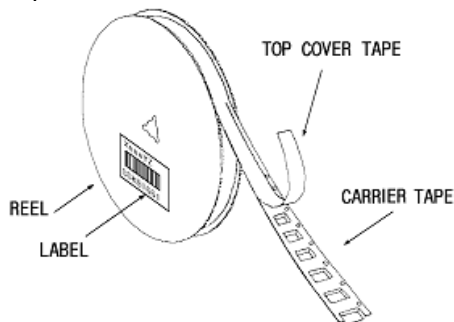

Tape Running direction

