



# SGM3732

## PWM Dimming, 38V Step-Up LED Driver

### GENERAL DESCRIPTION

The SGM3732 is a versatile constant current LED driver with a high efficiency step-up converter architecture. The low-side power MOSFET is integrated in the device, significantly shrinking the overall PCB layout area and minimizing the total number of external components. Unique technology and high 1.35A current limit allow SGM3732 to drive up to 38V output (10 LEDs in series). Alternatively, SGM3732 can deliver 260mA total current with 3 series LEDs per string. It can also maximize the current capability while achieving high conversion efficiency. The optimized 1.1MHz switching frequency results in reduced conduction loss and small external component size. Digital PWM dimming interface is integrated to adjust LED current. The PWM frequency is in the range from 2kHz to 60kHz.

Various protection features are built into the SGM3732, including cycle-by-cycle input current limit protection, open LED (output over-voltage) protection and thermal shutdown protection. The leakage current in shutdown mode is less than 1 $\mu$ A.

The SGM3732 is available in Green TSOT-23-6 package. It operates over an ambient temperature range of -40°C to +85°C.

### FEATURES

- **Wide Output Range: Up to 10 Series LEDs**
- **Integrated 40V High Current Switch (1.35A Limit)**
- **2.7V to 5.5V Input Voltage Range**
- **High Efficiency PWM Converter**
- **Low 200mV Feedback Voltage**
- **500k $\Omega$  Pull-Down Resistor on CTRL Pin**
- **2kHz to 60kHz PWM Dimming Frequency**
- **38V Open LED Protection**
- **1.1MHz Switching Frequency**
- **Integrated Soft-Start Function**
- **Less than 1 $\mu$ A Shutdown Current**
- **Simple, Small Solution Size**
- **Available in Green TSOT-23-6 Package**
- **-40°C to +85°C Operating Temperature Range**

### APPLICATIONS

LED Backlighting  
Mobile Phones  
Handheld Devices  
Digital Photo Frames  
Automotive Navigation

**PACKAGE/ORDERING INFORMATION**

MODEL	PACKAGE DESCRIPTION	SPECIFIED TEMPERATURE RANGE	ORDERING NUMBER	PACKAGE MARKING	PACKING OPTION
SGM3732	TSOT-23-6	-40°C to +85°C	SGM3732YTN6G/TR-V1	SKAXX	Tape and Reel, 3000

NOTE: XX = Date Code.

Green (RoHS & HSF): SG Micro Corp defines "Green" to mean Pb-Free (RoHS compatible) and free of halogen substances. If you have additional comments or questions, please contact your SGMICRO representative directly.

**MARKING INFORMATION**

**SKA X X**

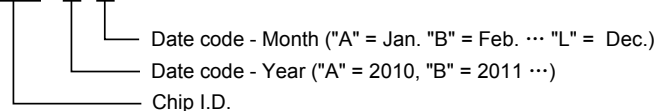

For example: SKAFA (2015, January)

**ABSOLUTE MAXIMUM RATINGS**

- Input Voltage,  $V_{IN}$ ..... -0.3V to 6V
- High Voltage Nodes, SW, VOUT ..... -0.3V to 40V
- Other Pins, FB, CTRL.....-0.3V to  $V_{IN} + 0.3V$
- Package Thermal Resistance
- TSOT-23-6,  $\theta_{JA}$  ..... 120°C/W
- Junction Temperature .....+150°C
- Storage Temperature Range .....-65°C to +150°C
- Lead Temperature (Soldering, 10sec) .....+260°C
- ESD Susceptibility
- HBM..... 4000V
- MM..... 200V

**RECOMMENDED OPERATING CONDITIONS**

- Input Voltage Range .....2.7V to 5.5V
- Operating Temperature Range .....-40°C to +85°C

**OVERSTRESS CAUTION**

Stresses beyond those listed may cause permanent damage to the device. Functional operation of the device at these or any other conditions beyond those indicated in the operational section of the specification is not implied. Exposure to absolute maximum rating conditions for extended periods may affect reliability.

**ESD SENSITIVITY CAUTION**

This integrated circuit can be damaged by ESD if you don't pay attention to ESD protection. SGMICRO recommends that all integrated circuits be handled with appropriate precautions. Failure to observe proper handling and installation procedures can cause damage. ESD damage can range from subtle performance degradation to complete device failure. Precision integrated circuits may be more susceptible to damage because very small parametric changes could cause the device not to meet its published specifications.

**DISCLAIMER**

SG Micro Corp reserves the right to make any change in circuit design, specification or other related things if necessary without notice at any time.

**PIN CONFIGURATION**

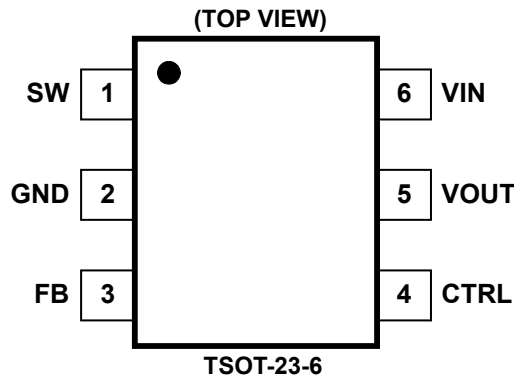

**PIN DESCRIPTION**

PIN	NAME	FUNCTION
1	SW	Converter Switching Node.
2	GND	Ground.
3	FB	Output Feedback Pin Regulated at 200mV.
4	CTRL	Control Pin of the Boost Regulator. It is a multi-functional pin which can be used for enable control and digital PWM dimming.
5	VOUT	Output and Over-Voltage Protection Pin.
6	VIN	IC Supply. Connect VIN to a supply voltage between 2.7V and 5.5V.

**TYPICAL APPLICATION**

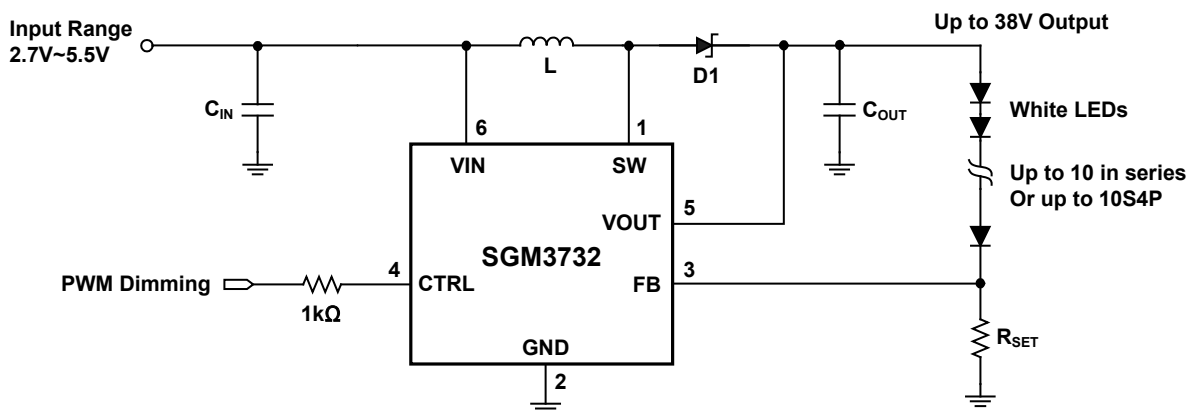

Figure 1. Typical Application Circuit

**ELECTRICAL CHARACTERISTICS** <sup>(1)</sup>

( $V_{IN} = 3.6V$ ,  $L = 10\mu H$ ,  $C_{IN} = 10\mu F$ ,  $C_{OUT} = 0.47\mu F$ , Full =  $-40^{\circ}C$  to  $+85^{\circ}C$ , typical values are at  $T_A = +25^{\circ}C$ , unless otherwise noted.)

PARAMETER	SYMBOL	CONDITIONS	TEMP	MIN	TYP	MAX	UNITS
<b>IC SUPPLY</b>							
Input Voltage Range	$V_{IN}$		Full	2.7		5.5	V
Input Under-Voltage Lockout	UVLO	Rising edge	$+25^{\circ}C$		2.5	2.6	V
UVLO Hysteresis	$V_{HYS}$		$+25^{\circ}C$		0.15		V
Quiescent Current (Non Switching)	$I_Q$	$V_{FB} = 0.4V$	$+25^{\circ}C$		0.20	0.35	mA
Operating Current (Switching)		$V_{FB} = 0V$	$+25^{\circ}C$		0.72	1.5	mA
VIN Pin Shutdown Current	$I_{SHDN}$	$V_{EN} = 0V$	$+25^{\circ}C$		0.1	1	$\mu A$
<b>STEP-UP CONVERTER</b>							
Voltage Feedback Regulation Voltage	$V_{REF}$		Full	192	200	212.5	mV
Voltage Feedback Regulation Voltage Under Brightness Control	$V_{REF\_PWM}$	$f_{PWM} = 10kHz$ , duty cycle = 3%	$+25^{\circ}C$	3.5	6	8.5	mV
$V_{REF}$ Filter 3dB Frequency	$f_{REF(3dB)}$		$+25^{\circ}C$		600		Hz
Voltage Feedback Input Bias Current	$I_{FB}$		Full		0.001	0.3	$\mu A$
SW Pin Leakage Current	$I_{SW}$		$+25^{\circ}C$		0.01	1	$\mu A$
Peak NMOS Current Limit	$I_{LIM}$		$+25^{\circ}C$		1.35		A
Oscillator Frequency	$f_s$		Full	0.90	1.10	1.4	MHz
Over-Voltage Threshold	$V_{OVP}$	Measured at VOUT pin	Full	35.5	38.0	40.5	V
Start-Up Time	$t_s$		$+25^{\circ}C$		800		$\mu s$
<b>CONTROL</b>							
Logic Low Threshold	$V_{IL}$		Full			0.35	V
Logic High Threshold	$V_{IH}$		Full	1.5			V
PWM Dimming Frequency Range	DFR		$+25^{\circ}C$	2		60	kHz
Minimum Shutdown Pulse Width Timing	$t_{OFF}$		$+25^{\circ}C$	3			ms
Junction Thermal Shutdown Threshold					150		$^{\circ}C$
Junction Thermal Shutdown Hysteresis					15		$^{\circ}C$

## NOTE:

1. The SGM3732 is guaranteed to meet performance specifications over the  $-40^{\circ}C$  to  $+85^{\circ}C$  operating temperature range by design, characterization and correlation with statistical process controls.

RECOMMENDED COMPONENTS OF TEST CIRCUITS

	COMPONENT		COMPONENT
INDUCTOR	22 $\mu$ H/CD75NP-220KC	CAPACITOR	10 $\mu$ F/C2012X7R1H106KT
	10 $\mu$ H/CD75NP-100KC		0.47 $\mu$ F/C2012X7R1H474KT
DIODE	MBR0540		

TYPICAL PERFORMANCE CHARACTERISTICS

T<sub>A</sub> = +25°C, L = 10 $\mu$ H, C<sub>IN</sub> = 10 $\mu$ F, C<sub>OUT</sub> = 0.47 $\mu$ F, unless otherwise noted.

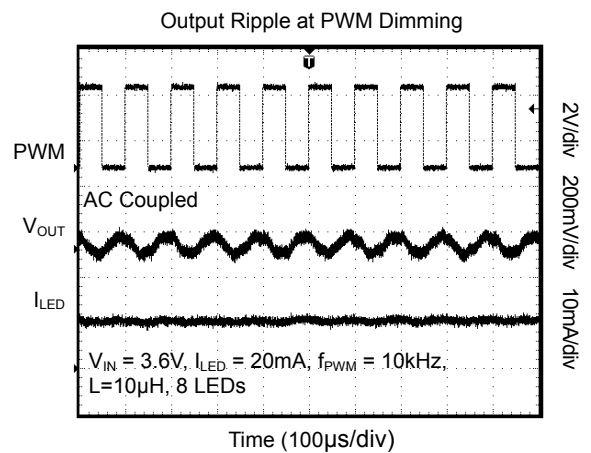
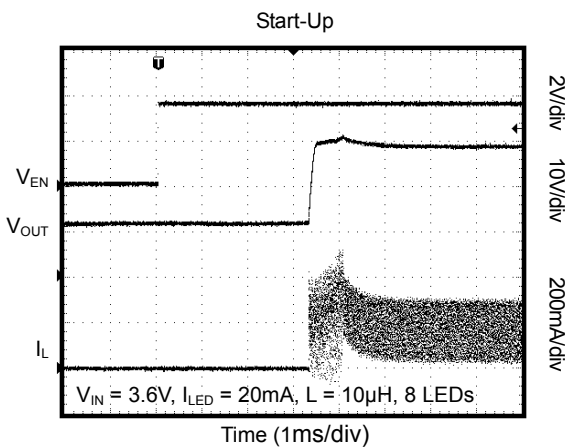
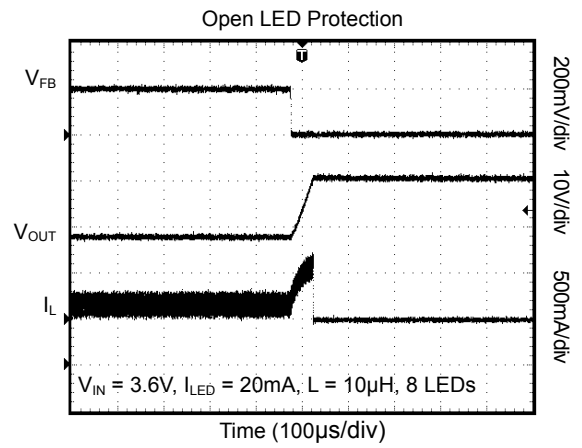
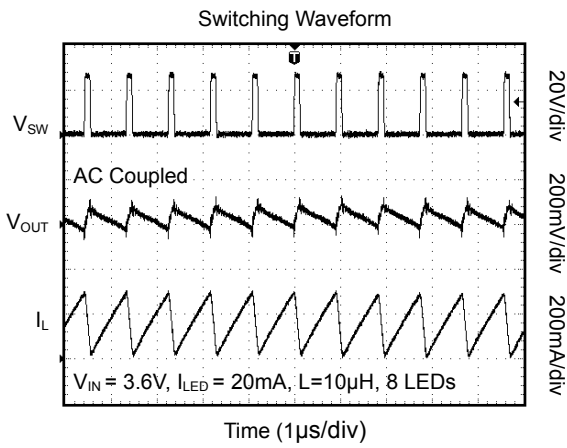

TYPICAL PERFORMANCE CHARACTERISTICS

T<sub>A</sub> = +25°C, L = 10µH, C<sub>IN</sub> = 10µF, C<sub>OUT</sub> = 0.47µF, unless otherwise noted.

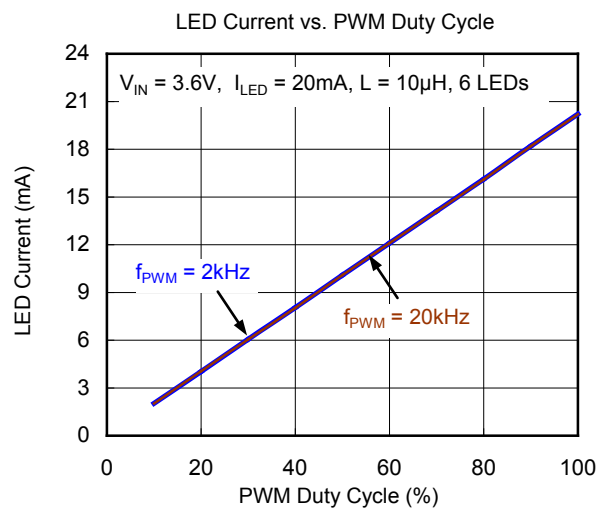
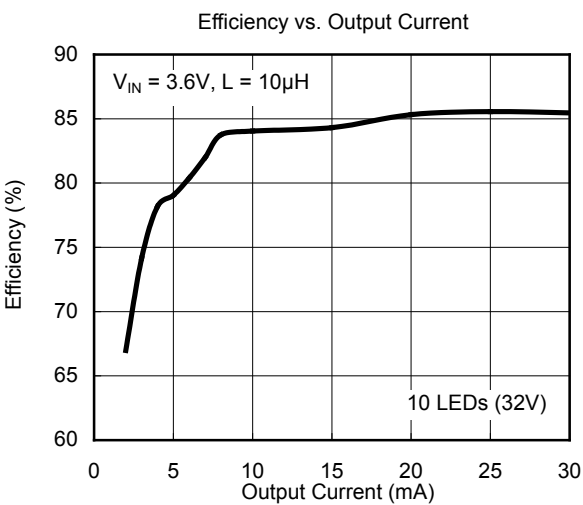
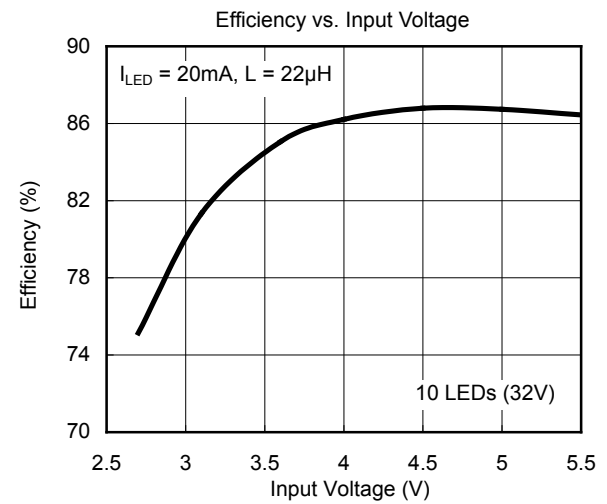
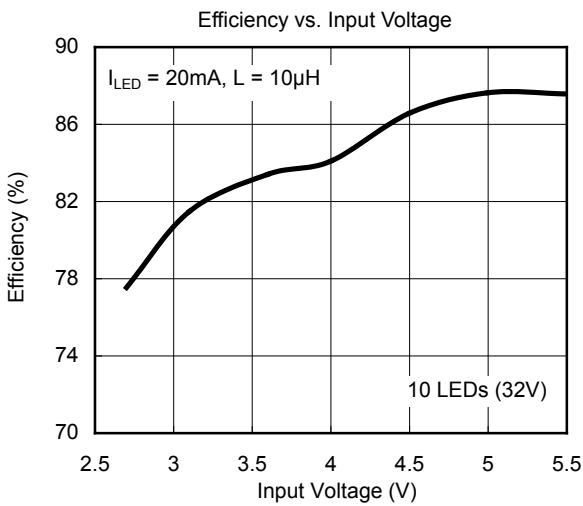
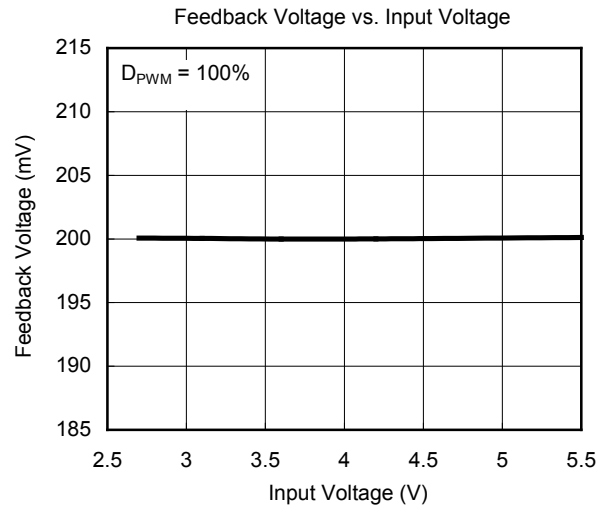
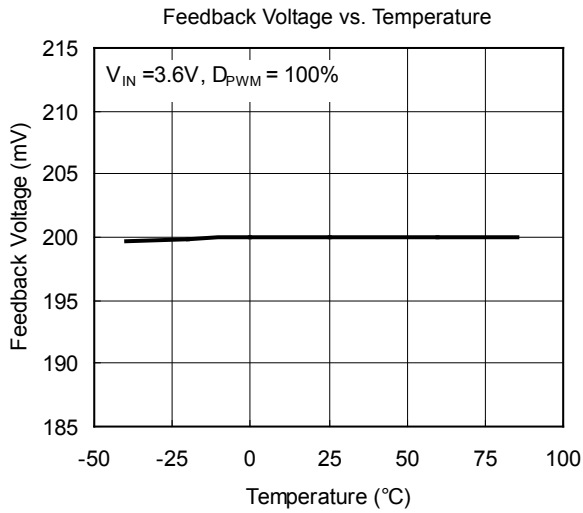

## FUNCTIONAL BLOCK DIAGRAM

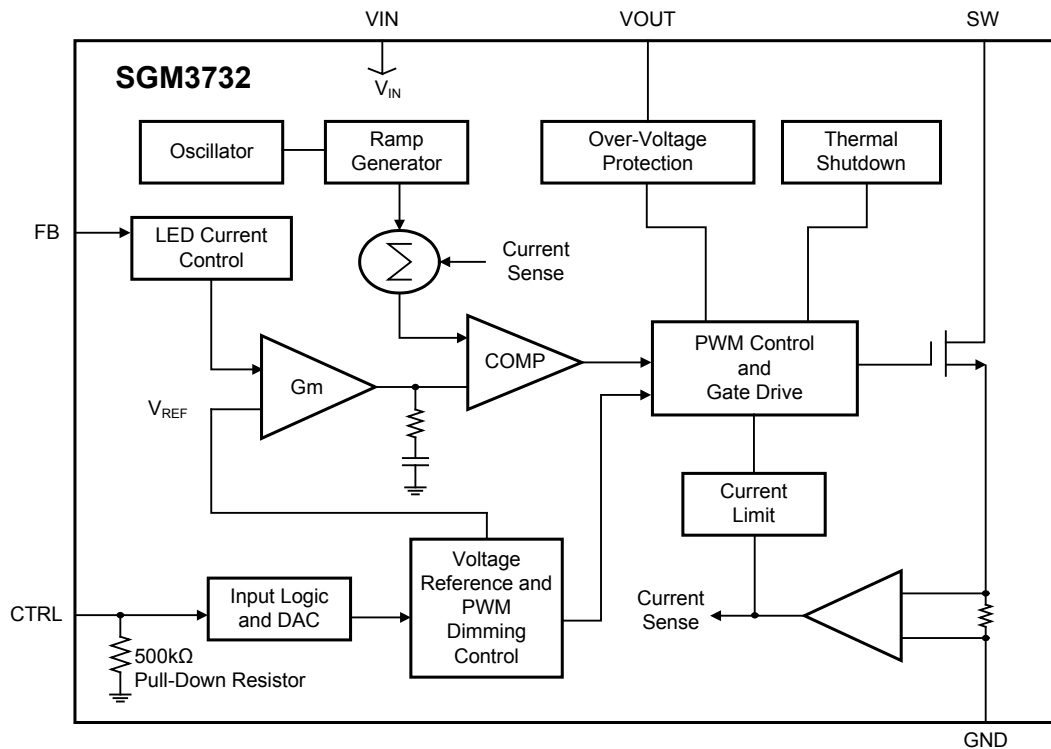

Figure 2. SGM3732 Block Diagram

## FUNCTIONAL DESCRIPTION

The SGM3732 uses a constant-frequency current-mode boost converter architecture to control the LED current by regulating the feedback voltage. Please refer to the FUNCTIONAL BLOCK DIAGRAM above for an explanation of SGM3732 operation. The beginning of each cycle turns on the Power MOSFET. A slope compensation ramp is added to the output of the current sense amplifier and the result is fed into the positive input of the comparator (COMP). When this voltage goes above the output voltage of the error amplifier (Gm), the Power MOSFET is turned off. The voltage at the output of the Gm block amplifies the difference between the reference voltage and the feedback voltage (FB), so that FB voltage can be regulated to the reference voltage.

The SGM3732 has built-in soft-start to limit the inrush current during start-up and to limit the amount of overshoot on the output. Protection features in the SGM3732 include over-voltage protection (OVP), cycle-by-cycle current limit protection and thermal shutdown. OVP protects in the event where an LED fails open, which forces the feedback voltage to zero. This causes the boost converter to operate in maximum duty cycle mode, ramping up the output voltage.

Switching will stop when the output reaches the OVP threshold. The OVP feature protects the IC from damaging itself by exceeding the voltage rating on SW/VOUT pins.

For the brightness dimming control of the SGM3732, the IC provides typically 200mV feedback voltage when the CTRL pin is pulled constantly high. However, CTRL pin allows a PWM signal to reduce this regulation voltage by changing the PWM duty cycle to achieve LED brightness dimming control. An internal low pass filter (600Hz) is used to filter the pulse signal. The relationship between the duty cycle and FB voltage can be calculated as following equation.

$$V_{FB} = \text{Duty} \times 200\text{mV}$$

Where:

Duty = duty cycle of the PWM signal  
200mV = internal reference voltage

The PWM frequency is in the range from 2kHz to 60kHz, and the recommended minimum PWM duty cycle is 3% for no blind dimming.

**APPLICATION INFORMATION**

**Inductor Selection**

A 6.8µH to 22µH inductor is recommended for 10/8/6 series LED applications and 10S4P LED applications. If high efficiency is a critical requirement, a low DCR inductor should be selected. The inductor’s saturation current rating should also exceed the peak input current, especially for high load current application (like 10S4P).

**Capacitor Selection**

Small size ceramic capacitors are ideal for SGM3732 application. An input capacitor in the range of 1µF to 22µF and a 0.47µF output capacitor are suggested for 10/8/6 series LED applications. For higher output current applications like 10S4P, larger value output capacitors like 2.2µF are recommended to minimize output ripple.

**Diode Selection**

The current rating of the Schottky diode should exceed the peak current of the boost converter. The voltage rating should also exceed the target output voltage.

**LED Maximum Current Setting**

LED maximum current setting,  $I_{MAX}$ , is determined by the feedback resistor ( $R_{SET}$  in Figure 3). The feedback voltage is internally set at 200mV when the PWM dimming duty cycle = 100%. The LED current is programmed according to the formula  $I_{MAX} = 200mV/R_{SET}$ . For accurate LED current settings, precision 1% resistors are recommended. The formula and table for  $R_{SET}$  selection are shown below.

$$R_{SET} = 200mV/I_{MAX}$$

**Table 1. Current Setting Resistor**

$R_{SET}$ (Ω)	$I_{MAX}$ Current (mA)
200	1
40.2	5
20.0	10
13.3	15
10.0	20
6.65	30
2.00	100

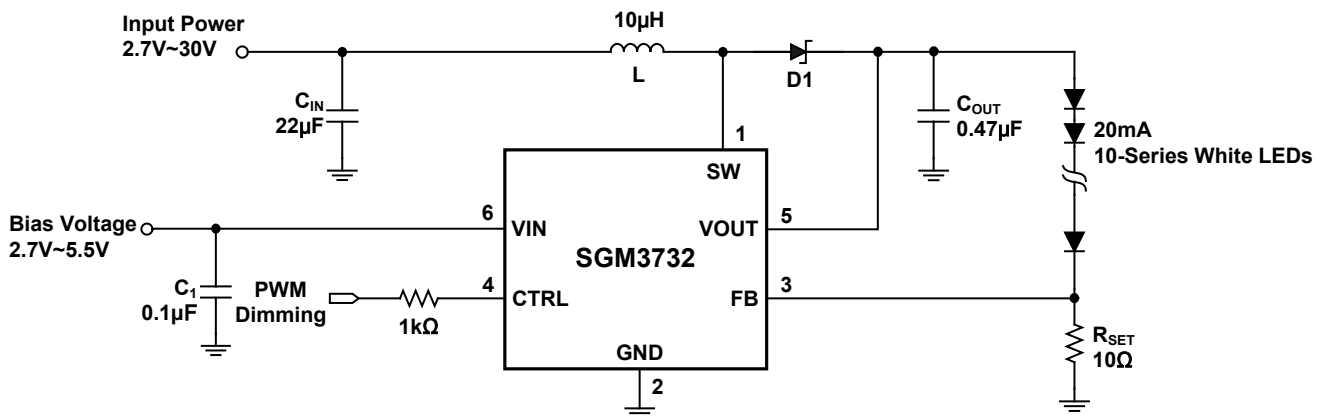

Figure 3. Application Circuit for 10 LEDs in Series with 20mA Current (VIN can be tied to input power rail if less than 5.5V)



APPLICATION INFORMATION

PCB Layout Considerations

As for all switching power supplies, especially those high frequency and high current ones, layout is an important design step. If layout is not carefully done, the regulator could suffer from instability as well as noise problems. To reduce switching losses, the SW pin rise and fall times are made as short as possible. To prevent radiation of high frequency resonance problems, proper layout of the high frequency switching path is essential. Minimize the length and area of all traces connected to the SW pin and always use a ground plane under the switching regulator to minimize inter-plane coupling. The loop including the PWM

switch, Schottky diode, and output capacitor, contains high current rising and falling in nanosecond and should be kept as short as possible. Both B1 and B2 (in Figure 4) magnetic Beads are recommended to be used to reduce EMI.

The input and the output bypass capacitors should be placed as close to the IC as possible. Minimize trace lengths between the IC and the inductor, the diode and the output capacitor; keep these traces short, direct, and wide. A recommended PCB layout is shown in Figure 5.

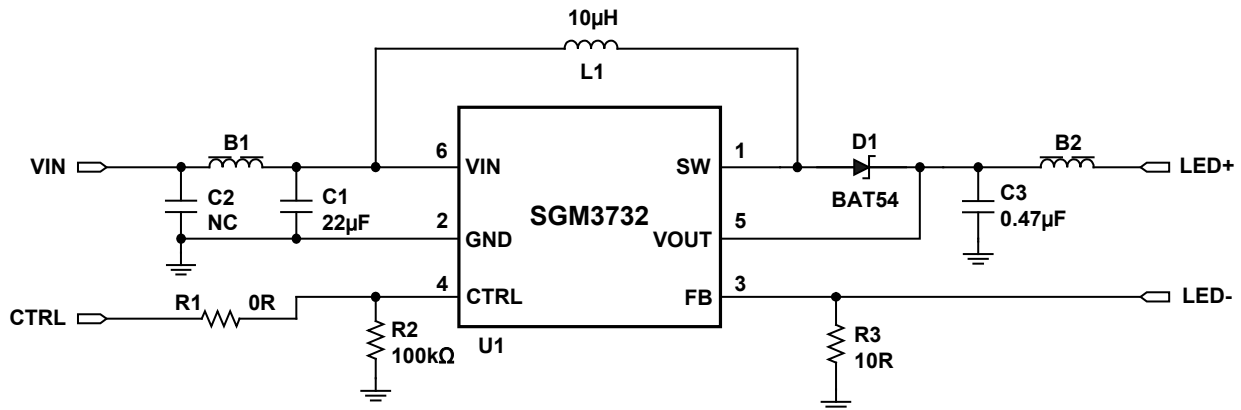

Figure 4. Schematic

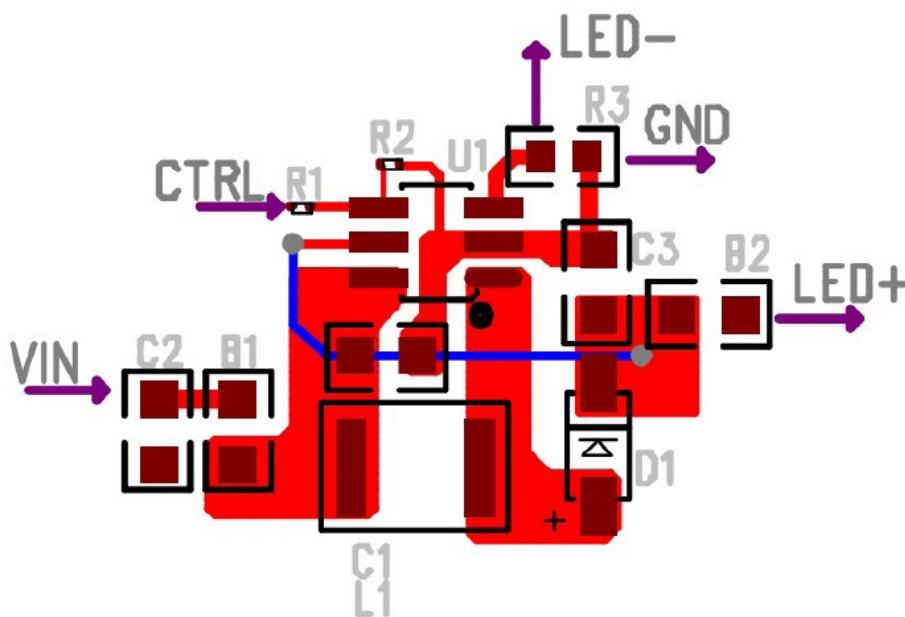
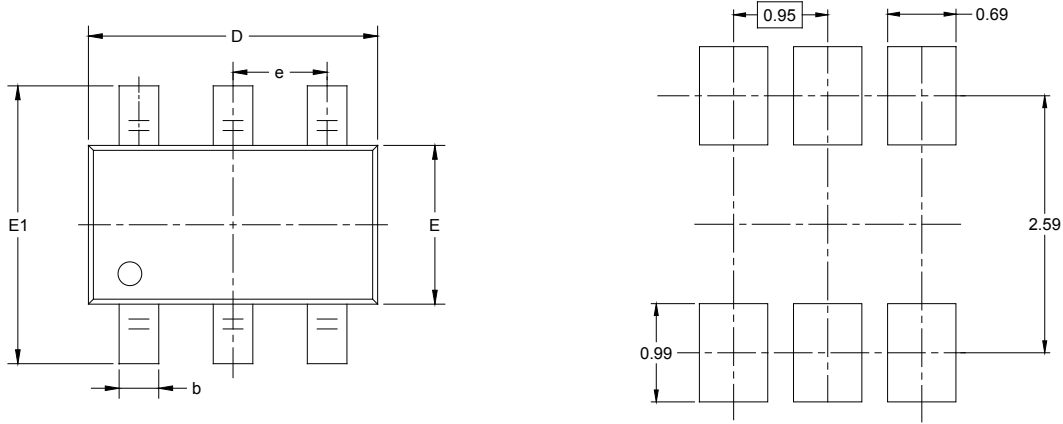

Figure 5. Recommended PCB Layout

PACKAGE OUTLINE DIMENSIONS

TSOT-23-6



RECOMMENDED LAND PATTERN (Unit: mm)

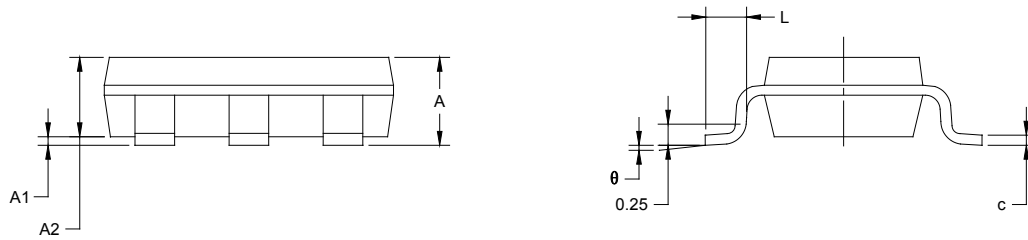

Symbol	Dimensions In Millimeters		Dimensions In Inches	
	MIN	MAX	MIN	MAX
A		1.000		0.043
A1	0.000	0.100	0.000	0.004
A2	0.700	0.900	0.028	0.039
b	0.300	0.500	0.012	0.020
c	0.080	0.200	0.003	0.008
D	2.850	2.950	0.112	0.116
E	1.550	1.650	0.061	0.065
E1	2.650	2.950	0.104	0.116
e	0.950 BSC		0.037 BSC	
L	0.300	0.600	0.012	0.024
θ	0°	8°	0°	8°

TAPE AND REEL INFORMATION

REEL DIMENSIONS

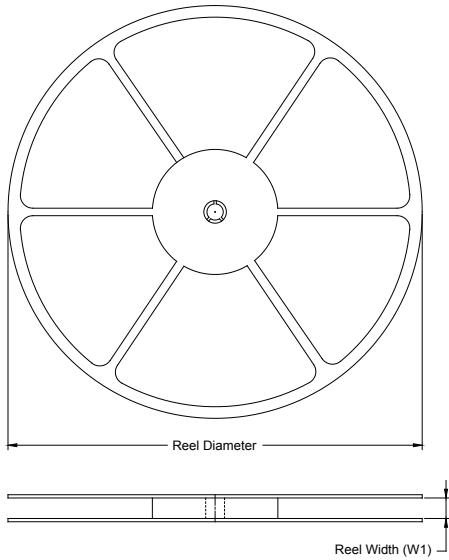

TAPE DIMENSIONS

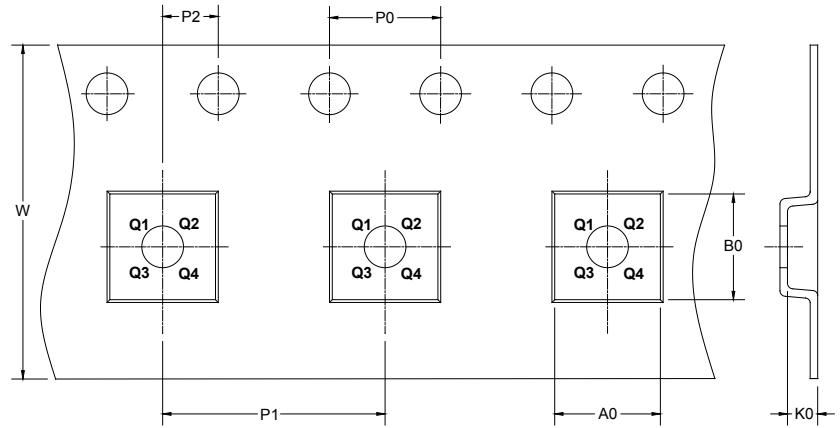

➔ DIRECTION OF FEED

NOTE: The picture is only for reference. Please make the object as the standard.

KEY PARAMETER LIST OF TAPE AND REEL

Package Type	Reel Diameter	Reel Width W1 (mm)	A0 (mm)	B0 (mm)	K0 (mm)	P0 (mm)	P1 (mm)	P2 (mm)	W (mm)	Pin1 Quadrant
TSOT-23-6	7"	9.5	3.2	3.1	1.1	4.0	4.0	2.0	8.0	Q3

000001

## CARTON BOX DIMENSIONS

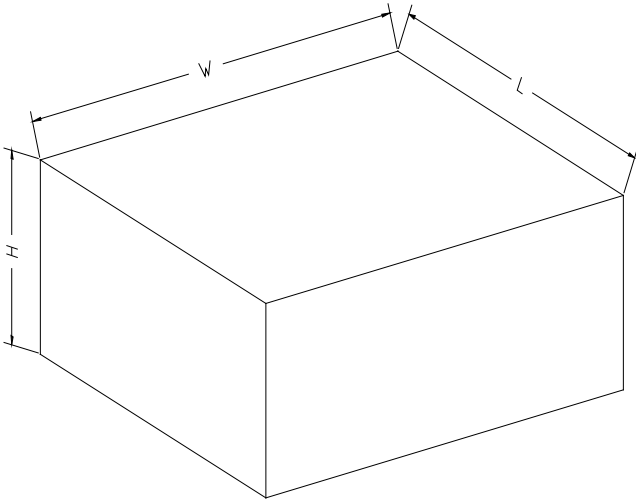

NOTE: The picture is only for reference. Please make the object as the standard.

## KEY PARAMETER LIST OF CARTON BOX

Reel Type	Length (mm)	Width (mm)	Height (mm)	Pizza/Carton
7" (Option)	368	227	224	8
7"	442	410	224	18

DD0002