

H.ELE.

Specifications for Approval



| | |
|----------------------|---|
| CUSTOMER | 宇 珈 |
| PRODUCT TYPE | Crystal Oscillator HSO321S |
| NOMINAL FREQUENCY | 12.000000MHz |
| H.ELE. SAMPLE O/N | EOS-I50057-12 |
| H.ELE. P/N | SSW012000I3CHE-T |
| RELEASE DATE | 2018/05/07 |
| VERSION | 00 |
| MSL | Level 1 |
| GREEN PRODUCT | <input checked="" type="checkbox"/> Pb free <input checked="" type="checkbox"/> RoHS Compliant <input checked="" type="checkbox"/> HF-Halogen free <input checked="" type="checkbox"/> REACH Compliant |
| CUSTOMER P/N | |
| APPLICATION & MODEL | |
| APPROVED BY CUSTOMER | |

(DATE)

| | | | |
|----------------------------------|------------------------------|--------------------------------|--|
| Harmony Electronics Corp. | | | |
| <u>F. S. TSAI</u> (APPROVE) | <u>C. H. WENG</u> (CHECK) | <u>U. F. CHEN</u> (PREPARE) | Country of Origin: Taiwan Factory Thailand Factory China Factory |

HARMONY ELECTRONICS CORPRATION

KAOSIUNG

TAIPEI

THAILAND

SHENZHEN

TEL: 886-2-26588883

Email: contactus@hele.com.tw



Contents

| ITEM | PAGE |
|-------------------------------------|------|
| 1. CRYSTAL OSCILLATOR SPECIFICATION | 3-4 |
| 2. DIMENSIONS | 4 |
| 3. MARKING | 5 |
| 4. INSIDE STRUCTURE | 5 |
| 5. HANDLING SUGGESTIONS | 5-6 |
| 6. EMBOSS CARRIER TAPE&REEL | 7-8 |
| 7. PACKAGE | 8 |
| 8. MECHANICAL PERFORMANCE | 9 |
| 9. ENVIRONMENTAL PERFORMANCE | 9 |
| 10. APPENDIX | |

HARMONY ELECTRONICS CORPRATION

KAOHSIUNG

TAIPEI

THAILAND

SHENZHEN

TEL: 886-2-26588883

Email: contactus@hele.com.tw



1. CRYSTAL OSCILLATOR SPECIFICATION

■ Electrical Specifications

| Items | Symbol | Electrical Spec. | | | Unit | Condition |
|---|---|------------------|------|---------|----------|--------------------|
| | | Min | Type | Max | | |
| 1. Output Frequency | (FL) | 12.000000 | | | MHz | |
| Frequency Stability | $\Delta f/F$ | -50 | - | +50 | ppm | @3.3±0.3V/-40~85°C |
| Operating temp. range | Topr | -40 | 25 | +85 | °C | |
| Supply voltage | Vdd | 3.0 | 3.3 | 3.6 | V | |
| Pin #1 options | YES | | | | | |
| Output load | C-MOS CL =15pF (Idd1, Idd2 test at No Load) | | | | | |
| Current consumption 1 (#1 pin: open or "H") | Idd1 | - | - | 7 | mA | @3.3V/ 25±3°C |
| Current consumption 2 (#1 pin: "L" level) | Idd2 | - | - | 0.01 | mA | |
| Low level output voltage | Vol | - | - | 0.1xVdd | V | |
| High level output voltage | Voh | 0.9xVdd | - | - | V | |
| Symmetry | Duty | 40 | 50 | 60 | % | |
| Rise & Fall time | Tr & Tf | - | - | 10 | ns | |
| Low level input current | Iil | - | - | 10 | uA | |
| High Level input current | Iih | - | - | 10 | uA | |
| Low level input voltage | Vil | - | - | Vddx0.3 | V | |
| High level input voltage | Vih | Vddx0.7 | - | - | V | |
| Output disable time | Tplz | - | - | 150 | nsec | |
| Output enable time | Tpzl | - | - | 10 | msec | |
| Aging | - | -3 | - | 3 | ppm/year | |
| Start-up time | - | - | - | 10 | ms | |
| Jitter, Phase | RMS(1-σ) | - | - | 1 | ps | |

Note:

■ Absolute Maximum Ratings

| Item | Symbol | Value | Unit |
|-------------------------|--------|----------------|-------|
| Vdd terminal voltage | Vdd | -0.5 ~ 4.0 | V |
| Input terminal voltage | Vcont | -0.5 ~ Vdd+0.5 | V |
| Output terminal voltage | Vout | -0.5 ~ Vdd+0.5 | V |
| Output terminal current | Iout | 15 | mA |
| Storage temp. range | Tstr | -55 ~ 125 | deg.C |

HARMONY ELECTRONICS CORPRATION

KAOSIUNG

TAIPEI

THAILAND

SHENZHEN

TEL: 886-2-26588883

Email: contactus@hele.com.tw



■ TEST Circuit

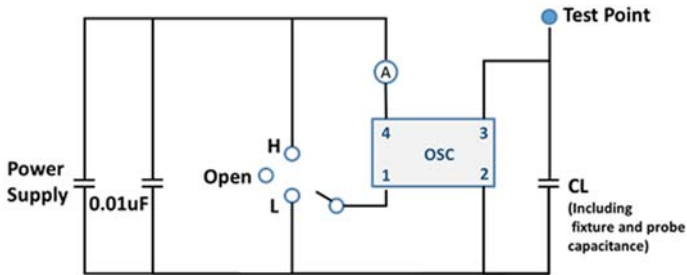

CL = Include jig & probe capacitance
(Refer to 4)

| | |
|--------|-----------------|
| Switch | Out term. |
| H | Oscillation out |
| Open | Oscillation out |
| L | High Z |

■ Output Wave Form

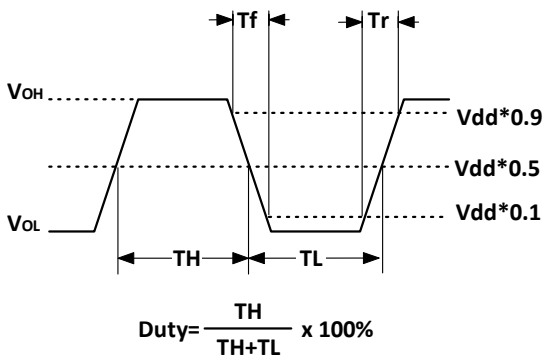

■ Input and Output Condition

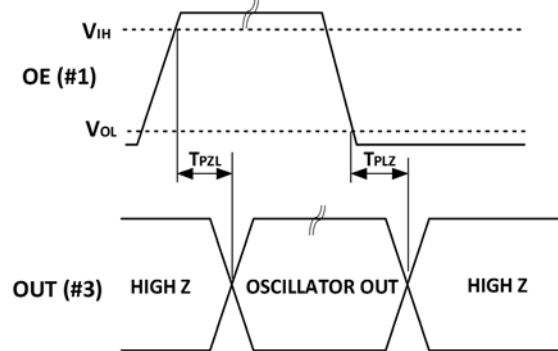

2. DIMENSION

TOP VIEW

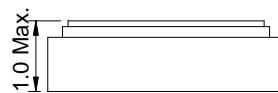
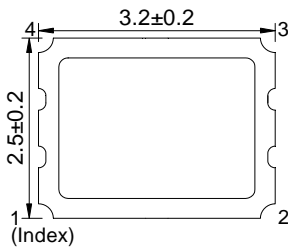

BOTTOM VIEW

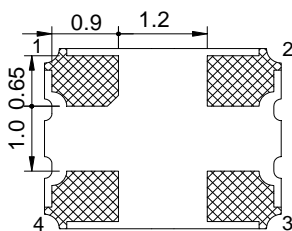

Tolerance: ±0.1
Unit: mm

TOP VIEW
Land Pattern Layout

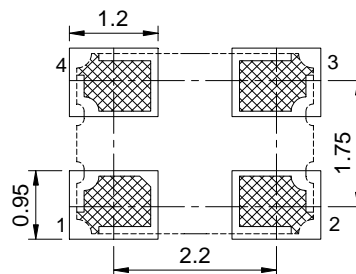

| Pin | Connections |
|-----|-------------------|
| #1 | OE(Output Enable) |
| #2 | GND |
| #3 | Output |
| #4 | Vdd |

* Note: The Index mark was defined by the BASE suppliers.

HARMONY ELECTRONICS CORPRATION

KAOSIUNG

TAIPEI

THAILAND

SHENZHEN

TEL: 886-2-26588883

Email: contactus@hele.com.tw



3. MARKING

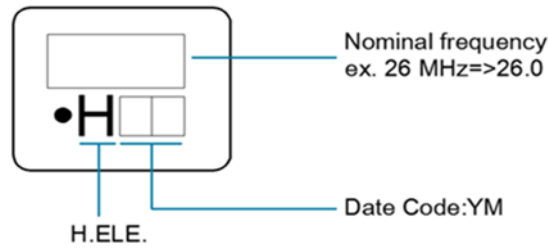

Note:

1. Laser marking.
2. Date Code:

| | | | | | | | | | | |
|---------|------|------|------|------|------|------|------|------|------|------|
| Y= Year | 2010 | 2011 | 2012 | 2013 | 2014 | 2015 | 2016 | 2017 | 2018 | 2019 |
| | 2020 | 2021 | 2022 | 2023 | 2024 | 2025 | 2026 | 2027 | 2028 | 2029 |
| Code | 0 | 1 | 2 | 3 | 4 | 5 | 6 | 7 | 8 | 9 |

| | | | | | | | | | | | | |
|----------|------|------|------|------|------|------|------|------|------|------|------|------|
| M= Month | Jan. | Feb. | Mar. | Apr. | May. | Jun. | Jul. | Aug. | Sep. | Oct. | Nov. | Dec. |
| Code | A | B | C | D | E | F | G | H | J | K | L | M |

4. INSIDE STRUCTURE

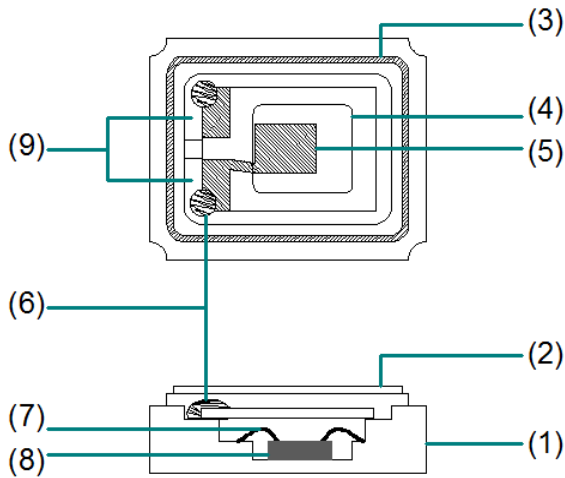

Reference drawing

| No. | Component | Material | Note |
|-----|---------------------|---------------|--|
| 1 | Base-Ceramic | Ceramic | Al ₂ O ₃ |
| 2 | Lid | Fe- Ni -Co | Fe- Ni -Co |
| 3 | Kovar | Fe-Ni-Co | Fe-Ni-Co |
| 4 | Crystal Blank | Metal | SiO ₂ Rectangular At-Cut |
| 5 | Electrode | Metal | - |
| 6 | Connective Adhesive | Silver Powder | Ag |
| 7 | Bonding Wire | Metal | Au |
| 8 | IC | Silicon | Si, Al |
| 9 | Pad | Metal | W Ni-Plating Au-Plating |

※The use prohibition chemistry substance of Table 1 of DHE-0204-1 (HE-QA-24) is not included in this item.

5. HANDLING SUGGESTION

■ Reflow Condition

Please stay with our proposed reflow condition and do soldering within 2 times.

| | | | |
|-----|--------------|--------------|--------------|
| (1) | Preheat | 160~180deg.C | 120 sec. |
| (2) | Primary heat | >=220 deg.C | 60~120 sec. |
| (3) | Peak | 260 deg.C | 10 sec. Max. |

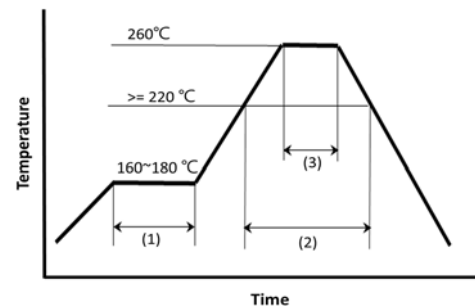

HARMONY ELECTRONICS CORPRATION

KAOHSIUNG

TAIPEI

THAILAND

SHENZHEN

TEL: 886-2-26588883

Email: contactus@hele.com.tw



■ Manual Solder iron (Example)

Bit temp.: 350°C max., Time: 3sec max. ,
Each terminal Each only should be soldered once.

■ Mounting Conditions

Our products are suitable for most automated SMT processes. However, we strongly advise all our customers to conduct SMT sampling prior to mass production in order to make sure production processes will not affect the properties and specifications of our product. Seal welding and mounting procedures involving the use of ultra-sonic processes are not recommended and will affect and/or damage the internal properties of our product. Excessive shock during the mounting process will also affect the product and we strongly recommend setting SMT conditions to minimize such conditions. If a possibility of the PCB being warped exists we strongly advise to ensure the degree of warping will not affect the product. Please also ensure the operating characteristics and or soldering conditions are all within the specifications of use for our product.

Ultimately the worst case scenario of all the above will lead to cases of non-oscillation but other negative effects are also likely should our products be used in an inappropriate way. Please note such cases of misuse and its related quality issues are not included in our product warranty.

■ Cleansing Conditions

General cleaning solutions may be used to clean our products but we always recommend testing to be performed prior to mass production processes. Ultrasonic cleaning procedures are not recommended and we strongly advise other forms of cleansing to be evaluated first. Unsuitable cleansing may lead to a number of negative effects such as damage to the product surface, discoloration of the product, corrosion of the package, package contamination, illegible marking, etc. Please note cases of unadvised treatment and its related quality issues are not included in our product warranty.

■ Storage Conditions

Please ensure our products are preserved appropriately in their original packaging. Irregular environmental instances of moisture will affect our product's stability and may cause problems such as frequency instability, soldering ability and conditions, package defects, and other problems. It is essential to keep our products in a clean dust-free environment out of direct sunlight.

Our products' storage conditions should at least meet the following condition:
Environmental Temperature: + 125 degrees Celsius Maximum
Relative Humidity: 80% Maximum

Please note storage instances which do not conform to our guidelines and the related quality issues produced as an outcome are not included in our product warranty.

HARMONY ELECTRONICS CORPRATION

KAOHSIUNG

TAIPEI

THAILAND

SHENZHEN

TEL: 886-2-26588883

Email: contactus@hele.com.tw



6. EMOSS CARRIER TAPE AND REEL

Carrier Tape

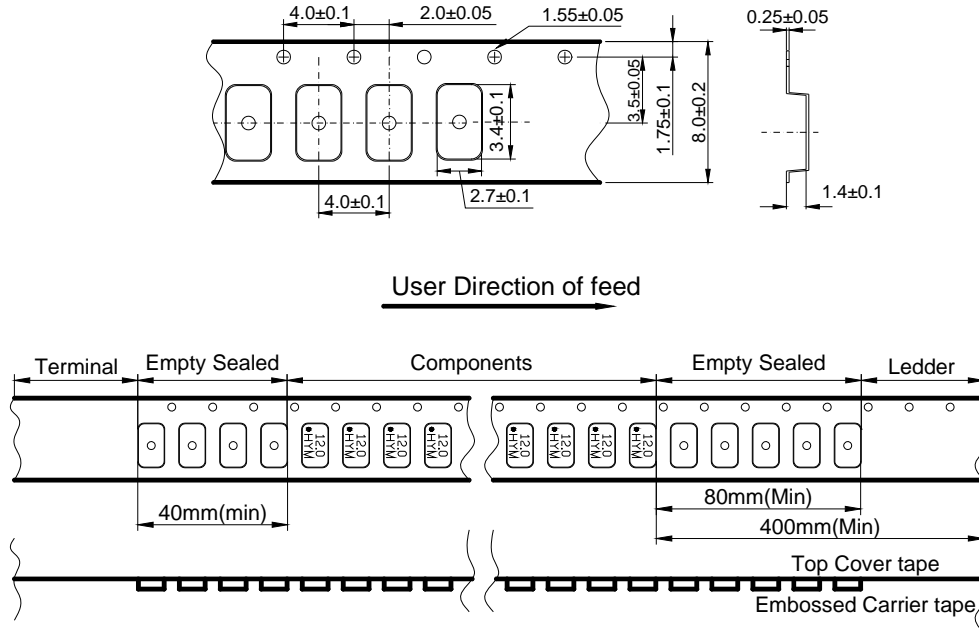

Reel

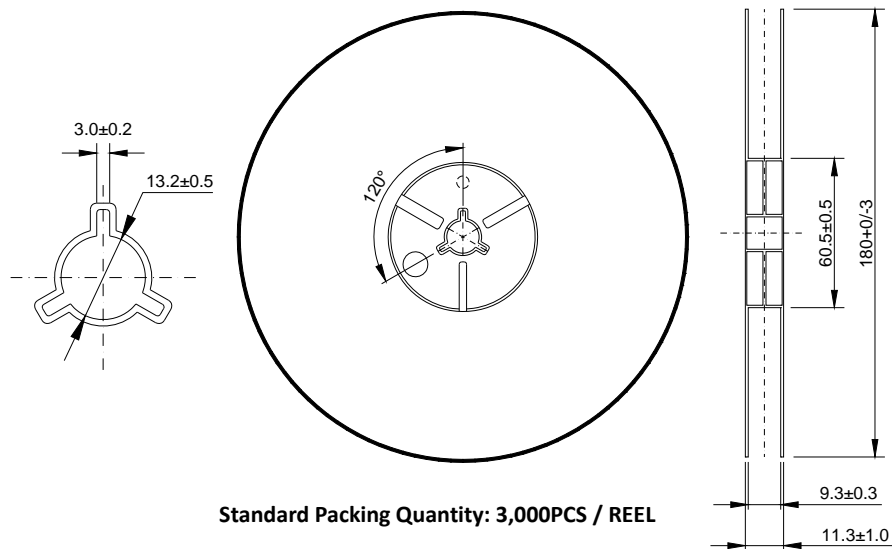

Material of The Tape

| Tape | Material |
|--------------|---------------|
| Carrier tape | PS Conductive |
| Top tape | PET |

Joint of tape

The carrier-tape and top cover-tape should not be jointed.

HARMONY ELECTRONICS CORPRATION

KAOSIUNG

TAIPEI

THAILAND

SHENZHEN

TEL: 886-2-26588883

Email: contactus@hele.com.tw



■ **Release strength of cover tape**

The force should be controlled between 0.1N to 0.7N under following condition.

Pulling direction: 165° to 180°

Speed: 300mm/min.

Otherwise unless specified.

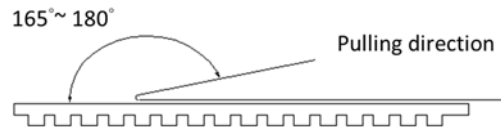

Other standards shall be based on JIS C 0806-1990.

7. PACKAGE

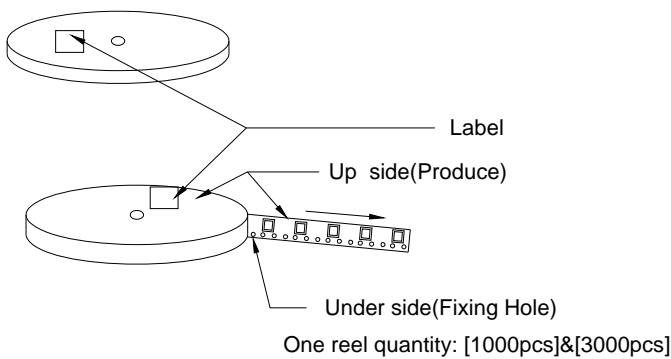

Label Contents

TYPE:
SPEC. No.:
Parts No.:
Lot No.:

FREQ.: MHz
Q'TY: PCS

HARMONY ELECTRONICS CORP.

Q.C. PASS H10

HSF

The label will be stickled on all reels.

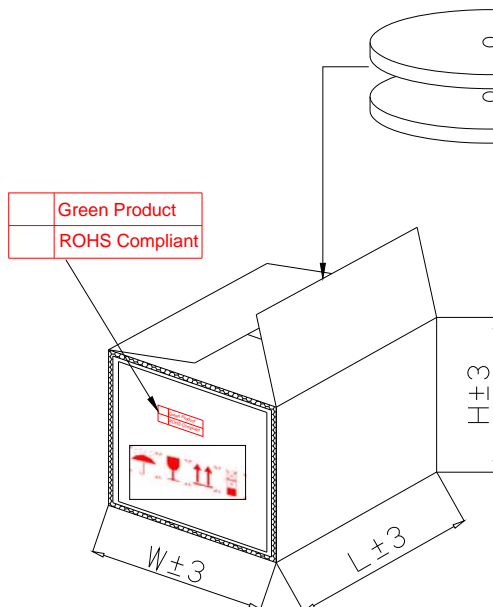
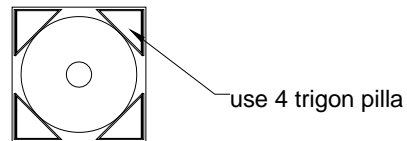

| Carton Type | A | B | C | D |
|--------------|---------|-----------------|--------------------|-------|
| Produce Type | 840/751 | 630/531/ 421 | 321/221 211/111 | OTHER |
| Reel | 15 | 15 | 15 | 1~7 |
| L±3 | 200 | 200 | 200 | 195 |
| W±3 | 200 | 200 | 200 | 195 |
| H±3 | 230/260 | 230 | 230 | 150 |

- ①Top and bottom with 2.3cm thickness foam-rubber cushion for protection.
- ②Carton's Q'TY:1~15 pcs.
- ③Carton Type=A,B,C use 4 trigon pillar to fasten the Reel.
- ④Need to add 3 pages dry agent in each outer box.

HARMONY ELECTRONICS CORPRATION

KAOHSIUNG

TAIPEI

THAILAND

SHENZHEN

TEL: 886-2-26588883

Email: contactus@hele.com.tw



8. MECHANICAL PERFORMANCE

| Item | | Test Methods | Specifications Code |
|------|----------------|---|---------------------|
| 1 | Shock | Dropping from 50 cm height 3 times on 30mm hard wooden board. Refer to: JIS C 60068-2-32 | A |
| 2 | Vibration | Frequency 10-55Hz, Sine Wave full amplitude of 0.8mm to X, Y and Z 3 axes, Duration of 2 hours to each axis. Refer to: JIS C 60068-2-6 | A |
| 3 | Leakage Test | Leak Rate 1.0×10^{-9} Pa·m ³ /sec. Max. Measured by Helium leak detector. | --- |
| 4 | Solder ability | After applying ROSIN Flux, dipping in solder bath at 245deg.C +/- 5deg.C for 3+/-0.5 sec. Refer to: JIS C 60068-2-20 | B |

9. ENVIRONMENT PERFORMANCE

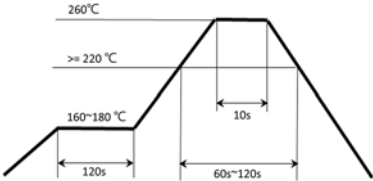
| Item | | Test Methods | Specifications Code |
|------|------------------------------|---|---------------------|
| 1 | Resistance of Soldering Heat | Performing as the following reflow:  | A |
| 2 | Humidity | Temperature 60°C +/- 2°C, RH 90~95%, Duration of 240 hours. Back to the room temperature first, then check the component after 1~2 hours. Refer to: JIS C 60068-2-3 | A |
| 3 | Storage in Low Temperature | -55deg.C +/- 2deg.C, Duration of 240 hours. Back to the room temperature first, then check the component after 1~2 hours. Refer to: JIS C 60068-2-1 | A |
| 4 | Storage in High Temperature | +125deg.C +/- 2deg.C, Duration of 240 hours. Back to the room temperature first, then check the component after 1~2 hours. Refer to: JIS C 60068-2-2 | A |
| 5 | Temperature cycles | -55deg.C +/- 2deg.C (30min) ↔ +125deg.C +/- 2deg.C (30min) 25 cycles. And Temperature Increasing/reducing time < 3mins. Back to the room temperature first, then check the component after 1~2 hours. Refer to: JIS C 0025 | A |

| Specifications code | Specifications |
|---------------------|---|
| A | Frequency variation shall be within +/- 5ppm |
| B | More than 90% of lead shall be covered by new solder. |

HARMONY ELECTRONICS CORPRATION

KAOHSIUNG

TAIPEI

THAILAND

SHENZHEN

TEL: 886-2-26588883

Email: contactus@hele.com.tw

FACTORY LOCATION

HEAD OFFICE/TAIWAN FACTORY

NO.39, HUADONG RD., DALIAO DIST., DAFA INDUSTRIAL PARK, KAOHSIUNG CITY 831, TAIWAN.

CHINA FACTORY

JU YUAN INDUSTRIAL PARK, QIAO TANG ROAD, TANG WEI COMMUNITY, FUYONG, BAOAN DISTRICT, SHEN ZHEN CITY, CHINA (Post Code:518103).

THAILAND FACTORY

66MOO 5, KAONGU-BEOKPRAI RD., T.BEOKPRAI, A. BANPONG, RATCHABURI PROVINCE 70110, THAILAND.

SERVICE CENTER

TAIPEI OFFICE

2F., NO.409, SEC.2, TIDING BLVD., NEIHU DISTRICT, TAIPEI CITY 114, TAIWAN
TEL: 886-2-26588883
FAX: 886-2-26588683

CONTACT INFORMATION

E-MAIL: contactus@hele.com.tw



加高電子股份有限公司
HARMONY ELECTRONICS CORP.

