

**Technical Data Sheet****Side View LEDs (Height 0.8mm)****99-213/G6C-BQ1R2B/2C****Features**

- Side view LED.
- Lead frame package with individual 2 pins.
- Wide viewing angle.
- Soldering methods: IR reflow soldering.
- Pb-free.
- The product itself will remain within RoHS compliant version.

**Descriptions**

- Due to the package design, 99-213 has wide viewing angle, low power consumption and white LEDs are devices which are materialized by combining Blue LEDs and special phosphors. This feature makes the LED ideal for light guide application.

**Applications**

- LCD Back Light.
- Mobile phones .
- Indicators.
- Illuminations.
- Switch Lights.

**Device Selection Guide**

Chip	Emitted Color	Resin Color
Material		
AlGaInP	Brilliant Yellow Green	Water Clear

**Technical Data Sheet**

**Side View LEDs (Height 0.8mm)**

**99-213/G6C-BQ1R2B/2C**

**Package Outline Dimensions**

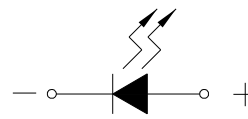
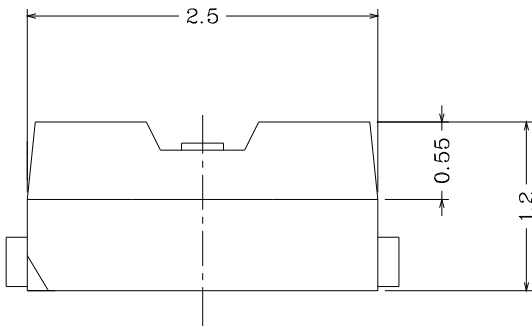

Polarity

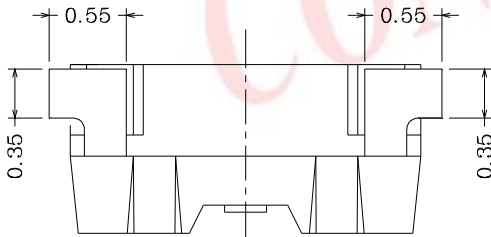
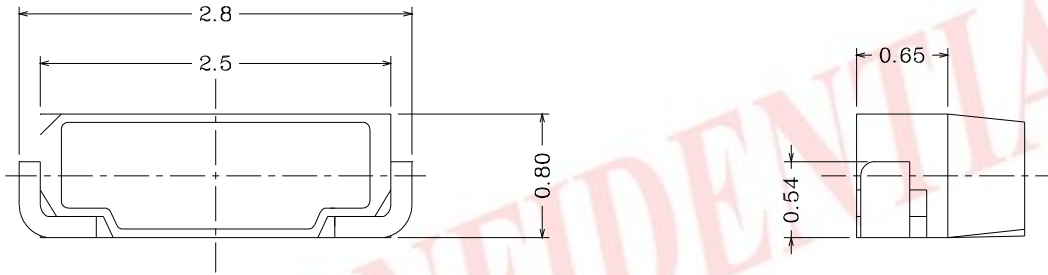

Recommended soldering pad design

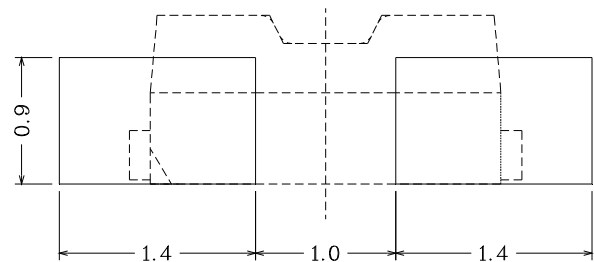

**Notes:** Tolerances Unless Dimension  $\pm 0.1\text{mm}$ , Unit = mm

**Technical Data Sheet****Side View LEDs (Height 0.8mm)****99-213/G6C-BQ1R2B/2C****Absolute Maximum Ratings (Ta=25 )**

Parameter	Symbol	Rating	Unit
Reverse Voltage	V <sub>R</sub>	5	V
Forward Current	I <sub>F</sub>	25	mA
Peak Forward Current (Duty 1/10 @ 1KHz)	I <sub>FP</sub>	60	mA
Power Dissipation	P <sub>d</sub>	60	mW
Electrostatic Discharge(HBM)	ESD	2000	V
Operating Temperature	T <sub>opr</sub>	-40 ~ +85	
Storage Temperature	T <sub>stg</sub>	-40~ +90	
Soldering Temperature	T <sub>sol</sub>	Reflow Soldering : 260 Hand Soldering : 350	for 10 sec. for 3 sec.

**Electro-Optical Characteristics (Ta=25 )**

Parameter	Symbol	Min.	Typ.	Max.	Unit	Condition
Luminous Intensity	I <sub>v</sub>	72.0	-----	180.0	mcd	I <sub>F</sub> =20mA
Viewing Angle	2θ <sub>1/2</sub>	-----	110	-----	deg	
Peak Wavelength	λ <sub>p</sub>	-----	575	-----	nm	
Dominant Wavelength	λ <sub>d</sub>	567.5	-----	575.5	nm	
Spectrum Radiation Bandwidth	λ	-----	20	-----	nm	
Forward Voltage	V <sub>F</sub>	1.75	---	2.35	V	
Reverse Current	I <sub>R</sub>	-----	-----	10	μA	V <sub>R</sub> =5V

**Notes:**

1. Tolerance of Luminous Intensity : ±11%
2. Tolerance of Dominant Wavelength : ±1nm
3. Tolerance of Forward Voltage : ±0.1V

**Technical Data Sheet****Side View LEDs (Height 0.8mm)****99-213/G6C-BQ1R2B/2C****Bin Range of Luminous Intensity**

Bin Code	Min.	Max.	Unit	Conduction
Q1	72	90	mcd	I <sub>F</sub> =20mA
Q2	90	112		
R1	112	140		
R2	140	180		

**Bin Range of Dominant Wavelength**

Group	Bin	Min.	Max.	Unit	Condition
B	C15	567.5	569.5	nm	I <sub>F</sub> =20mA
	C16	569.5	571.5		
	C17	571.5	573.5		
	C18	573.5	575.5		

**Bin Range of Forward Voltage**

Group	Bin	Min.	Max.	Unit	Condition
B	0	1.75	1.95	V	I <sub>F</sub> =20mA
	1	1.95	2.15		
	2	2.15	2.35		

**Notes:**

1. Tolerance of Luminous Intensity :  $\pm 11\%$
2. Tolerance of Dominant Wavelength :  $\pm 1\text{nm}$
3. Tolerance of Forward Voltage :  $\pm 0.1\text{V}$

**Technical Data Sheet**

**Side View LEDs (Height 0.8mm)**

**99-213/G6C-BQ1R2B/2C**

**Typical Electro-Optical Characteristics curves**

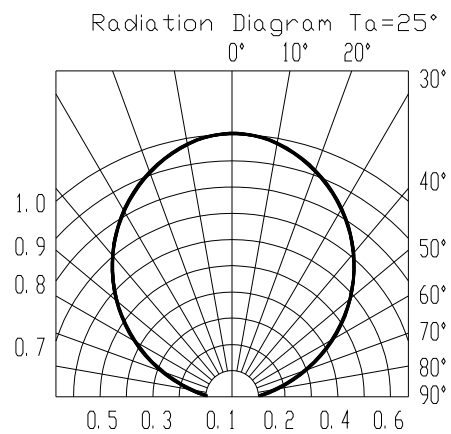
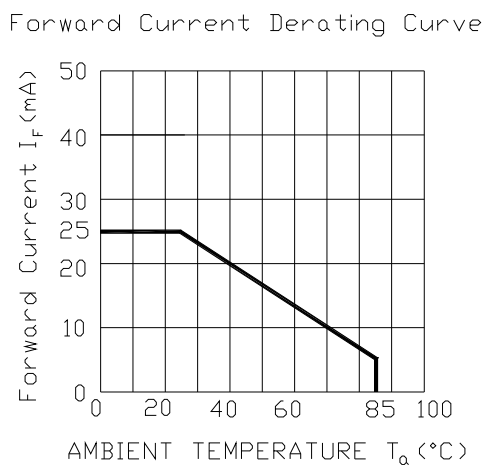
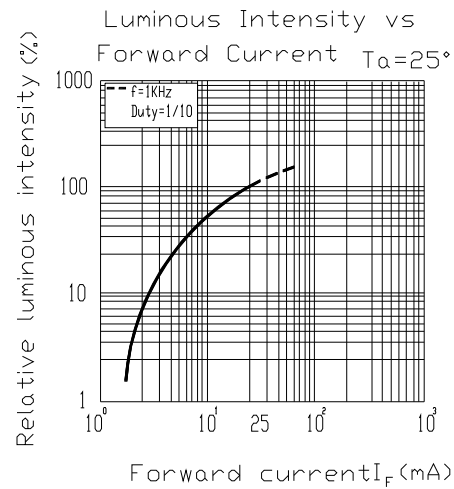
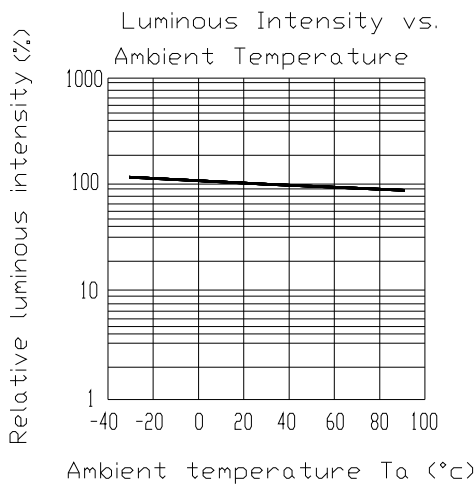
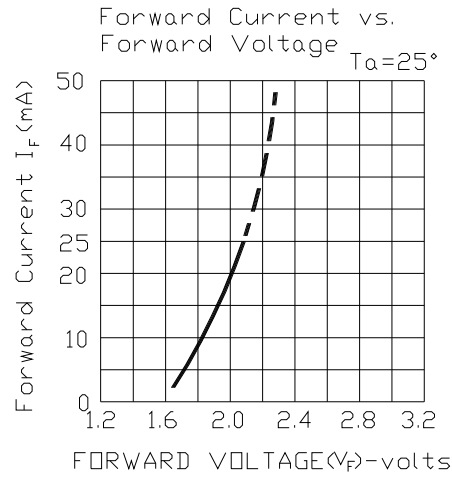
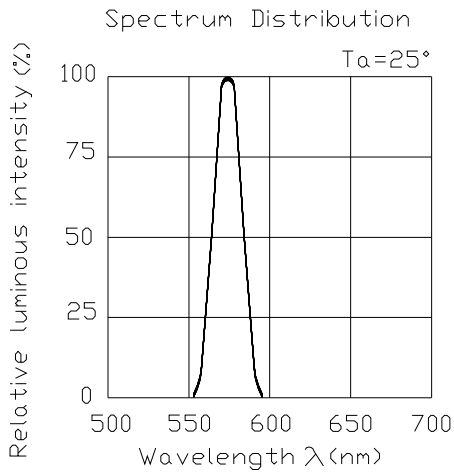



Technical Data Sheet

Side View LEDs (Height 0.8mm)

99-213/G6C-BQ1R2B/2C

Label Explanation

CAT: Luminous Intensity Rank

HUE: Dom. Wavelength Rank

REF: Forward Voltage Rank



Reel Dimensions

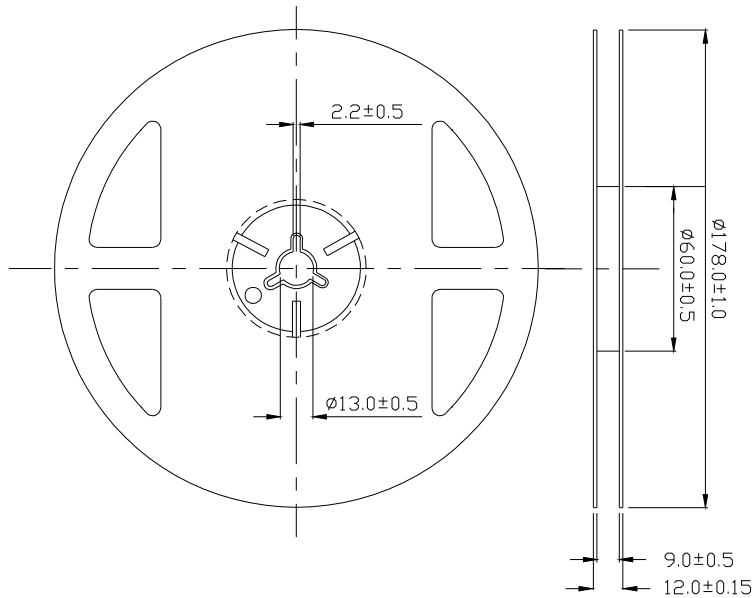

Note: The tolerances unless mentioned is ±0.1mm, Unit = mm

**Technical Data Sheet**

**Side View LEDs (Height 0.8mm)**

**99-213/G6C-BQ1R2B/2C**

**Carrier Tape Dimensions: Loaded Quantity 2000 pcs. Per Reel**

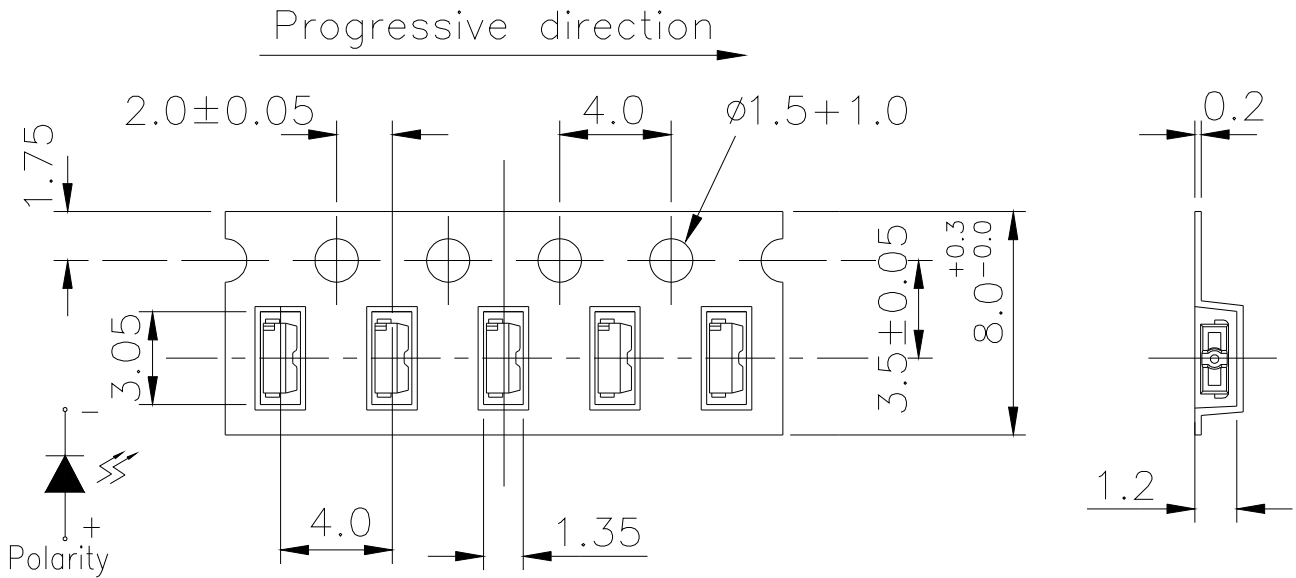

**Note:** The tolerances unless mentioned is ±0.1mm, unit = mm.

**Moisture Resistant Packaging**

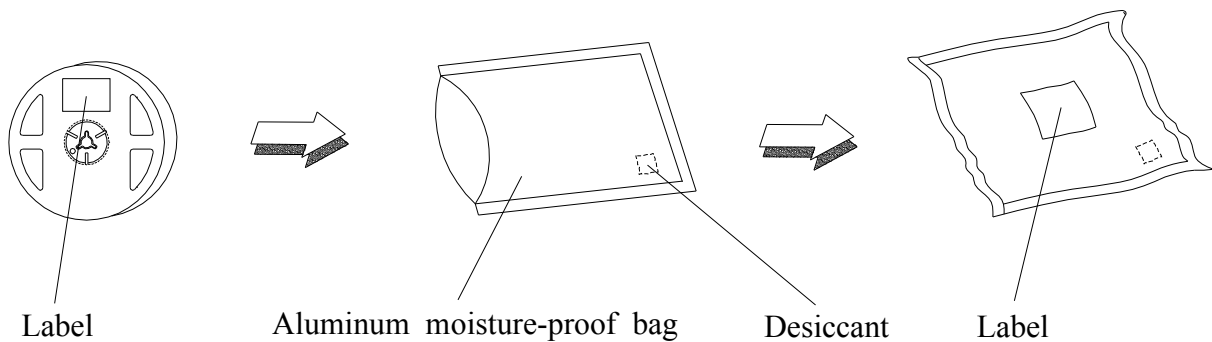

**Technical Data Sheet****Side View LEDs (Height 0.8mm)****99-213/G6C-BQ1R2B/2C****Reliability Test Items and Conditions**

The reliability of products shall be satisfied with items listed below.

Confidence level : 90%

LTPD : 10%

No.	Items	Test Condition	Test Hours/Cycles	Sample Size	Ac/Re
1	Reflow Soldering	Temp. : 260 ±5 Max. 10 sec.	6 Min.	22 PCS.	0/1
2	Temperature Cycle	H : +100 15min 5 min L : -40 15min	300 Cycles	22 PCS.	0/1
3	Thermal Shock	H : +100 5min 10 sec L : -10 5min	300 Cycles	22 PCS.	0/1
4	High Temperature Storage	Temp. : 100	1000 Hrs.	22 PCS.	0/1
5	Low Temperature Storage	Temp. : -40	1000 Hrs.	22 PCS.	0/1
6	DC Operating Life	I <sub>F</sub> = 20 mA / 25	1000 Hrs.	22 PCS.	0/1
7	High Temperature / High Humidity	85 /85%RH	1000 Hrs.	22 PCS.	0/1



**Technical Data Sheet****Side View LEDs (Height 0.8mm)****99-213/G6C-BQ1R2B/2C****Precautions for Use**

## 1. Over-current-proof

Customer must apply resistors for protection, otherwise slight voltage shift will cause big current change ( Burn out will happen ).

## 2. Storage

2.1 Do not open moisture proof bag before the products are ready to use.

2.2 Before opening the package: The LEDs should be kept at 30 °C or less and 90%RH or less.

2.3 After opening the package: The LED's floor life is 1 year under 30 °C or less and 60% RH or less.

If unused LEDs remain, it should be stored in moisture proof packages.

2.4 If the moisture absorbent material (silica gel) has faded away or the LEDs have exceeded the storage time, baking treatment should be performed using the following conditions.

Baking treatment: 60±5 °C for 24 hours

## 3. Soldering Condition

## 3.1 Pb-free solder temperature profile

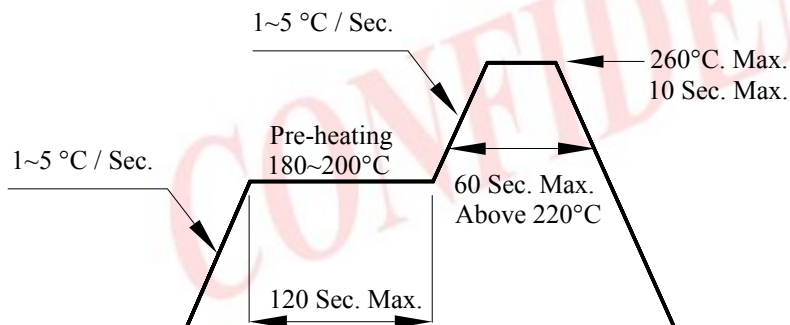

3.2 Reflow soldering should not be done more than two times.

3.3 When soldering, do not put stress on the LEDs during heating.

3.4 After soldering, do not warp the circuit board.

**Technical Data Sheet****Side View LEDs (Height 0.8mm)****99-213/G6C-BQ1R2B/2C****4. Soldering Iron**

Each terminal is to go to the tip of soldering iron temperature less than 350 for 3 seconds within once in less than the soldering iron capacity 25W. Leave two seconds and more intervals, and do soldering of each terminal. Be careful because the damage of the product is often started at the time of the hand solder.

**5. Repairing**

Repair should not be done after the LEDs have been soldered. When repairing is unavoidable, a double-head soldering iron should be used (as below figure). It should be confirmed beforehand whether the characteristics of the LEDs will or will not be damaged by repairing.

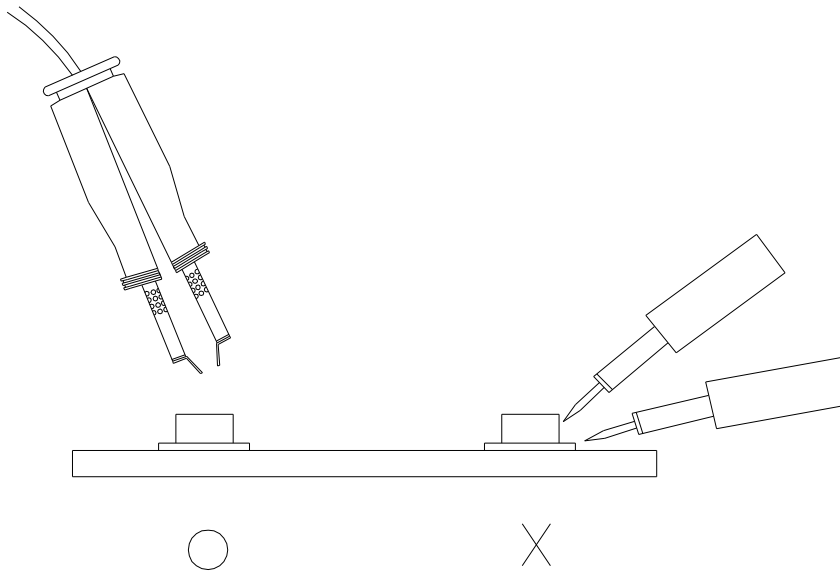
**EVERLIGHT ELECTRONICS CO., LTD.***Office: No 25, Lane 76, Sec 3, Chung Yang Rd,  
Tucheng, Taipei 236, Taiwan, R.O.C**Tel: 886-2-2267-2000, 2267-9936**Fax: 886-2267-6244, 2267-6189, 2267-6306**http://www.everlight.com*