

PRODUCT SPECIFICATION

SPEC. NO: T-0627-124B

DATE: Aug. 21, 2018

CUSTOMER'S PRODUCT NAME:

EMTEK PRODUCT NAME:

PIS3D18P-SERIES

THIS SPECIFICATION IS:

- FULLY ACCEPTED
 DENIED
 ACCEPTED UNDER THE FOLLOWING CONDITIONS



SIGNATURE: _____

DATE: _____

NAME(PRINT): _____

TITLE: _____

 **EMTEK CO., LTD.**

本文件內容全部或部份,未經兆欣科技股份有限公司同意不得以任何形式複製或其他用途
All rights reserved.This document or parts thereof,may not be reproduced by any means or used in any manner without written permission of EMTEK CO.,LTD.

FACTORY:

39, Chingao Rd., (305)Hsinpu,
Hsinchu Hsien, Taiwan, R. O. C

TEL: 03-5894-433

FAX: 03-5894-523

PRODUCT SPECIFICATION

SPEC. NO.

T-0627-124B



1. Scope

This specification applies Ferrite Power Inductance PIS3D18P-Series to be delivered to user.

2. Product Identification

PIS 3D18P - 100 □ - T

(1) (2) (3) (4) (5)

- (1) Product name
- (2) Shapes and dimensions
- (3) Inductance
100 : 10 uH
- (4) Tolerance
M=±20% , N=±30%
- (5) Taping Type

3. Shapes and Dimensions

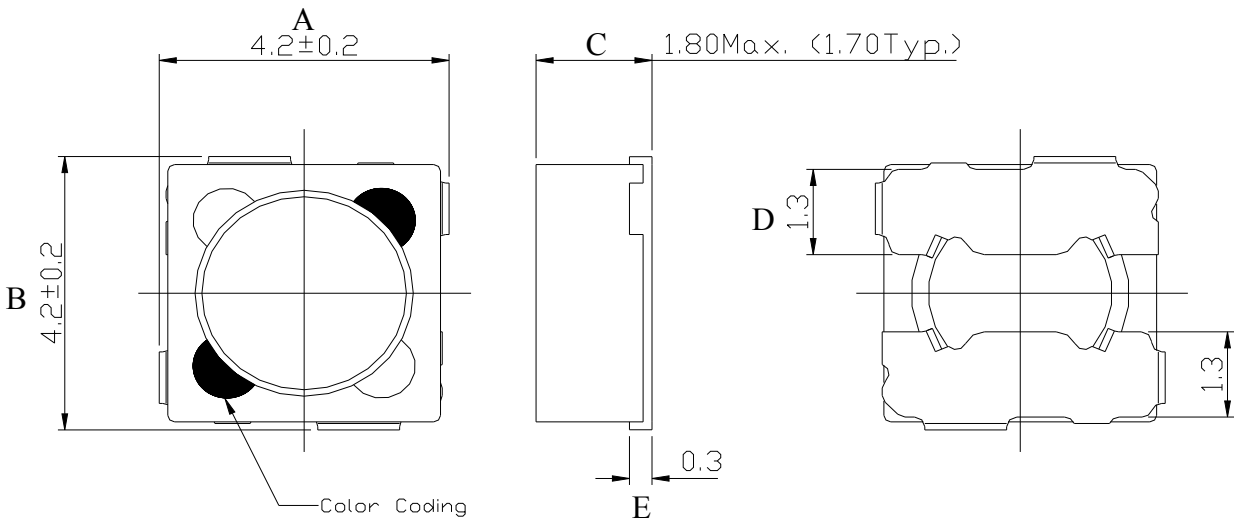

A:4.2±0.2 mm
 B:4.2±0.2 mm
 C:1.80 Max. (1.70Typ.)mm
 D:1.3 mm
 E:0.3 mm

Drawn by	Checked by	Approved by
Cindy Apr.21.2015	Zheng Apr.21.2015	Ju Apr.21.2015

PRODUCT SPECIFICATION

SPEC. NO.

T-0627-124B



4. Electrical Characteristics

Customer Part Number	Our Product Part Number	Inductance (uH)/KHz	Inductance Tolerance	Rdc Typ (Ω)	Idc Typ (mA)		Irms Typ (mA) T ↑ 25°C	Color Coding
					L ↓ 10%	L ↓ 35%		
	PIS3D18P-R27□-T	0.27/1	M	0.019	2900	5000	4600	Red
			N					
	PIS3D18P-R47□-T	0.47/1	M	0.029	2700	4000	3600	Blue
			N					
	PIS3D18P-R68□-T	0.68/1	M	0.032	2600	3500	3000	Gray
			N					
	PIS3D18P-1R0□-T	1.0/1	M	0.038	2600	3200	2400	Black
			N					
	PIS3D18P-1R2□-T	1.2/1	M	0.044	2400	3000	2200	Brown
			N					
	PIS3D18P-1R5□-T	1.5/1	M	0.050	2200	2700	2200	Red
			N					
	PIS3D18P-1R8□-T	1.8/1	M	0.058	1900	2400	2000	Orange
			N					
	PIS3D18P-2R2□-T	2.2/1	M	0.062	1800	2200	1900	Yellow
			N					
	PIS3D18P-2R7□-T	2.7/1	M	0.068	1700	2100	1800	Green
			N					
	PIS3D18P-3R3□-T	3.3/1	M	0.080	1500	1880	1650	Blue
			N					
	PIS3D18P-3R9□-T	3.9/1	M	0.084	1400	1800	1560	Violet
			N					
	PIS3D18P-4R7□-T	4.7/1	M	0.099	1220	1460	1400	Gray
			N					
	PIS3D18P-5R6□-T	5.6/1	M	0.110	1160	1480	1300	White
			N					
	PIS3D18P-6R8□-T	6.8/1	M	0.128	1020	1260	1200	Black
			N					
	PIS3D18P-8R2□-T	8.2/1	M	0.146	1000	1240	1150	Brown
			N					
	PIS3D18P-100□-T	10.0/1	M	0.165	900	1100	1050	Red
	PIS3D18P-120□-T	12.0/1	M	0.254	840	1000	800	Orange
	PIS3D18P-150□-T	15.0/1	M	0.320	740	880	720	Yellow

PRODUCT SPECIFICATION

SPEC. NO.

T-0627-124B



4. Electrical Characteristics

Customer Part Number	Our Product Part Number	Inductance (uH)/KHz	Inductance Tolerance	Rdc Typ (Ω)	Idc Typ (mA)		Irms Typ (mA) T ↑ 25°C	Color Coding
					L ↓ 10%	L ↓ 35%		
	PIS3D18P-180□-T	18.0/1	M	0.360	700	840	680	Green
	PIS3D18P-220□-T	22.0/1	M	0.418	600	740	650	Blue
	PIS3D18P-270□-T	27.0/1	M	0.450	560	700	600	Violet
	PIS3D18P-330□-T	33.0/1	M	0.620	460	580	580	Gray
	PIS3D18P-390□-T	39.0/1	M	0.650	450	560	480	White
	PIS3D18P-470□-T	47.0/1	M	0.790	430	520	450	Black
	PIS3D18P-560□-T	56.0/1	M	0.862	380	480	400	Brown
	PIS3D18P-680□-T	68.0/1	M	1.000	300	400	360	Red
	PIS3D18P-101□-T	100/1	M	1.380	260	320	360	Yellow
	PIS3D18P-151□-T	150/1	M	2.410	180	240	320	Yellow
	PIS3D18P-181□-T	180/1	M	3.420	180	240	290	Violet
	PIS3D18P-221□-T	220/1	M	3.900	150	230	290	Red
	PIS3D18P-331□-T	330/1	M	5.170	140	180	240	Orange
	PIS3D18P-471□-T	470/1	M	8.420	120	150	190	Green
	PIS3D18P-681□-T	680/1	M	10.300	100	130	160	Blue
	PIS3D18P-102□-T	1000/1	M	15.200	80	100	130	Black
	PIS3D18P-152□-T	1500/1	M	25.000	70	90	100	Black

PRODUCT SPECIFICATION

SPEC. NO.

T-0627-124B



1. When ordering, please specify tolerance and packaging codes. Ex : PIS3D18P-100M-T
Tolerance : $M=\pm 20\%$, $N = \pm 30\%$
Packaging : Clear tape and reel { standard }.
2. L, Idc : Agilent/HP 4284A , 1KHz with 1V.
3. Rdc : DIGITAL MILLIOHM METER Chroma 16502, or equivalent. (Typ: $\pm 30\%$ tolerance)
4. Idc for Inductance drop 10% or 35% from its value without current.
5. Irms for a 25°C rise above 25°C ambient.
6. Operating temperature range from -40°C to 125°C .

PRODUCT SPECIFICATION

SPEC. NO.

T-0627-124B

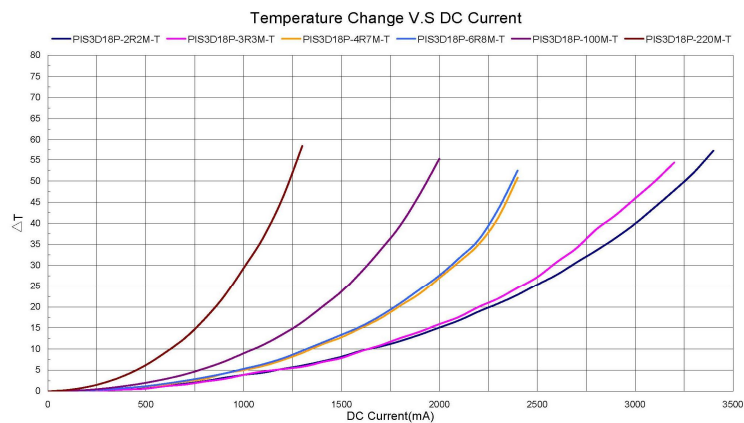
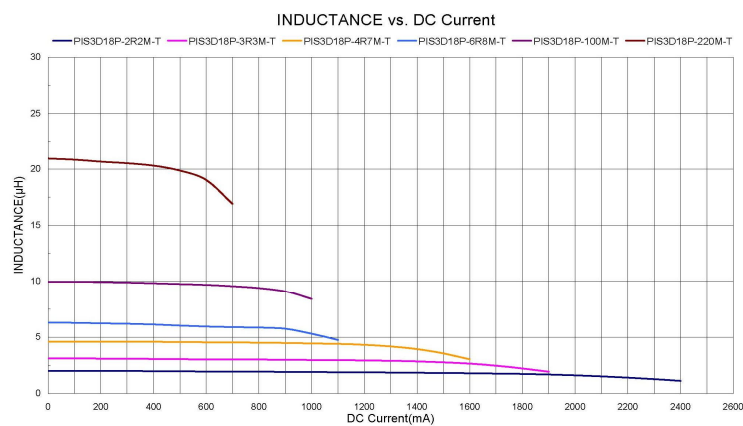
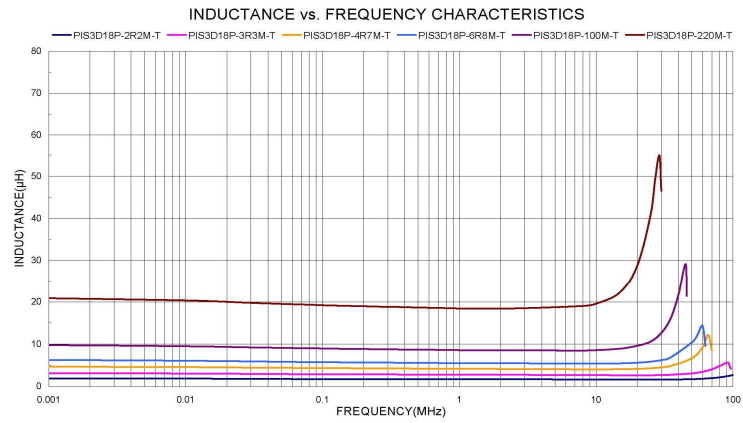

5. Material list

Item	Material
Core	Ferrite core
Wire	Copper wire
Epoxy	Epoxy
Base	Copper
Terminal	Cu / Ni / Sn

PRODUCT SPECIFICATION

SPEC. NO.

T-0627-124B



6. Reliability Test

Item	Specifications	Test conditions
Solderability	The metalized area must have 90% minimum solder coverage.	Dip pads in flux and dip in solder pot(96.5 Sn/3.5 Ag solder) at 255°C ±5°C.
Resistance to soldering heat	There must be no case deformation or change in dimensions. Inductance must not change more than the stated tolerance.	Inductors shall be reflowed onto a PC board using 96.5 Sn/3.5 Ag solder paste. Solder process shall be at a maximum temperature of 260°C. For 96.5 Sn/3.5 Ag solder paste:>217°C for 90 seconds
High temperature resistance	There must be no case deformation or change in dimensions. Inductance must not change more than the stated tolerance.	Inductors shall be subjected to temperature 125±2°C for 50±12 hours. Measure the test items after leaving the inductors at room temperature and humidity for 2 hours.
Static Humidity	Inductors must not have a shorted or openwinding.	Inductors shall be subjected to temperature 85±2°C and 90 to 95%RH. for ten 24-hours. Measure the test items after leaving the inductors at room temperature and humidity for 2 hours.
Component adhesion (push test)	Inductors shall be subjected to 0.5Kg	Inductors shall be reflow soldered (255°C ±5°C for 10 seconds) to a tinned copper substrate. A force gauge shall be applied to the side of the component. The device must withstand the stated force without a failure of the termination.
Low temperature resistance	There must be no case deformation or change in dimensions. Inductance must not change more than the stated tolerance.	Inductors shall be subjected to temperature -40±2°C for 48±12 hours. Measure the test items after leaving the inductors at room temperature and humidity for 1 to 2 hours.

PRODUCT SPECIFICATION

SPEC. NO.

T-0627-124B



Item	Specifications	Test conditions
Resistance to solvent	There must be no case deformation, change in dimensions, or obliteration of marking.	Inductors must withstand 6 minutes of alcohol or water.
Thermal shock	There must be no case deformation or change in dimensions. Inductance must not change more than the stated tolerance.	Inductors shall be subjected to 10 cycles to the the following temperature cycle: <div style="text-align: center;"> </div> <p>Measure the test items after leaving the inductors at room temperature and humidity for 2 hours.</p>

PRODUCT SPECIFICATION

SPEC. NO.

T-0627-124B



7. Packaging

The packaging must be done not to receive any damage during transporting and storing.

7-1 Tape dimensions

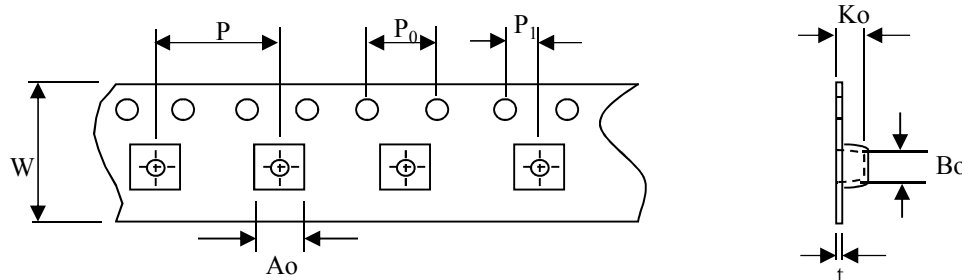
(Dimensions in mm; Tolerance : ± 0.1)

Symbol	W	P	P ₀	P ₁	A _o	B _o	K _o	t
Dimension	12	8	4	2	4.5	4.5	1.9	0.25

7-2 Reel dimensions

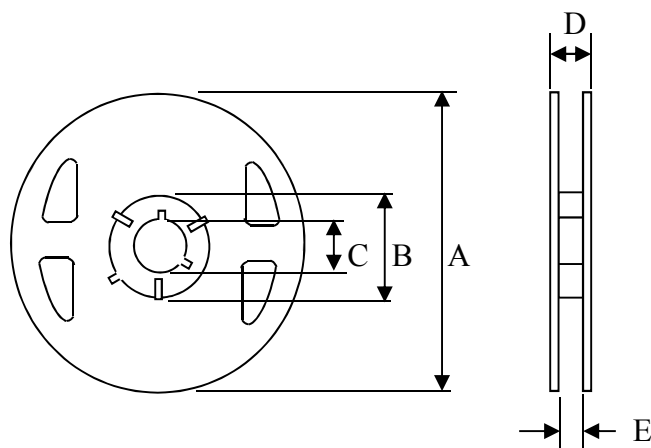

(Dimensions in mm)

Symbol	T
A	180
B	60
C	13
D	16
E	13.2

7-3 Tapping figure

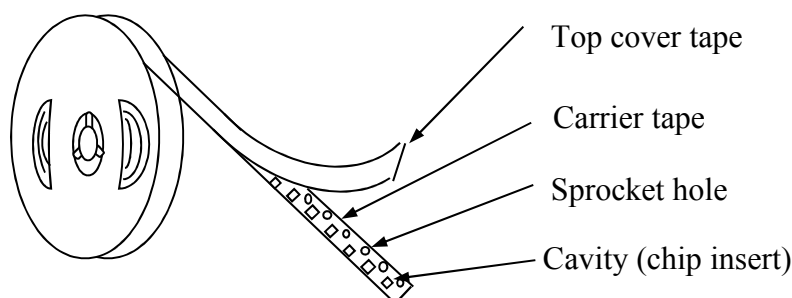

PRODUCT SPECIFICATION

SPEC. NO.

T-0627-124B



7-4 Packaging Form

There shall not continuation more than two vacancies of the product.

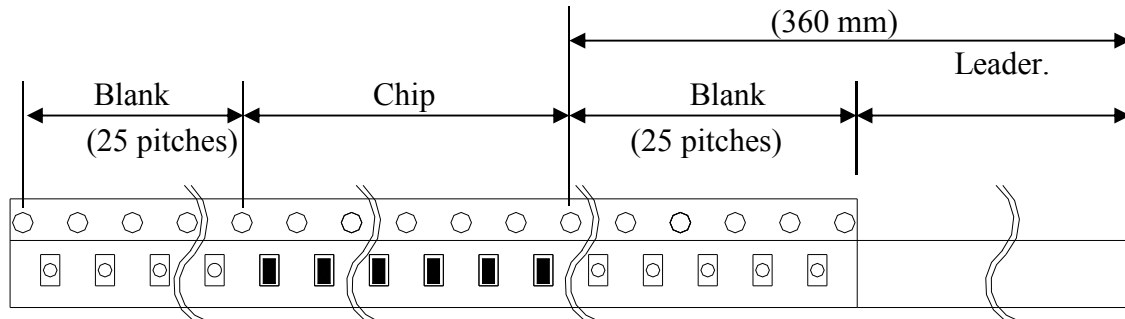

7-5 Cover Tape Peel Strength

The force for tearing off cover tape is 0.1~0.6(N) in the arrow direction at the following conditions:

Temperature : 5 ~ 35°C

Humidity : 45 ~ 85%

Atmospheric pressure : 860 ~ 1060 hpa

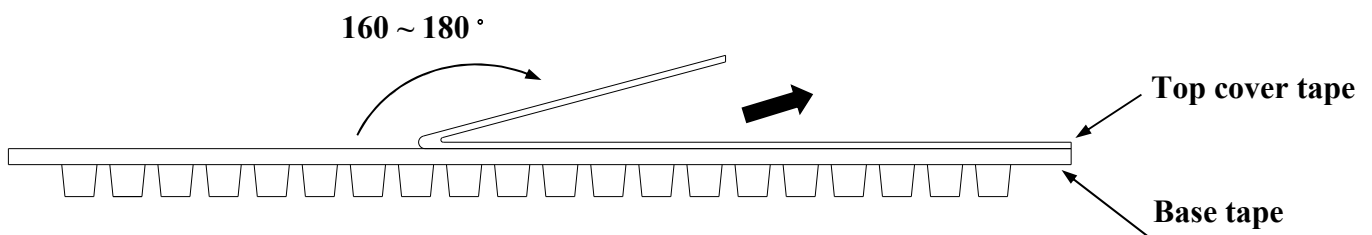

7-6 Packing Quantity

φ180 mm reel type : 1,000 pcs./reel

PRODUCT SPECIFICATION

SPEC. NO.

T-0627-124B



8. Recommended Soldering Conditions (Please use this product by reflow soldering)

8-1 Recommended Footprint

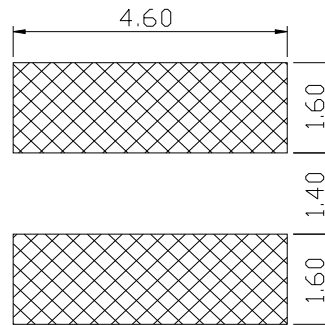

Unit: mm

Recommand Pad Layout

8-2 Recommended Reflow Pattern

Reflow : until two times

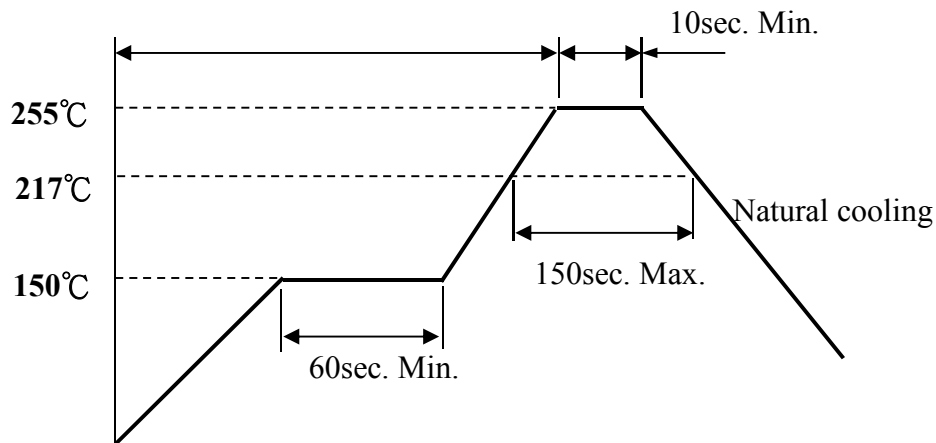

8-3 Iron Soldering

Use a solder iron of less than 30W when soldering ,do not allow the soldering iron tip directly touch the Ceramic body outside of terminal electrode.

5 seconds max. at 260°C .

9. Attention in Case of Using

In case of using product ,please avoid following matters:

Splashing water or salt water

Dew condenses

Toxic gas (Hydrogen sulfide, Sulfurous acid ,Chlorine, Ammonia)

Vibrations or shocks which exceed the specified condition

Please be careful for the stress to this product by board flexure or something after the mounting.

PRODUCT SPECIFICATION

SPEC. NO.

T-0627-124B



10. Others

- 10-1 Operating temperature range : Ferrite Series :-40~+125°C
- 10-2 The part temperature (ambient + temp rise) should not exceed 125°C under worse operating conditions. Circuit design, component placement, PWB trace size and thickness, airflow and other cooling provision all affect the part temperature.
- 10-3 Storage condition : Temperature 20°~25°C , Relative Humidity 40%~60%
- 10-4 Recommended wire wound inductors should be used within 6 months from the time of delivery.