

CC6900

Fully Integrated, Hall Effect-Based Linear Current Sensor IC with a Low-Resistance Conductor 5A/10A/20A/30A Series

GENERAL DESCRIPTION

The CC6900 device is an electrically isolated monolithic current sensor based on Hall Effect. The device provides precise and economical solutions for AC or DC current sensing in industrial, commercial and communication equipments. It is provided in a small, surface mount SOP8 package with current sensing range of 5A/10A/20A/30A. Customers can easily complete their PCB design and implementation.

The CC6900 device consists of a precise, low-offset, linear Hall circuit with a copper conduction path located near the surface of the die. When current flows through the copper conduction path, a magnetic field generates. Meanwhile the Hall circuit converts this magnetic signal to output voltage signal.

The Hall circuit based on BiCOMS process integrates a high sensitivity Hall element, oscillator, Hall signal pre-amplifier, temperature compensation circuit, dynamic offset cancellation circuit, sensitivity trimming circuit and output amplifier. The temperature compensation circuit ensures good temperature stability of CC6900. Chopper stabilization technique is applied to the Hall circuit to minimize offset voltage. High chopping frequency up to 1MHz makes CC6900 80kHz bandwidth and ultra-short step input response time down to typical 2 μ s. Because of this chopper stabilization approach, the output voltage from the Hall IC is desensitized to the effects of temperature and mechanical stress.

Internal copper conductor's resistance is typical 1.5m Ω , which provides much less power loss than the universal resistor sampling method. Zero current output voltage is 50%VCC. When power supply voltage is 5V, the linear output voltage range is 0.2~4.8V, a range of 0.5~4.5V is recommended for better linearity.

Current sensing range of CC6900 is programmed to a fixed value after packaging, and the range of 5A/10A/20A/30A is available. It's operating ambient temperature range is -40~125°C.

FEATURES

- ◆ Built-in high sensitivity Hall sensor
- ◆ 5V, single supply operation
- ◆ Zero current output voltage is 50%VCC
- ◆ Typical primary conductor's resistance is 1.5m Ω
- ◆ Current sensing range available: 5A/10A/20A/30A
- ◆ 80kHz bandwidth
- ◆ 2 μ s output rise time in response to step input current
- ◆ 100V_{RMS} isolation voltage between pins 1-4 and 5-8
- ◆ Total output error 1% at T_a=25°C and 3% at T_a= -40~125°C
- ◆ Output is desensitized to mechanical stress
- ◆ ESD (HBM) 6000V
- ◆ Operating ambient temperature: -40~125°C

APPLICATIONS

- ◆ Motor controller
- ◆ Load detection and management
- ◆ Switch-mode power supplies
- ◆ Over-current fault protection

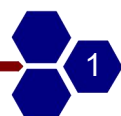

FUNCTION BLOCK DIAGRAM

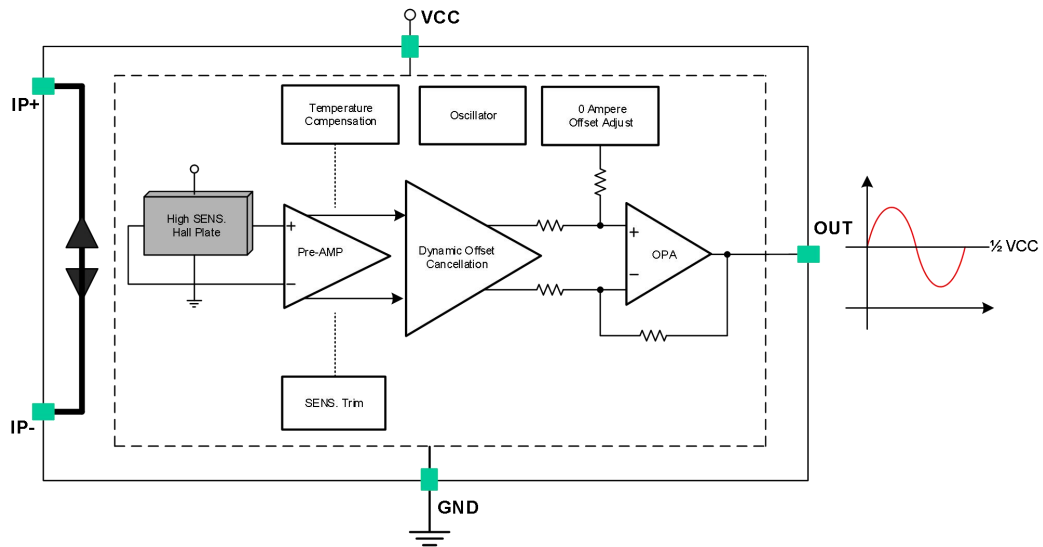

ORDERING INFORMATION

Part No.	SENS. (mV/A)	Package	Packing Form
CC6900SO-5A	400	SOP8	tape reel, 2000 pcs/reel
CC6900SO-10A	200	SOP8	tape reel, 2000 pcs/reel
CC6900SO-20A	100	SOP8	tape reel, 2000 pcs/reel
CC6900SO-30A	67	SOP8	tape reel, 2000 pcs/reel

PINOUT DIAGRAM

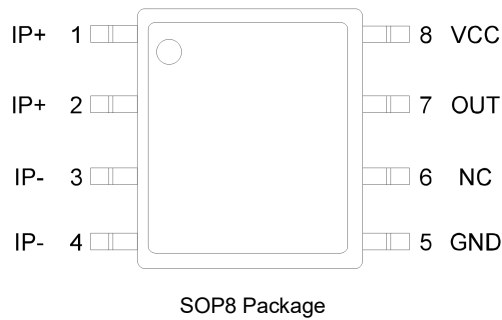

Name	Number	Description	Name	Number	Description
IP+	1	Current Sampled +	GND	5	Ground
IP+	2	Current Sampled +	NC	6	Must be floated
IP-	3	Current Sampled -	OUT	7	Analog Voltage Output
IP-	4	Current Sampled -	VCC	8	Power Supply

ABSOLUTE MAXIMUM RATINGS

Parameter	Symbol	Value	Unit
Power Supply	V _{CC}	7	V
Output Voltage	V _{OUT}	-0.3~V _{CC} +0.3	V
Output Source Current	I _{OUT (SOURCE)}	400	uA
Output Sink Current	I _{OUT (SINK)}	30	mA
Isolation Voltage	V _{ISO}	100	VAC
Operating Ambient Temperature	T _a	-40~125	°C
Junction Temperature	T _J	165	°C
Storage Temperature	T _S	-55~150	°C
Magnetic Flux Density	B	Not Limited	mT
Electrostatic Discharge Voltage(HBM)	ESD(HBM)	6000	V
Overcurrent Transient Tolerance	I _P	1pulse, 100ms	100A

Note: Stresses beyond those listed under *Absolute Maximum Ratings* may cause permanent damage to the device. Exposure to absolute-maximum-rated conditions for extended periods may affect device reliability.

RECOMMENDED OPERATING CONDITIONS

Parameter	Symbol	Min.	Max.	Unit
Power Supply	V _{CC}	4.5	5.5	V
Operation Temperature	T _a	-40	125	°C
Sense Current Capability	I _P	-30	30	A

Note: The actual maximum continuous sensing current through IC must be calculated according to actual ambient temperature(T_a), IC's thermal resistance(θ_{JA}) and maximum junction temperature(T_J).

ELECTRICAL PARAMETERS

T_a=25°C and V_{CC}=5V, unless otherwise specified

Parameter	Symbol	Conditions	Min.	Typ.	Max.	Unit
Power Supply	V _{CC}	-	4.5	-	5.5	V
Supply Current	I _{CC}	OUT pin floated	-	5	8	mA
Output Capacitance Load	C _L		-	-	1	nF
Output Resistive Load	R _L		20	-	-	kΩ
Propagation Time	t _d			1	1.2	us
Rise Time	t _r		-	2	3.6	us
Bandwidth	BW	-3dB, T _a =25°C	-	80	-	kHz
Nonlinearity	LinERR		-	0.4	1	%
Symmetry	SymERR		-	0.8	1.5	%
Zero Current Output Voltage	V _{OUT(Q)}		2.48	2.5	2.52	V
Power-on Time	T _{POR}	Output rising from 0 to 90% of steady-state	-	10	-	us
Res. of Primary Conductor	R _P		-	1.5	1.8	mΩ
Junction-to-Ambient Thermal Resistance	θ _{JA}	1500 mm ² of 2 oz. copper on 1、 2 and 3、 4 pin	-	25	-	°C/W

5A PERFORMANCE CHARACTERISTICS

Parameter	Symbol	Conditions	Min.	Typ.	Max.	Unit
Current Accuracy Range	I_P	-	-5	-	5	A
Sensitivity	Sens	full range of I_P	390	400	410	mV/A
Noise	$V_{NOISE(PP)}$		-	50	-	mV
Zero Current Output Slope	$\Delta V_{OUT(Q)}$		-	0.26	-	mV/°C
Sensitivity Slope	$\Delta Sens$		-	0.054	-	mV/A/°C
Total Output Error	E_{TOT}		-3.0	-	3.0	%

10A PERFORMANCE CHARACTERISTICS

Parameter	Symbol	Conditions	Min.	Typ.	Max.	Unit
Current Accuracy Range	I_P	-	-10	-	10	A
Sensitivity	Sens	full range of I_P	195	200	205	mV/A
Noise	$V_{NOISE(PP)}$		-	30	-	mV
Zero Current Output Slope	$\Delta V_{OUT(Q)}$		-	0.30	-	mV/°C
Sensitivity Slope	$\Delta Sens$		-	0.027	-	mV/A/°C
Total Output Error	E_{TOT}		-3.0	-	3.0	%

20A PERFORMANCE CHARACTERISTICS

Parameter	Symbol	Conditions	Min.	Typ.	Max.	Unit
Current Accuracy Range	I_P	-	-20	-	20	A
Sensitivity	Sens	full range of I_P	95	100	105	mV/A
Noise	$V_{NOISE(PP)}$		-	20	-	mV
Zero Current Output Slope	$\Delta V_{OUT(Q)}$		-	0.34	-	mV/°C
Sensitivity Slope	$\Delta Sens$		-	0.017	-	mV/A/°C
Total Output Error	E_{TOT}		-3.0	-	3.0	%

30A PERFORMANCE CHARACTERISTICS

Parameter	Symbol	Conditions	Min.	Typ.	Max.	Unit
Current Accuracy Range	I_P	-	-30	-	30	A
Sensitivity	Sens	full range of I_P	64	67	70	mV/A
Noise	$V_{NOISE(PP)}$		-	20	-	mV
Zero Current Output Slope	$\Delta V_{OUT(Q)}$		-	0.35	-	mV/°C
Sensitivity Slope	$\Delta Sens$		-	0.010	-	mV/A/°C
Total Output Error	E_{TOT}		-3.0	-	3.0	%

TYPICAL APPLICATION CIRCUITS

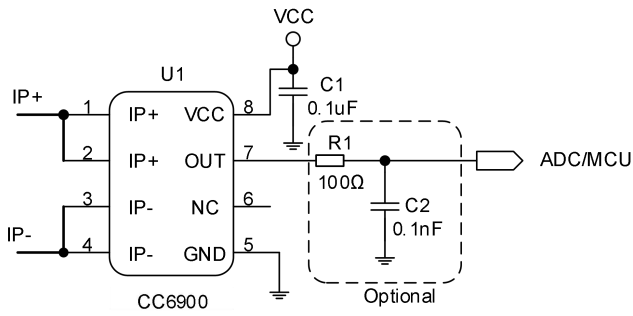

Typical Output Application

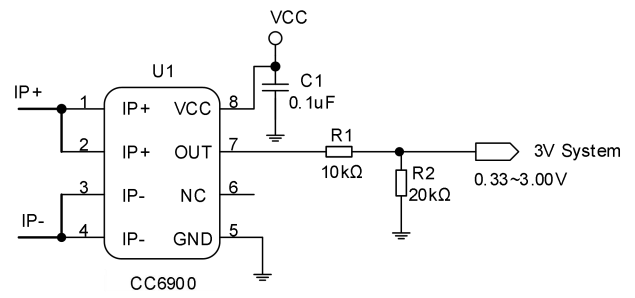

Signal Attenuation Circuit

Note: The driving capacity is calculated as 0.25ma, and the sum of resistances(R1+R2) should be greater than 20kΩ

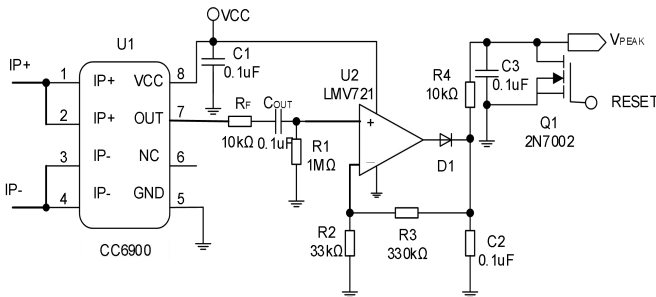

Peak Current Detection

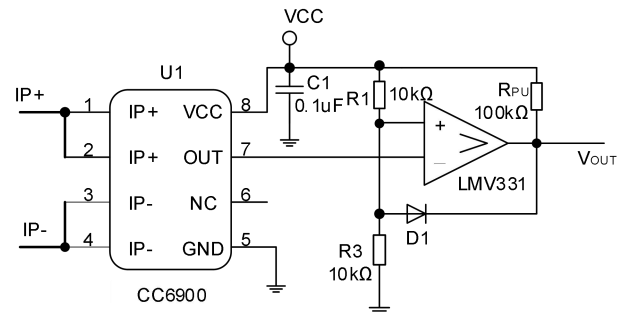

Over Current Fault Latch

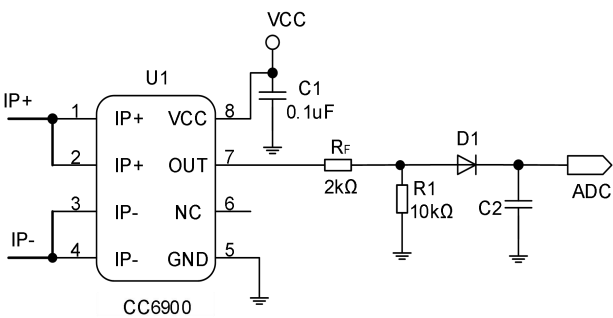

Rectifier output, instead of current transformer application

Output Characteristic

The static output point ($I_P = 0A$) of CC6900 is $V_{CC} / 2$.

When the current increases, the V_{OUT} increases until the saturation voltage of the output operational amplifier ($V_{CC} - \text{rail voltage}$); when the current decreases, the V_{OUT} decreases until the saturation voltage ($GND + \text{rail voltage}$) of the Output Op Amp. Crosschip ensures the accuracy and linearity of V_{OUT} in the range of 0.5 ~ 4.5V. In order to ensure the consistency of mass manufacturing, there is a certain margin in this range, but it is not recommended for customers to use this margin.

When the input current exceeds the range, the output of V_{OUT} is close to the rail voltage of the power supply. When the input current does not exceed the tolerance limit of the chip, the voltage will always be maintained. After the input current returns to the range, the output of V_{OUT} will return to normal without any damage to the chip.

Product Name	Input Current	Sensitivity (mV/A)	Calculation Formula (Note 1)
CC6900SO-5A	-5A ~ +5A	400	$V_{OUT} = V_{CC} / 2 + 0.400 \times I_P(A) \dots\dots(V)$
CC6900SO-10A	-10A ~ +10A	200	$V_{OUT} = V_{CC} / 2 + 0.200 \times I_P(A) \dots\dots(V)$
CC6900SO-20A	-20A ~ +20A	100	$V_{OUT} = V_{CC} / 2 + 0.100 \times I_P(A) \dots\dots(V)$
CC6900SO-30A	-30A ~ +30A	67	$V_{OUT} = V_{CC} / 2 + 0.067 \times I_P(A) \dots\dots(V)$

Note: the formula is only applicable to DC current calculation. When AC current is applied, pay attention to $I_{PEAK} = 1.414 \times I_{RMS}$ and the positive & negative current direction.

OUTPUT WAVEFORMS AND CURVES

T_a=25°C and VCC=5V, unless otherwise specified

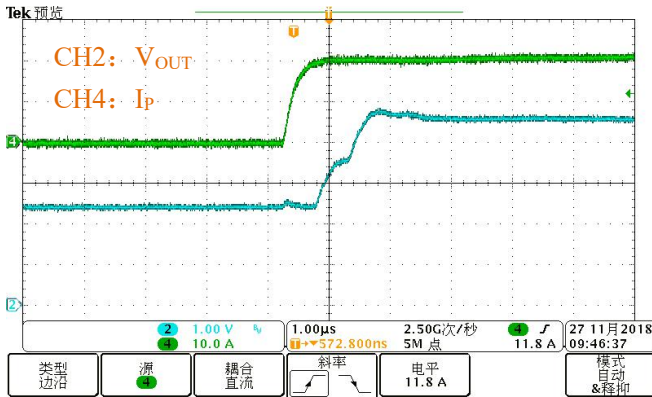

V_{OUT} vs. I_P (Positive Current Rising Edge Response) (20A)

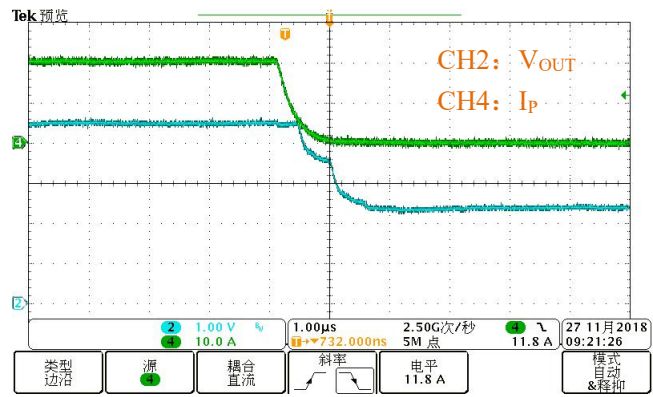

V_{OUT} vs. I_P (Positive Current Falling Edge Response) (20A)

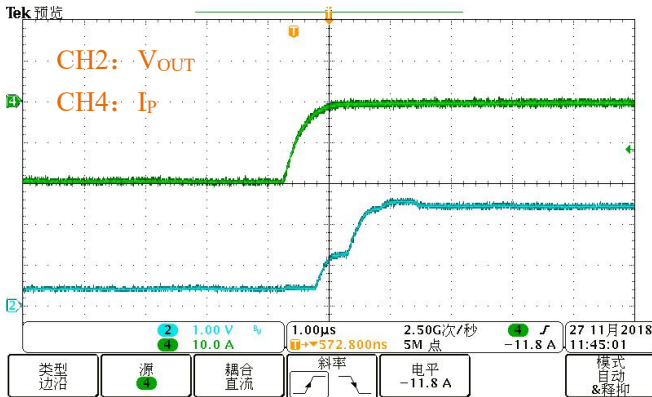

V_{OUT} vs. I_P (Negative Current Rising Edge Response) (20A)

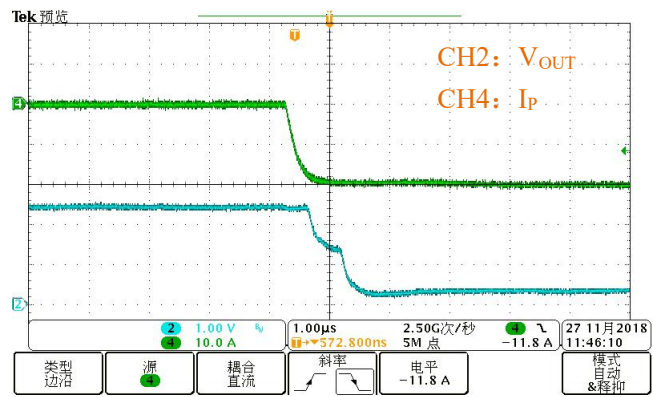

V_{OUT} vs. I_P (Negative Current Falling Edge Response) (20A)

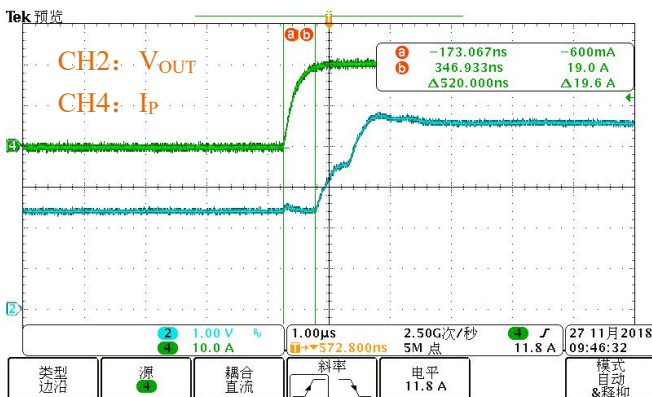

Propagation Time (20A)

All of these pictures use the same oscilloscope settings as follows:

1. I_P Current Channel: 10A/div, 1us/div, DC coupling, non-inverting
2. V_{OUT} Voltage Channel: 1V/div, 1us/div, DC coupling, non-inverting
3. Trigger Mode: I_P Current Channel, Edge, Trigger Level:11.8A

OUTPUT WAVEFORMS AND CURVES

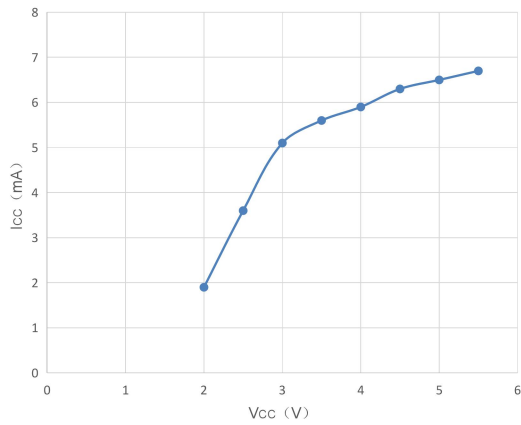

I_{CC} vs. V_{CC}

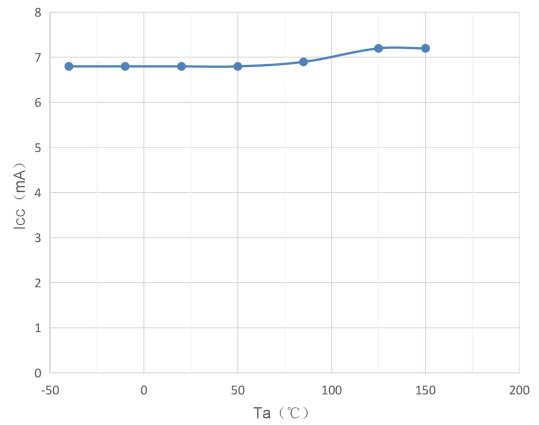

I_{CC} vs. T_a

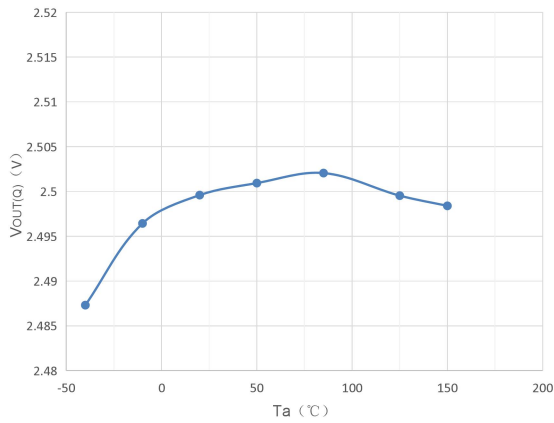

V_{OUT(Q)} vs. T_a

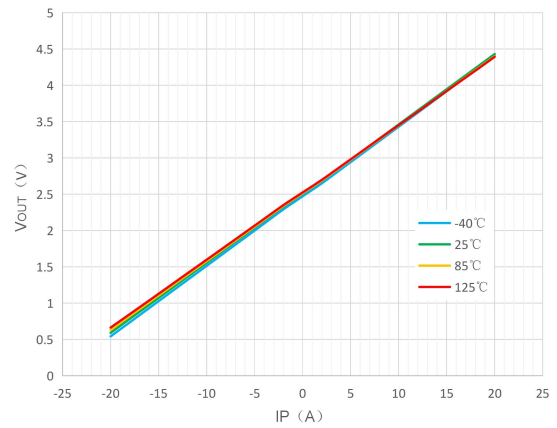

V_{OUT} vs. I_P (20A)

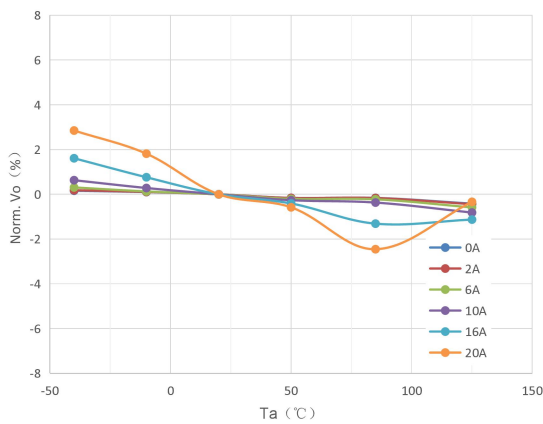

V_{OUT} error vs. T_a

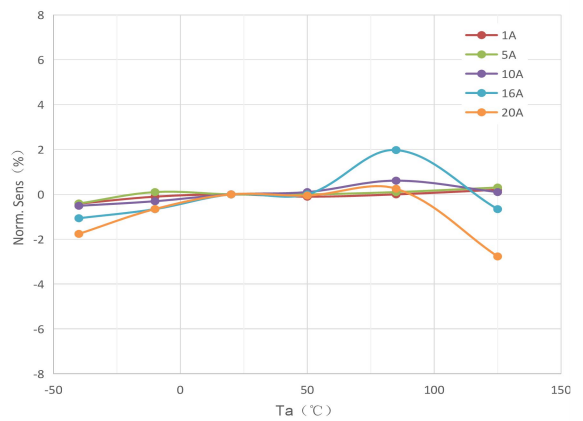

Sens error vs. T_a

PACKAGE INFORMATION

SOP8 PACKAGE

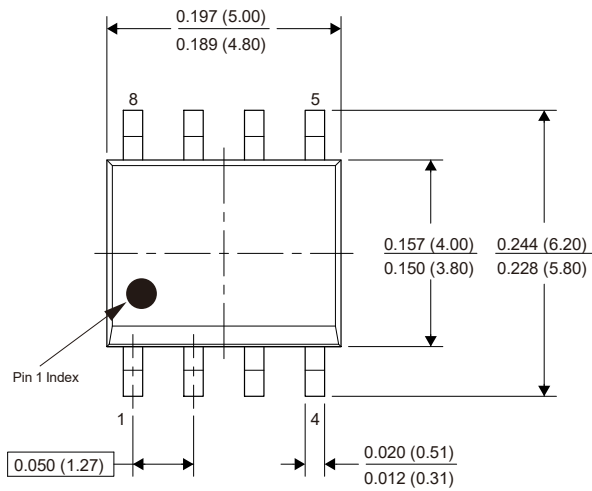

Note:

1. All dimensions are in millimeters.

Marking:

1st Line: CC6900SO - Device Name

2nd Line: + ELC-XXA - I_P Range XX A

3rd Line: XXYYWW

XX - assembler code

YY - assembly year (last 2 digits)

WW - assembly week number

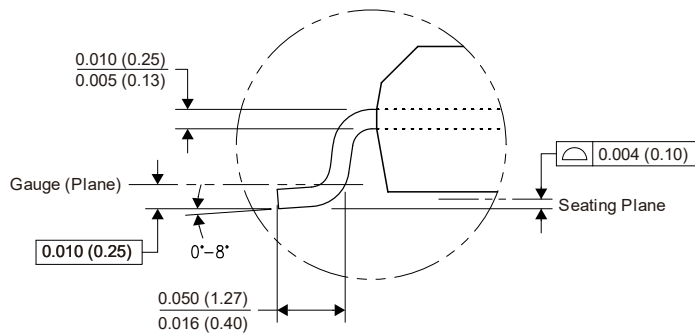
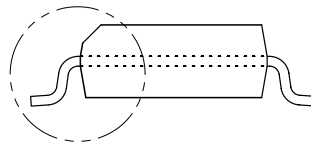
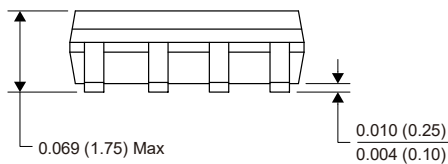

Package Reference

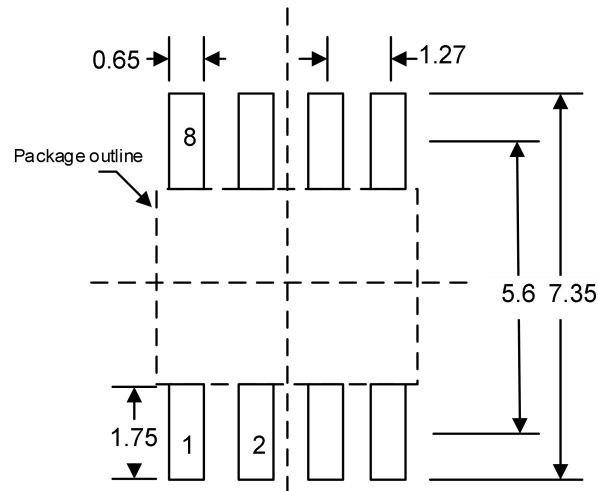

Note: it is not recommended to route wires under the chip. It is **forbidden** to route wires with high current

Packaging & Taping

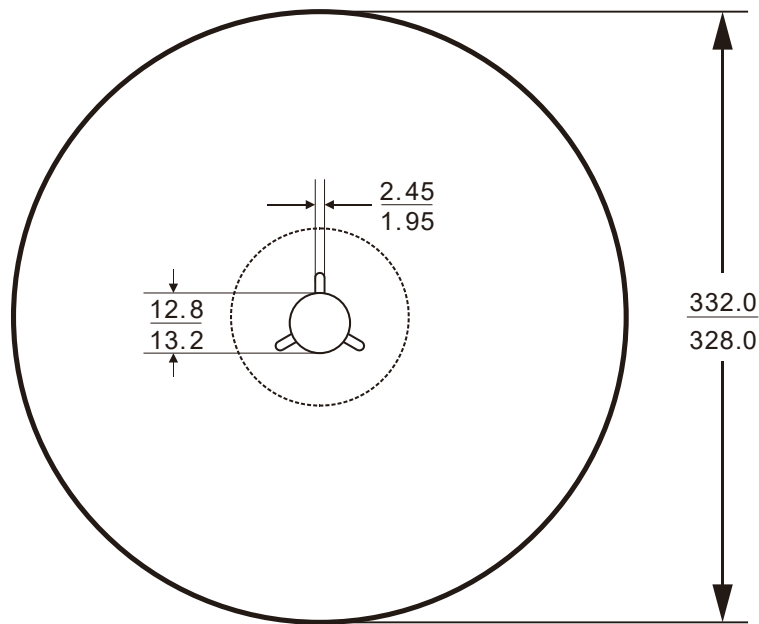

Information of Reel size

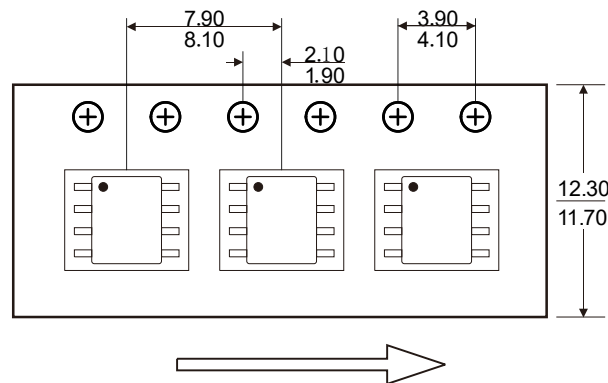

User Direction of Feed

Note: The space between the front and back of each tape is 50 ± 2 grids

CrossChip

CrossChip Microsystems Inc. was founded in 2013, is a national high-tech enterprise, engaged in integrated circuit design and sales. The company has strong technical strength, has more than 50 kinds of patents, mainly used in Hall sensor signal processing, with the following product lines:

- ✓ High precision linear Hall sensor
- ✓ All kinds of Hall switches
- ✓ Single phase motor drive
- ✓ Single chip current sensor
- ✓ AMR Magnetoresistance sensor

Contact us

Chengdu

Address: 4th floor, unit 2, building 3, No. 88, Tianchen Road, Gaoxinxi Zone, Chengdu, Sichuan Province

Tel: + 86 - 28 - 87787685

Email: support@crosschipmicro.com

Website: <http://www.crosschipmicro.com>

Shenzhen

Address: 605 room, 6F, Beike building, NO.18 Keyuan Rd, Yuehai Street, Nanshan District, Shenzhen

Shanghai

Address: Makeblock, 3 / F, magic square community, 4476 Huyi Road, Jiading District, Shanghai