

CC6410/1

5V/12V 400mA Single Coil Fan Driver with Auto-start and FG or RD

General Description

CC6410/1 is a one-chip solution for driving single-coil DC brushless fans and motors, which is fabricated with innovative high voltage BiCMOS process. The IC includes high sensitivity hall sensor, chopper stabilized amplifier, dynamic offset cancellation, thermal protection and a low $R_{DS(on)}$ full bridge driver.

CC6410/1 has auto-restart function. When the fan is mechanically blocking, IC will shutdown the coil current and restart every time until the blocking release. Thus, the current of coil is low enough and protect the fan from over-heating.

CC6410/1 has the functions of speed detection (CC6410) and locked rotor detection (CC6411). The open leakage output mode is convenient for the connection between the product and the external interface.

CC6410/1 integrated reverse connection protection function, without external reverse connection protection diode, saving cost for customers.

CC6410/1 is available in SOT335 package. The operation temperature range is $-40\sim 125^{\circ}\text{C}$.

Features

- ◆ Built-in High Sensitivity Hall Sensor
- ◆ Fan Power Reverse connection protection
- ◆ Low Power Consumption, Typical 2.5mA
- ◆ Locked Rotor Protection and Auto-restart
- ◆ Maximum Continuous Driving Current: 400mA
- ◆ Tachometer Output FG(CC6410) or Alarm Output RD(CC6411)
- ◆ Superior Temperature Stability
- ◆ Resistant to Physical Stress
- ◆ ESD (HBM) 6000V

Application

- ◆ Single Phase BLDC Fans
- ◆ Single Phase BLDC Motors

Function Block Diagram

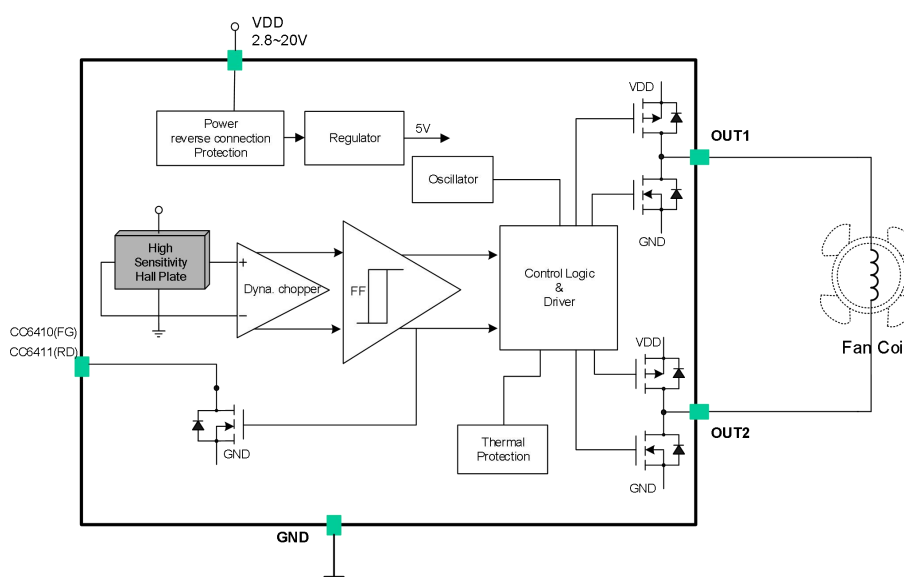

Ordering Information

Part No.	Description	Package Code
CC6410SS	SOT335	Tape reel, 10000pcs/reel
CC6411SS	SOT335	Tape reel, 10000pcs/reel

PIN Configurations

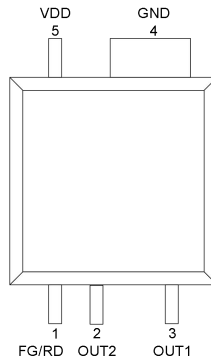

SOT335

Pin Name	Number	Function
	SOT335	
VDD	5	Supply Voltage
OUT1	3	H bridge output 1
OUT2	2	H bridge output 2
GND	4	GND
FG/RD	1	Tachometer/Alarm

Absolute Maximum Ratings

Parameter	symbol	value	unit
Fan Supply Voltage	V_{DD}	20	V
Peak Output Current	I_{OUTP}	1000	mA
Continuous Output Current	I_{CONT}	400	mA
Operating Temperature Range	T_A	-40~125	°C
Junction Temperature	T_J	160	°C
Thermal Resistance Junction - Ambient	R_{thJA}	195	°C/W
Thermal Resistance Junction - Surface	R_{thJC}	35	
Storage Temperature	T_S	-55~150	°C
Magnetic Flux Density	B	Unlimited	mT
ESD Susceptibility (HBM)	ESD(HBM)	6000	V

Note:

- 1) The bottom heat dissipation welding plate needs to be welded on the PCB.
- 2) Exceeding the absolute maximum ratings may cause permanent damage. Exposure to absolute-maximum rated conditions for extended periods may degrade device reliability.

Recommended Operation Conditions

Parameter	symbol	MIN	MAX	unit
Fan Supply Voltage	V _{DD}	2.8	20	V
Continuous Output Current	I _{OUTC}	-	400	mA
Ambient Temperature	T _A	-20	85	°C

Electrical Parameters (V_{DD}=18V @ 25°C room temperature, unless specified otherwise)

Parameter	Symbol	Condition	Min	Typ.	Max	Unit
Fan Supply Voltage	V _{DD}	-	2.8	-	20	V
Supply Current	I _{DD}	-	1.5	2.5	4	mA
Output V _{SAT} (sink)	V _{SAT}	V _{DD} =14V, I _{out} =200mA	0.15	0.2	0.25	V
Output V _{SAT} (source)		V _{DD} =14V, I _{out} =200mA	V _{DD} -0.5	V _{DD} -0.4	V _{DD} -0.2	V
Output Rise Time	t _r	R _L =820Ω, C _L =20pF	1	3	5	us
Output Fall Time	t _f	R _L =820Ω, C _L =20pF	1	3	5	us
Output Dead Time	t _{DEAD}	R _L =820Ω, C _L =20pF	10	30	50	us
Locked Rotor ON Time	T _{ON}	V _{DD} >7V	0.29	0.33	0.37	s
Locked Rotor OFF Time	T _{OFF}	V _{DD} >7V	1.7	2.0	2.3	s
Reverse Current	I _{REV}	V _{DD} = -25V	-	-	1	uA
FG/RD Output Saturation Voltage Drop	V _{OL}	I=10mA	25	50	75	mV
FG/RD Output Clamp Voltage	V _{CALMP}	-	21	23	25	V

Magnetic Specifications

Parameter	Symbol	Min	Typ.	Max	Unit
Operate Point	B _{OP}	5	25	45	Gauss
Release Point	B _{RP}	-45	-25	-5	Gauss
Hysteresis	B _{HYS}	20	50	80	Gauss

Driver Output vs. Magnetic Pole

Parameter	Test Condition	OUT1	OUT2
North Pole	B < B _{OP}	High	Low
South Pole	B > B _{RP}	Low	High

Typical Application Circuit

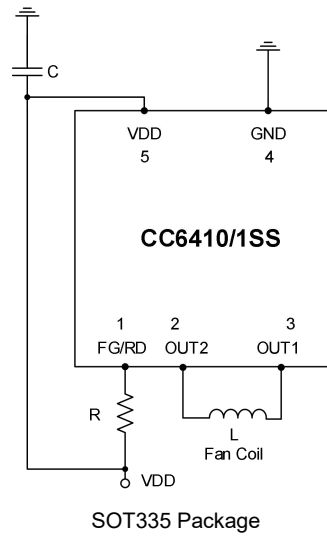

NOTE:

- a) It is recommended to place a bypass capacitor at the power pin of the chip to the ground.

Waveform

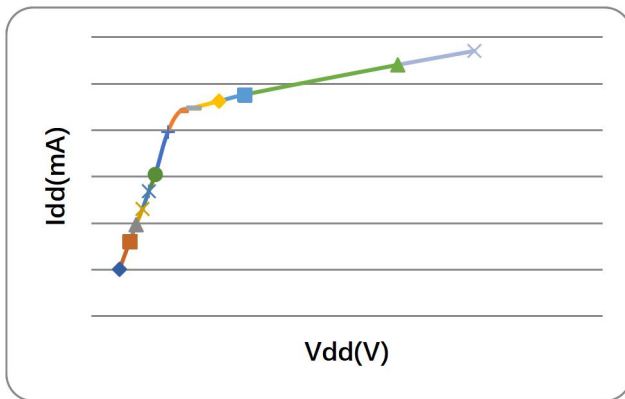

I_{DD} vs. V_{IN}

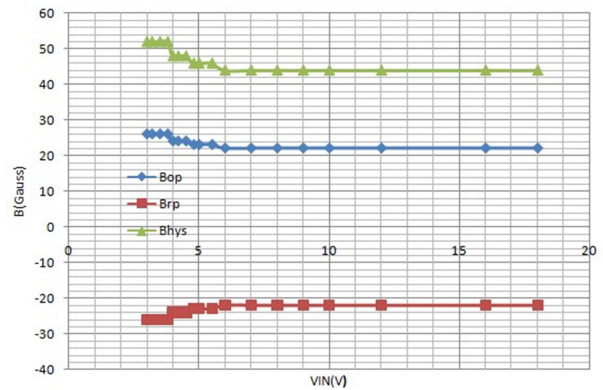

B_{OP}&B_{RP} vs. V_{IN}

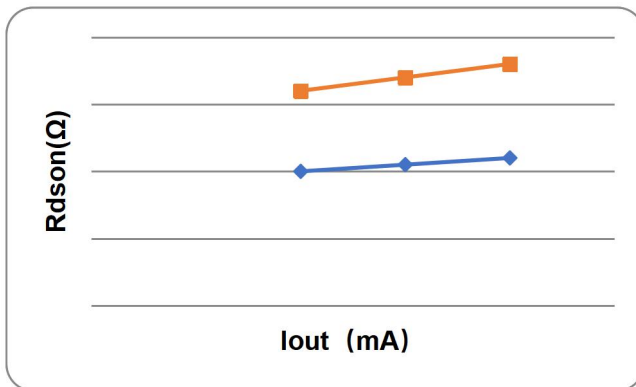

R_{DS(on)} vs. I_{OUT}

Typical Application Waveform

The product has built-in blocking protection. When the fan is blocked, the blocking protection function will turn off the fan coil current and try to restart every 2 seconds. The cycle of the switch reduces the average current to 1 / 7 of the normal blocking, which is enough to protect the fan from overheating and damage.

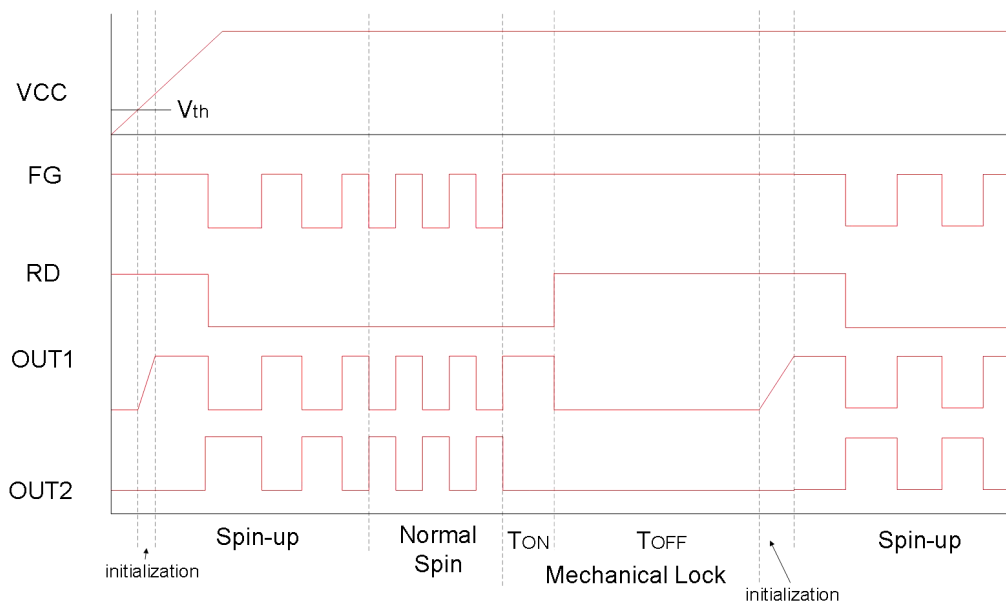

Note: After initialization, the RD signal is pulled down after the first OUT waveform is reversed.

Keep Locked Rotor Waveform

The waveform on the keep locked rotor is shown in the figure below. The states of DO and DOB may be interchanged, depending on whether the magnetic field on the chip surface is the south pole or the north pole. The magnetic field on the chip surface corresponding to the state of the picture below is the North Pole.

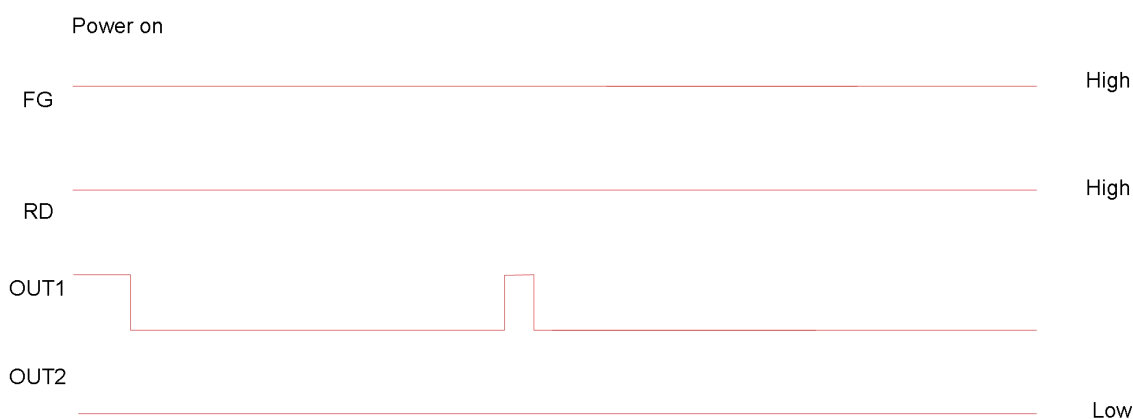

Power Dissipation & Maximum Output Current

The power dissipation is determined by the following equation (Note: K is the recommended coefficient):

$$P_{D(MAX)} = (T_J - T_A) / \theta_J \times K$$

While normal operation, the power dissipated in CC6410/1:

$$P = I_{CONT}^2 \times R_{DS(ON)} + V_{DD} \times I_{DD}$$

The maximum output current I_{MAX} :

$$I_{MAX} = \sqrt{(P_{D(MAX)} - V_{DD} \times I_{DD}) / R_{DS(ON)}}$$

The PD curve and the output current curve

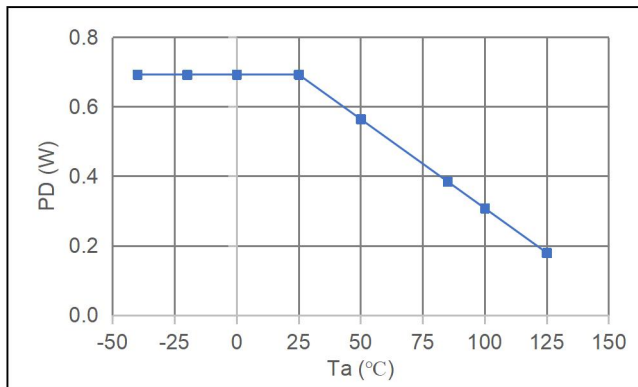

Power Dissipation of SOT335

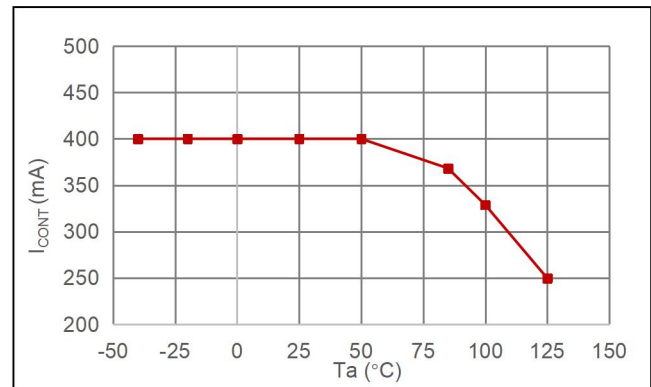

Maximum Output Current SOT335

Package Information

(1) SOT335 package

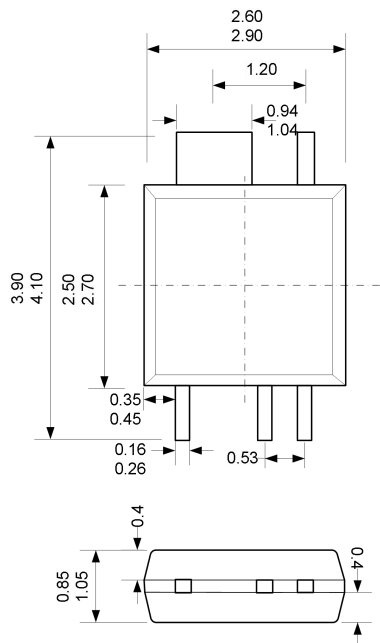

Note:

1. All dimensions are millimeters

Back Marking:

1'st line: 6410/1– product name

2'nd line: YYWW

YY – last 2 digits of year

WW – week

Hall location

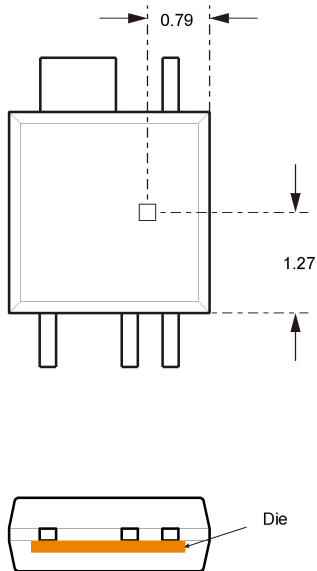

Note:

1. All dimensions are millimeters

Information of carrier tape

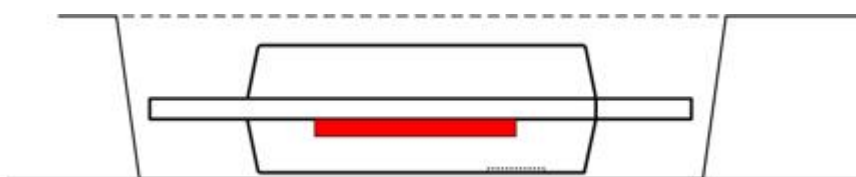

Packaging & Tape reel

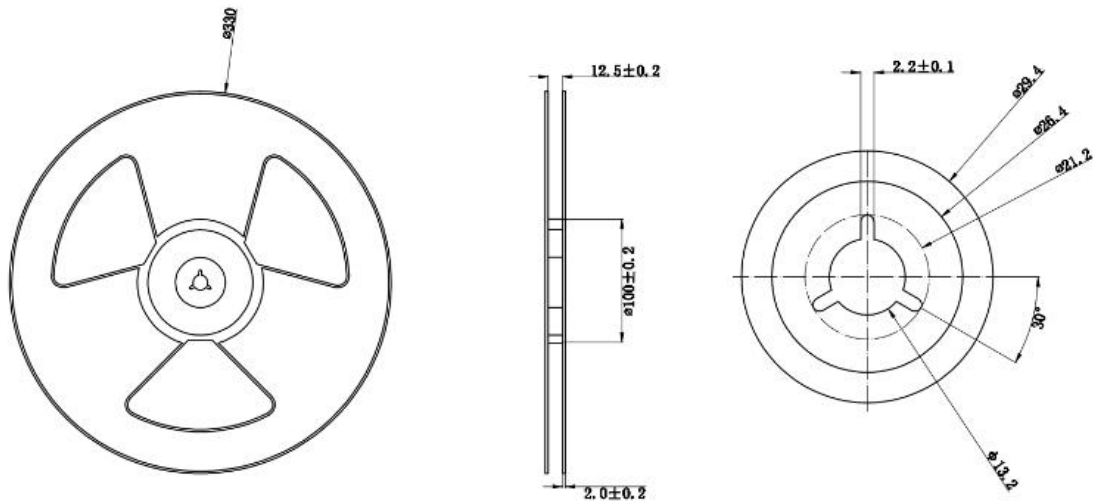

Information of Reel size

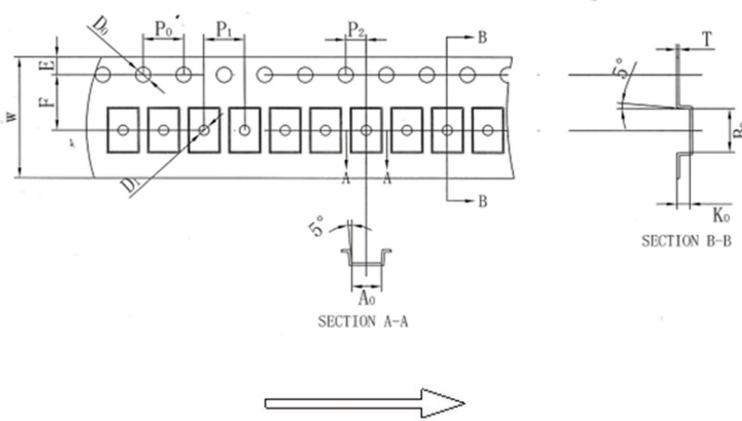

User Direction of Feed

Note: Each plate has 100 ± 5 grids in front of the tape and 100 ± 5 in the tail

Symbol	Millimeters		
	Min	Typical	Max
W	11.90	12.00	12.05
A0	2.90	2.95-	3.00
B0	4.30	4.35	4.40
K0	1.30	1.35	1.40
E	1.65	1.75	1.85
F	5.40	5.50	5.60
D1	-	1.00	1.10
D0	-	1.50	1.60
P0	3.90	4.00	4.10
P1	3.90	4.00	4.10
P2	1.95	2.00	2.05
t	0.20	0.25	0.30

Note:

1. All dimensions are millimeters

CrossChip

CrossChip Microsystems Inc. was founded in 2013, is a high-tech enterprise, engaged in integrated circuit design and sales. The company has strong technical strength, has more than 50 patents, mainly used in Hall sensor signal processing, with the following product lines:

- ✓ High precision linear Hall sensor
- ✓ All kinds of Hall switches
- ✓ Single phase motor drive
- ✓ Single chip current sensor
- ✓ AMR Magnetoresistance sensor

Contact us

Chengdu

Address: 4th floor, unit 2, building 3, No. 88, Tianchen Road, Gaoxinxi Zone, Chengdu, Sichuan Province

Tel: + 86 - 28 - 87787685

Email: support@crosschipmicro.com

Website: <http://www.crosschipmicro.com>

Shenzhen

Address: 605 room, 6F, Beike building, NO.18 Keyuan Rd, Yuehai Street, Nanshan District, Shenzhen

Shanghai

Address: Makeblock, 3 / F, magic square community, 4476 Huyi Road, Jiading District, Shanghai

