

MS-162B Series

# Compact Interface Coaxial Switch



Coax Switch



Compact



RF

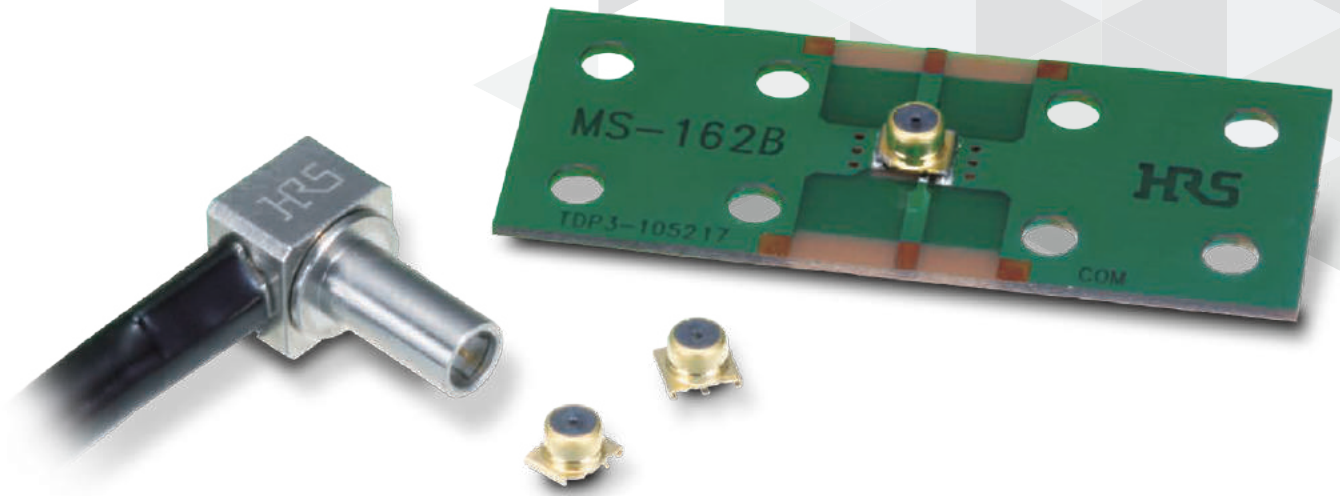

## Overview

The MS-162B Series is a coaxial switch for cellphone interfaces. It can also be used for circuit testing on microwave boards (DC to 10GHz). When the plug is not mated, the common contact and board circuit (NC) connect to form a circuit. The vertical type is used for mobile devices and can be installed near the antenna for output inspection, switching to an external antenna, etc.

## Features

### 1. Wide Frequency Range (DC to 10GHz)

Frequency range from DC to 10GHz.

### 2. Low Insertion Loss

When Unmated

DC-2GHz 0.2dB Max.

2-3GHz 0.3dB Max.

3-6GHz 0.5dB Max.

6-10GHz 0.7dB Max.

### 3. Space-saving, Low Profile

Size : 3.5mmx3.5mm (nominal)

Height : 2.5mm Max.

Weight : 0.043g

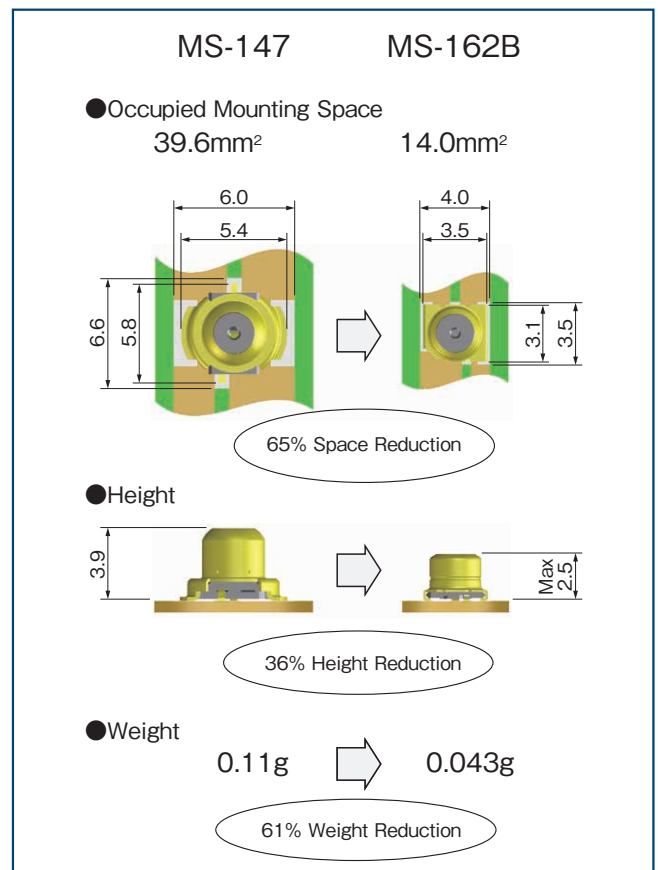

## 4. Long Product Life

The number of guaranteed mating cycles is 12,000 cycles.

## 5. Pick & Place Mounting

Tape-and-reel packaging for compatibility with automatic mounting.

## 6. Self-Alignment

The self-alignment range of the plug during mating is  $\pm 0.5$ mm.

## 7. Beryllium, Halogen-free

All materials and substances used to produce this receptacle comply with Halogen and Beryllium-free standards.

\*As defined by IEC61249-2-21

Br-900 ppm maximum, Cl-900 ppm maximum,  
Cl+Br combined-1,500 ppm maximum.

## Product Specifications

Items	Normally Closed	Normally Open
Operating Temperature	-40 to +85°C	
Rated Voltage	4W	
Frequency	DC-10 GHz	
Voltage Standing Wave Ratio	1.2 Max. (DC-3GHz) 1.5 Max. (3-6GHz) 1.7 Max. (6-10GHz)	1.2 Max. (DC-3GHz) 1.6 Max. (3-6GHz) 1.7 Max. (6-10GHz)
Insertion Loss	0.15 dB Max. (DC-2GHz) 0.2 dB Max. (2-3GHz) 0.4 dB Max. (3-6GHz) 0.7 dB Max. (6-10GHz)	0.2 dB Max. (DC-2GHz) 0.3 dB Max. (2-3GHz) 0.5 dB Max. (3-6GHz) 0.7 dB Max. (6-10GHz)
Isolation Loss	-	25 dB Min. (DC-1GHz) 20 dB Min. (1-3GHz) 14 dB Min. (3-6GHz) 12 dB Min. (6-10GHz)

Item	Standard	Conditions
Contact Resistance	100m Ω Max.	Measured at 100mA Max.
Insulation Resistance	1000M Ω Min.	Measured at 100V DC
Withstanding Voltage	No flashover or insulation breakdown	100V AC for 1 min.
Vibration Resistance	No electrical discontinuity of 1 μs or more	Frequency 10-55Hz, Single Amplitude 0.75mm, 10 cycles in 3 directions, total 30 cycles
Shock Resistance	No electrical discontinuity of 1 μs or more	Acceleration of 490m/s <sup>2</sup> , Half -sine Wave, 3 Directions, 3 times, 18 times total
Temperature Cycles	Contact Resistance : 100m Ω Max. Insulation Resistance : 10M Ω Min.	Temperature : -55 → +15 to +35 → +85 → +15 to +35°C Time : 30 → 2 to 3 → 30 → 2 to 3(Min.) 100 cycles
Heat Resistance	Contact Resistance : 100m Ω Max. Insulation Resistance : 10M Ω Min.	Left for 96 hours at 85°C
Cold Resistance	Contact Resistance : 100m Ω Max. Insulation Resistance : 10M Ω Min.	Left for 96 hours at -55°C
Humidity Resistance	Contact Resistance : 100m Ω Max. Insulation Resistance : 10M Ω Min.	Left for 96 hours at 40°C and 90 to 95% RH
Mating Durability	Contact Resistance : 100m Ω Max.	12,000 cycles

## Materials/Finish

Component	Materials	Finish	UL Standard
Shell	Brass	Gold Plated	-
Insulator	LCP	-	UL94V-0
Common Contact	Copper Alloy	Partially Gold Plated	-
Antenna Contact	Phosphor Bronze	Partially Gold Plated	-

## High Frequency Performance (Typical)

### ● Normally Closed (Unmated)

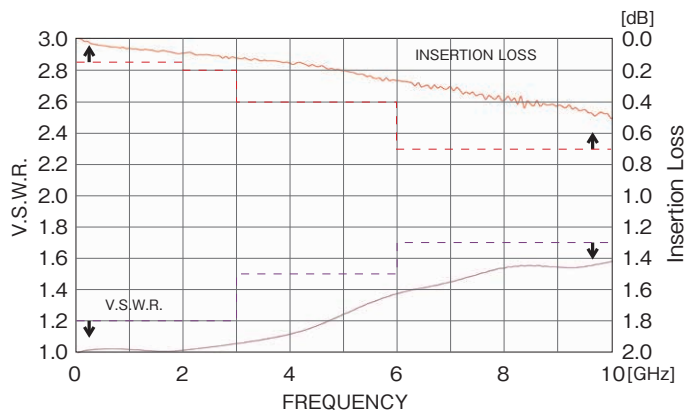

### ● Normally Open (Mated)

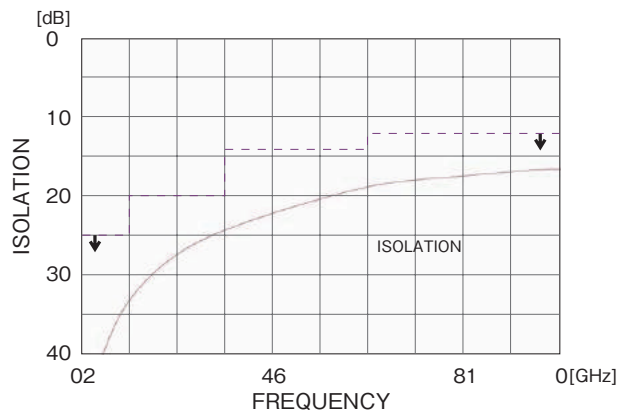
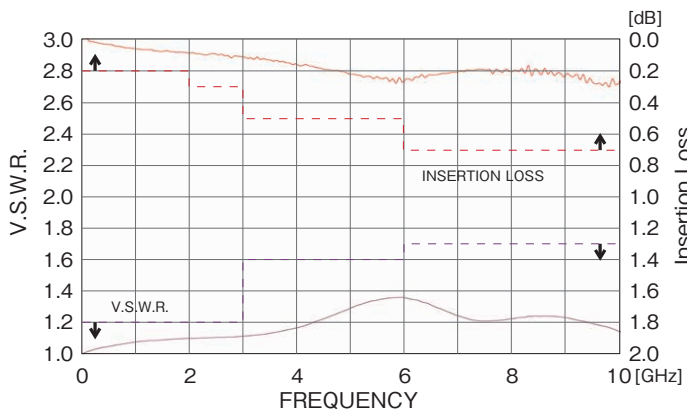

# Receptacle

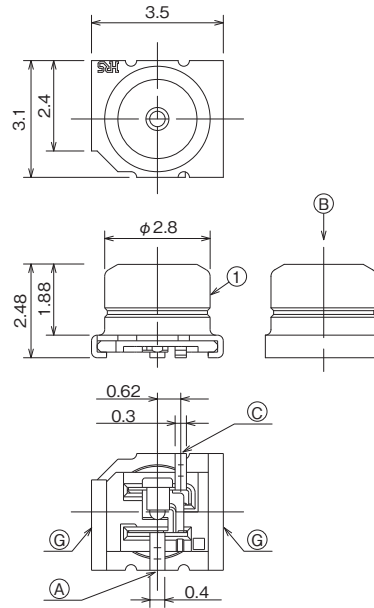

## ● Circuit Diagram

[Not Mated with Plug]

[Mated with Plug]

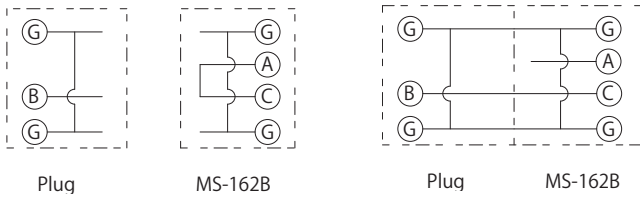

## ● Specified Land Pattern Dimensions

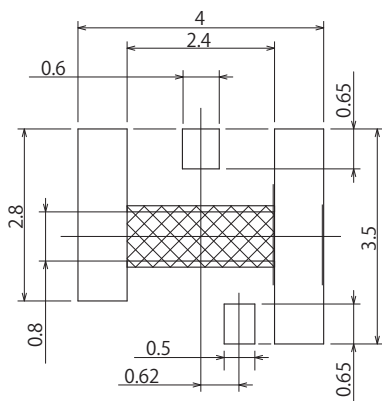

This area should be covered with resist pattern.

## ● Specified Metal Mask Dimensions

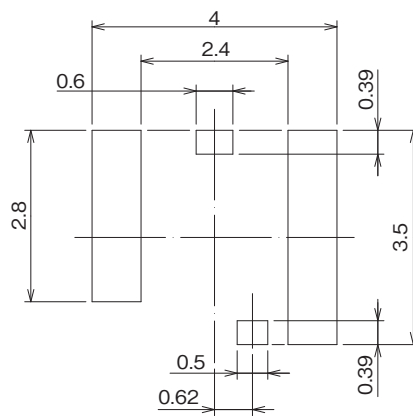

Note : Specified Metal Mask Thickness  $t=0.12\text{mm}$

Part No.	HRS No.	Purchase Unit
MS-162B	CL0358-0343-9-00	3,000pcs per reel

## Plug

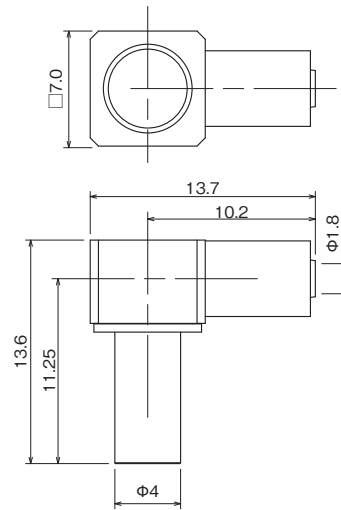
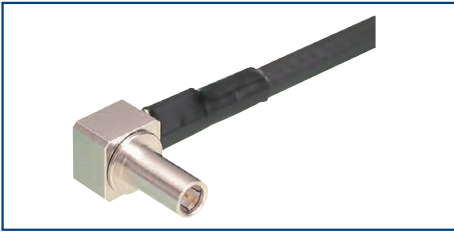

Part No.	HRS No.	Purchase Unit	Remarks
MS-162-C(LP)-1	CL0358-0222-4-00	20pcs per bag	Cable Assembly Compatible L-shaped Type

Note : Applicable Cable : 1.5D-HQEW, 1.5D-QEW (Fujikura Ltd.)

Cable Termination Tool : For Outer Conductor: HT3030/PO-P-2-T, Cover Setting Tool: UM-T-1

## SMA Conversion Adapter

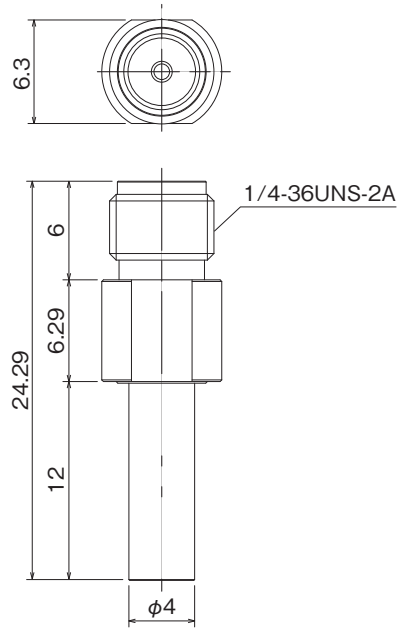
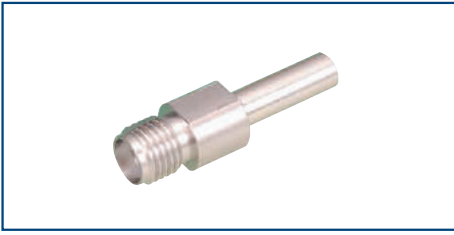

Part No.	HRS No.	Friction Lock	Purchase Unit	Remarks
MS-162-HRMJ-1	CL0358-0210-5-00	—	50pcs per tray	MS-162B to SMA Jack Conversion Adapter
MS-162-HRMJ-H1	CL0358-0221-1-00	○		

## Packaging Specifications

IEC 60286-3 / JIS C 0806 Compliant

### Receptacle

#### ● Embossed Carrier Tape Dimensions

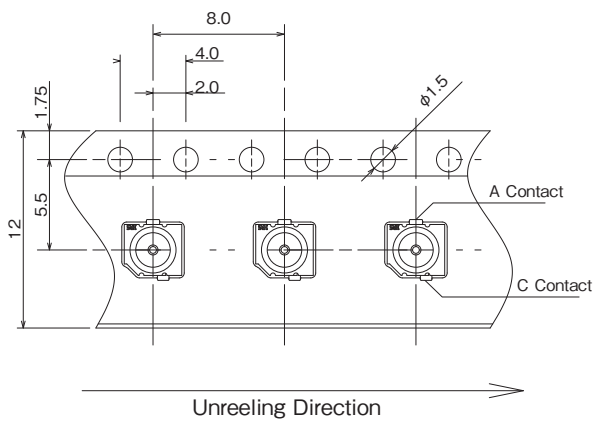

#### ● Reel Dimensions

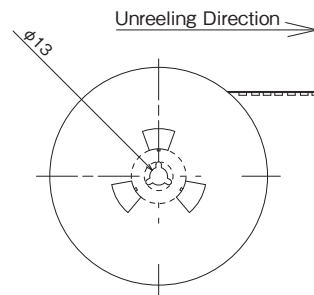



## Recommended Temperature Profile

### ● Lead-free Solder Temperature Profile

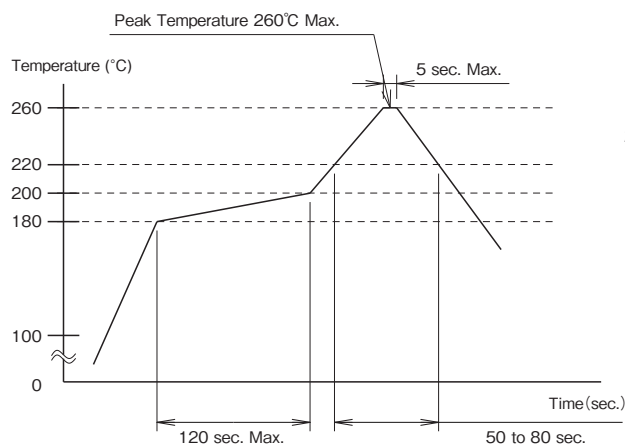

[Conditions]

Maximum Temperature : 260°C Max.  
 Peak Temperature Time : 5 sec. Max.  
 Peak Temperature : 240 to 255°C  
 220°C Min : 50 to 80 sec.  
 180 to 200°C : 120 sec. Max.

## Recommended Nozzle Dimensions

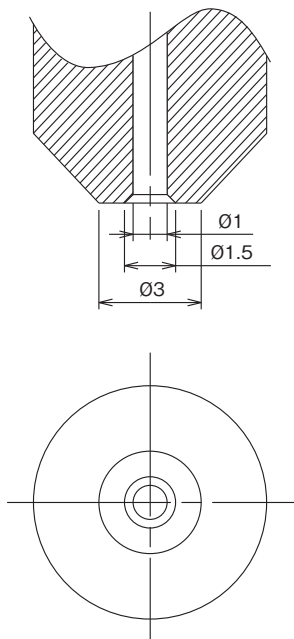

## Application Example

### ● Used as Interface

Note : This figure shows an example of mounting. Please provide a floating design or design that presses by spring. After plug mating the total load ① should be 10 to 15N.

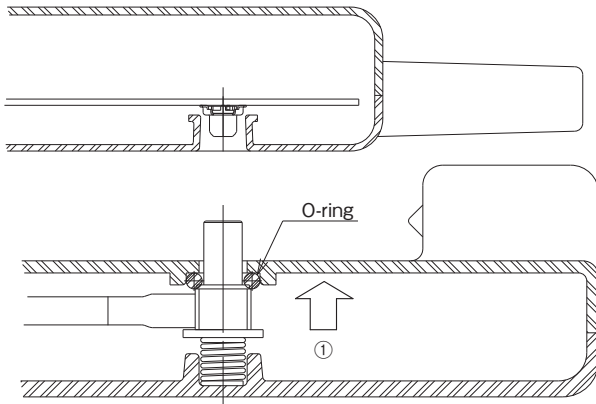

### ● Usage in Testing Fixture

Note : This figure shows an example of mounting. Please provide a floating design or design that presses by spring. After plug mating the total load ① should be 10 to 15N.

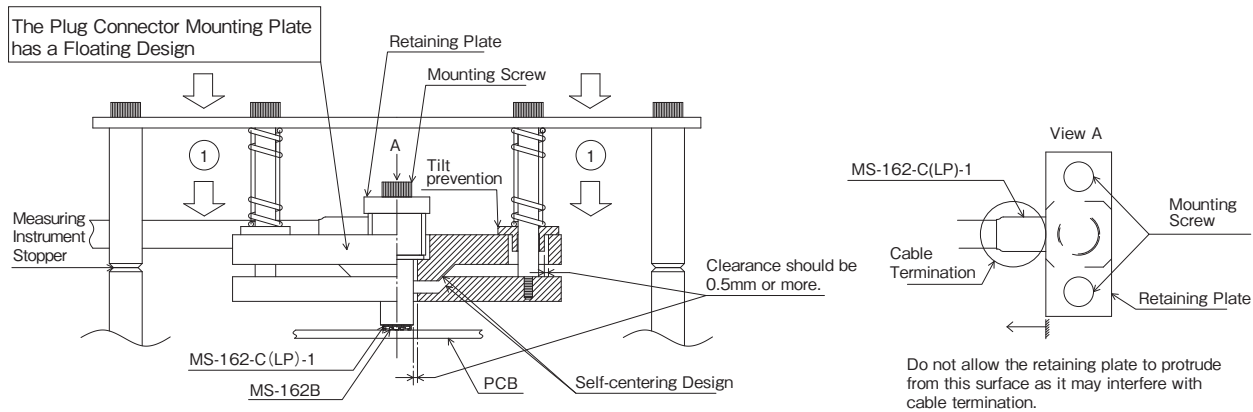

### [Self-Alignment Range and Angle During Mating]

Note : This is the self-alignment range until it is guided by the receptacle and the tapered portion of the plug. During mating, a floating mechanism is needed to push the plug vertically using springs.

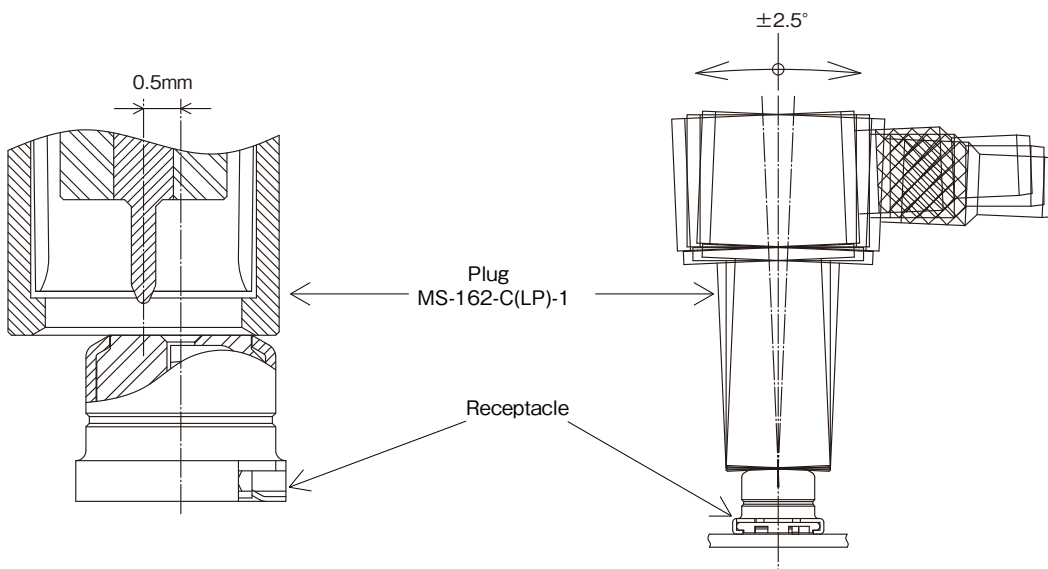

## Precautions

1. This product cannot be washed.
2. During design, make sure that the product will not be subjected to force from the panel when dropped while mounted to the board.
3. Do not mount with manual solder. There is a risk of solder flux and wicking in the contact areas.
4. When using a heat gun, hot plate, etc., please keep use within 10 seconds at 260°C or less. If usage exceeds the above conditions, the plastic may melt and deform.
5. Refrain from using land patterns or metal mask dimensions other than those specified by Hirose as it may result in solder flux and wicking that may result in product failure.
6. Refrain from using this product in environments of dust, high humidity, gas, extremely high and low temperatures.
7. When using this product as an RF interface for mobile devices, secure a rubber cap to prevent dust from entering when the plug is not mated.
8. Before use make sure the plug is fully inserted to the (P) surface as shown below.

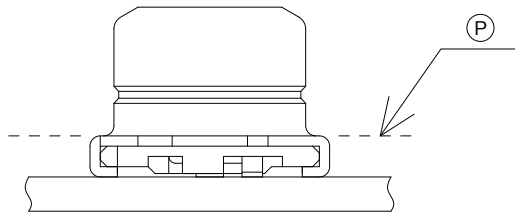

## While Taking into Consideration

Specifications mentioned in this catalog are reference values.

When considering to order or use this product, please confirm the Drawing and Product Specifications sheets.

Use an appropriate cable when using the connector in combination with cables.

If considering usage of a non-specified cable, please contact your sales representative.

If assembly process is done by jigs & tools which are not identified by Hirose, assurance will not be given.

If considering usage for below mentioned applications, please contact your sales representative.

In cases where the application will demand a high level of reliability, such as automotive, medical instruments, public infrastructure, aerospace/ defense etc. Hirose must review before assurance of reliability can be given.