

## FH65 Series

# 0.5mm Pitch, Height 1.2mm, Bottom Contact, Front Flip, 125°C Compatible, FPC/FFC Connector

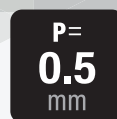

TM Flip-Lock Pioneer Hirose



P= 0.5mm



Heat-Resist



Front Flip

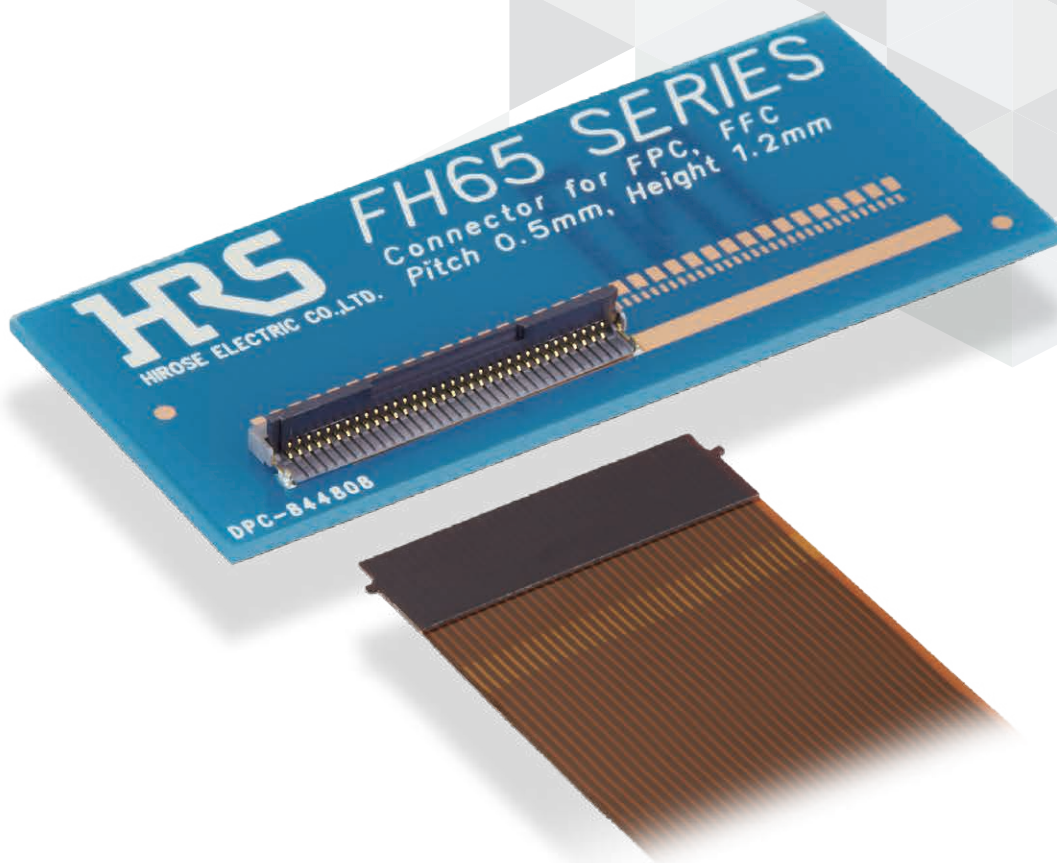

## Features

### 1. Heat Resistant up to 125°C

FH65 withstands heat up to 125°C, making it ideal for applications requiring heat resistance such as automotive equipment.

### 2. Low Profile, Space-Saving Design

Space-saving with 1.2mm height and 3.57mm depth.

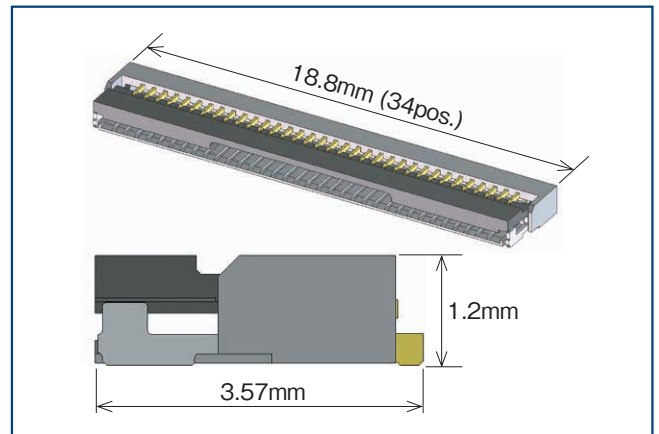

### 3. Satisfies severe requirements for various automotive applications

This space-saving design satisfies severe requirements for various automotive applications. (Ex. Temperature cycles)

Temperature

-55 → +15 to +35 → +125 → +15 to +35°C

Time

30 → 2 to 3 → 30 → 2 to 3 minutes

1,000 cycles under the above conditions

### 4. Flip-lock enables excellent workability

The flip-lock (one-touch rotation) ZIF design enables easy and reliable FPC/FFC connection.

In addition, the firm and clear tactile click prevents incomplete locking.

## 5. High FPC/FFC Retention Force

The tabbed FPC/FFC provides a high FPC/FFC retention force in the horizontal direction.

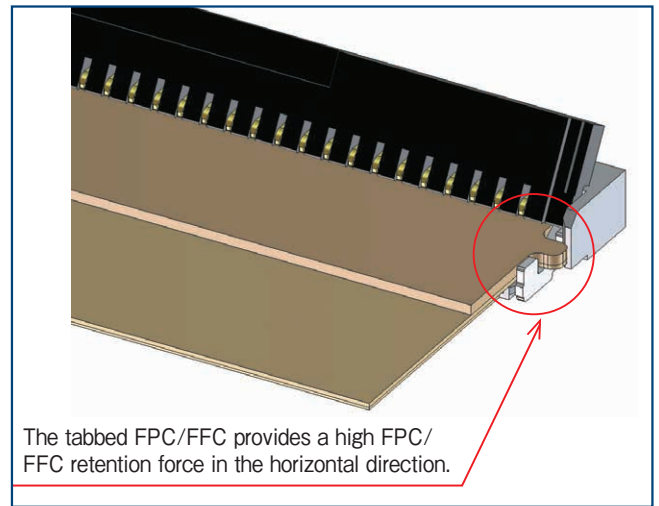

Connection using the FPC/FFC temporary holding mechanism

## 6. FPC/FFC can be inserted easily.

The FPC/FFC positioning mechanism enables the FPC/FFC to be temporarily held in place in the correct mating position.

## 7. Easy visual inspection after mating FPC/FFC

Easy to visually check if FPC/FFC is correctly mated by the FPC/FFC positioning mechanism.

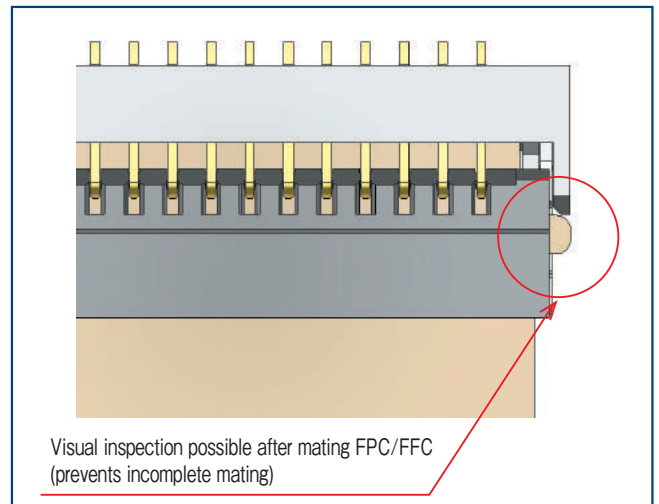

## 8. Supports 0.3mm FPC/FFC thickness

Supports the thickness of 0.3mm, which eases manufacturing and insertion.

## 9. Environmental Compatibility

No chlorine or bromine exceeding the standard values are used in this connector.

As defined by IEC 61249-2-21.

Br : 900ppm Max., Cl : 900ppm Max.,

Br+Cl : 1,500ppm Max.

## Product Specifications

Rated Current	0.5A	Operating Temperature (Note 1)	-40 to +125°C
Rated Voltage	50V AC/DC	Storage Temperature Range (Note 2)	-10 to +50°C

Operating Humidity Range	Relative humidity 90% RH or less (no condensation)	Storage Humidity Range	Relative humidity 90% RH or less (no condensation)
--------------------------	--	------------------------	--

Recommended FPC/FFC SPC	t=0.3 ± 0.05 Gold plated 125°C resistant FPC/FFC
-------------------------	--

Items	Specifications	Conditions
Insulation Resistance	500M Ω Min.	100V DC
Withstanding Voltage	No flashover or insulation breakdown	150V AC
Contact Resistance	50m Ω Max. *Including FPC conductor resistance	1mA AC
Mating Durability	Contact resistance : 50m Ω Max. No damages, cracks and looseness of parts	20 times
Vibration Resistance	No electrical discontinuity of 1 μ s or longer Contact resistance : 50m Ω Max. No damages, cracks and looseness of parts	Frequency : 10 to 55Hz, half amplitude : 0.75mm, for 10 cycles in 3 axial directions.
Shock Resistance	No electrical discontinuity of 1 μ s or longer Contact resistance : 50m Ω Max. No damages, cracks and looseness of parts	Acceleration : 981m/s <sup>2</sup> , duration 6ms, half-sine wave, at 3 times in 3 axial directions
High Temperature and High Humidity Environment	Contact resistance : 50m Ω Max. Insulation resistance : 50M Ω Min. No damages, cracks and looseness of parts	1000 hours at +85°C and humidity of 90 to 95%
Temperature Cycles	Contact resistance : 50m Ω Max. Insulation resistance : 50M Ω Min. No damages, cracks and looseness of parts	Temperature : -55 → +15 to +35 → +125 → +15 to +35°C Time : 30 → 2 to 3 → 30 → 2 to 3 minutes 1000 cycles with above conditions
Resistance to Soldering Heat	No deformation of case or excessive looseness of the contacts	Reflow : See recommended temperature profile Manual soldering : +400 ± 10°C , 5 seconds

Note 1 : Includes temperature rise due to current flow.

Note 2 : The term "storage" refers to the long-term storage condition of unused products before PCB mounting.

The operating temperature and humidity are applicable after PCB mounting when the product is not energized.

## Materials / Finish

Parts	Material	Finish	UL Regulation
Insulator	LCP	Gray	UL94V-0
	PPS	Black	UL94V-0
Contact	Coper Alloy	Nickel Barrier Gold Plating	-
Retention Tab	Brass	Pure Tin Reflow Glating	-

## Product Number Structure

Refer to the chart below when determining the product specifications from the product number.  
Please select from the product numbers listed in this catalog when placing orders.

### **FH65 - 34S - 0.5 SH (##)**

①                      ②                      ③                      ④                      ⑤

① Series Name	FH65	④ Terminal Type	SH : SMT Horizontal Mounting Type
② No.of Pos.	8, 10, 15, 34	⑤ Specifications	None : Standard (5,000pcs/reel) (99) : 500pcs/reel (For trial production)
③ Contact Pitch	0.5mm		

## Connector Dimensions

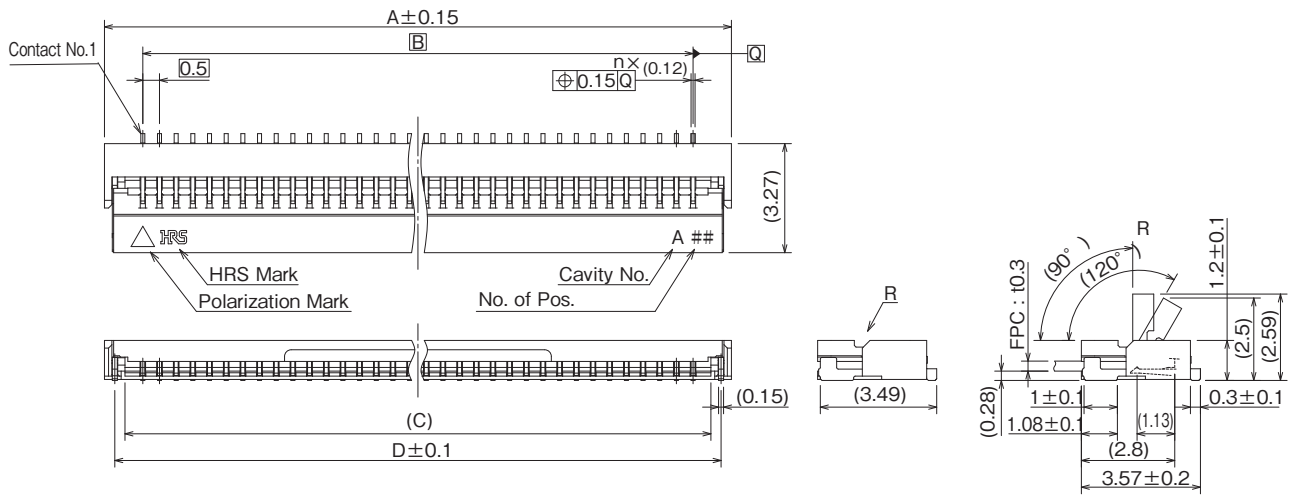

- Note 1 : The dimensions in parentheses are for reference.  
 Note 2 : Lead co-planarity including solder tab leads shall be 0.1mm Max.  
 Note 3 : Delivered with tape and reel packages. See the packaging specifications for details.  
 Note 4 : Note that a preventive hole for sink mark or slit could be added for improvement.  
 Note 5 : Black spots may appear on the resin but this does not affect product performance.  
 Note 6 : This product satisfies halogen free requirements defined as below.  
 900ppm maximum chlorine, 900ppm maximum bromine, and 1500ppm maximum total of chlorine and bromine.  
 Note 7 : 'n' represents the number of contacts.

Unit : mm

Part No.	HRS No.	No. of Pos.	A	B	C	D	Purchase Unit (##) : None	Purchase Unit (##) : 99
FH65-4S-0.5SH(##)	Under Planning (Note)	4	3.8	1.5	2.57	3.18	-	-
FH65-6S-0.5SH(##)	Under Planning (Note)	6	4.8	2.5	3.57	4.18	-	-
FH65-8S-0.5SH(##)	CL0580-4703-0-##	8	5.8	3.5	4.57	5.18	5,000 per reel	500 per reel
FH65-10S-0.5SH(##)	CL0580-4704-0-##	10	6.8	4.5	5.57	6.18		-
FH65-12S-0.5SH(##)	CL0580-4708-0-##	12	7.8	5.5	6.57	7.18		-
FH65-14S-0.5SH(##)	Under Planning (Note)	14	8.8	6.5	7.57	8.18	-	-
FH65-15S-0.5SH(##)	CL0580-4701-0-##	15	9.3	7.0	8.07	8.68	5,000 per reel	500 per reel
FH65-16S-0.5SH(##)	Under Planning (Note)	16	9.8	7.5	8.57	9.18	-	-
FH65-18S-0.5SH(##)	Under Planning (Note)	18	10.8	8.5	9.57	10.18	-	-
FH65-20S-0.5SH(##)	Under Planning (Note)	20	11.8	9.5	10.57	11.18	-	-
FH65-22S-0.5SH(##)	Under Planning (Note)	22	12.8	10.5	11.57	12.18	-	-
FH65-24S-0.5SH(##)	Under Planning (Note)	24	13.8	11.5	12.57	13.18	-	-
FH65-26S-0.5SH(##)	Under Planning (Note)	26	14.8	12.5	13.57	14.18	-	-
FH65-28S-0.5SH(##)	Under Planning (Note)	28	15.8	13.5	14.57	15.18	-	-
FH65-30S-0.5SH(##)	Under Planning (Note)	30	16.8	14.5	15.57	16.18	-	-
FH65-32S-0.5SH(##)	Under Planning (Note)	32	17.8	15.5	16.57	17.18	-	-
FH65-34S-0.5SH(##)	CL0580-4700-0-##	34	18.8	16.5	17.57	18.18	5,000 per reel	500 per reel
FH65-36S-0.5SH(##)	Under Planning (Note)	36	19.8	17.5	18.57	19.18	-	-
FH65-40S-0.5SH(##)	Under Planning (Note)	40	21.8	19.5	20.57	21.18	-	-
FH65-45S-0.5SH(##)	Under Planning (Note)	45	24.3	22.0	23.07	23.68	-	-

Note : Contact positions without HRS No. are currently under planning.  
Please contact a Hirose representative for detailed information about product variations.

### Recommended PCB Mounting Pattern

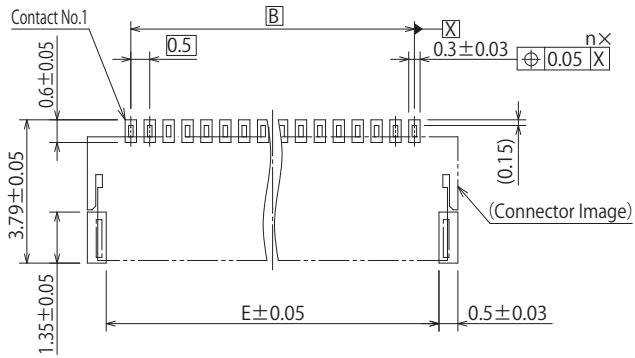

### Recommended Metal Mask Dimensions

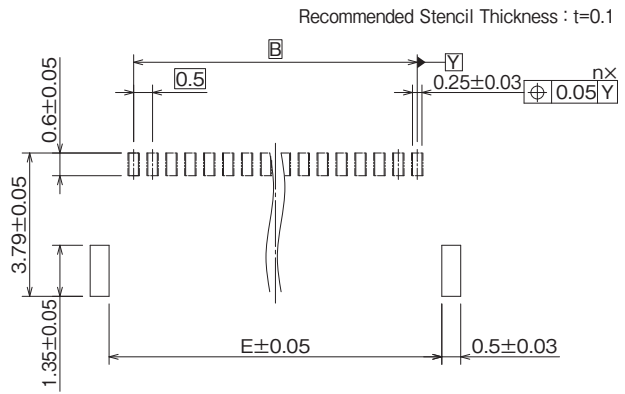

### Recommended FPC/FFC Dimensions

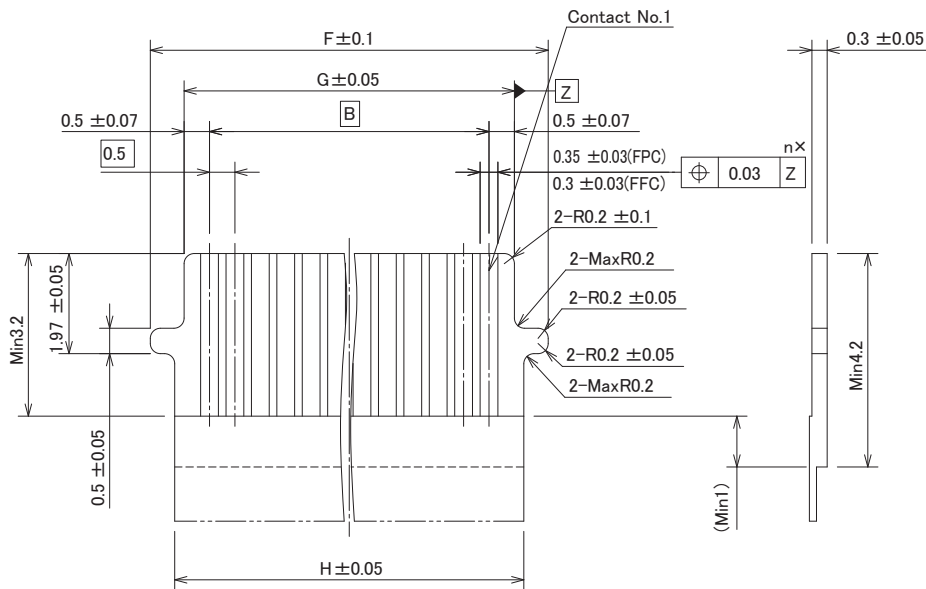



Unit : mm

Part No.	HRS No.	No. of Pos.	B	E	F	G	H
FH65-4S-0.5SH(##)	Under Planning (Note)	4	1.5	2.8	3.83	2.5	2.87
FH65-6S-0.5SH(##)	Under Planning (Note)	6	2.5	3.8	4.83	3.5	3.87
FH65-8S-0.5SH(##)	CL0580-4703-0-##	8	3.5	4.8	5.83	4.5	4.87
FH65-10S-0.5SH(##)	CL0580-4704-0-##	10	4.5	5.8	6.83	5.5	5.87
FH65-12S-0.5SH(##)	CL0580-4708-0-##	12	5.5	6.8	7.83	6.5	6.87
FH65-14S-0.5SH(##)	Under Planning (Note)	14	6.5	7.8	8.83	7.5	7.87
FH65-15S-0.5SH(##)	CL0580-4701-0-##	15	7.0	8.3	9.33	8.0	8.37
FH65-16S-0.5SH(##)	Under Planning (Note)	16	7.5	8.8	9.83	8.5	8.87
FH65-18S-0.5SH(##)	Under Planning (Note)	18	8.5	9.8	10.83	9.5	9.87
FH65-20S-0.5SH(##)	Under Planning (Note)	20	9.5	10.8	11.83	10.5	10.87
FH65-22S-0.5SH(##)	Under Planning (Note)	22	10.5	11.8	12.83	11.5	11.87
FH65-24S-0.5SH(##)	Under Planning (Note)	24	11.5	12.8	13.83	12.5	12.87
FH65-26S-0.5SH(##)	Under Planning (Note)	26	12.5	13.8	14.83	13.5	13.87
FH65-28S-0.5SH(##)	Under Planning (Note)	28	13.5	14.8	15.83	14.5	14.87
FH65-30S-0.5SH(##)	Under Planning (Note)	30	14.5	15.8	16.83	15.5	15.87
FH65-32S-0.5SH(##)	Under Planning (Note)	32	15.5	16.8	17.83	16.5	16.87
FH65-34S-0.5SH(##)	CL0580-4700-0-##	34	16.5	17.8	18.83	17.5	17.87
FH65-36S-0.5SH(##)	Under Planning (Note)	36	17.5	18.8	19.83	18.5	18.87
FH65-40S-0.5SH(##)	Under Planning (Note)	40	19.5	20.8	21.83	20.5	20.87
FH65-45S-0.5SH(##)	Under Planning (Note)	45	22.0	23.3	24.33	23.0	23.37

Note : Contact positions without HRS No. are currently under planning.  
Please contact a Hirose representative for detailed information about product variations.

## Packaging Specifications

### ● Embossed Carrier Tape Dimensions

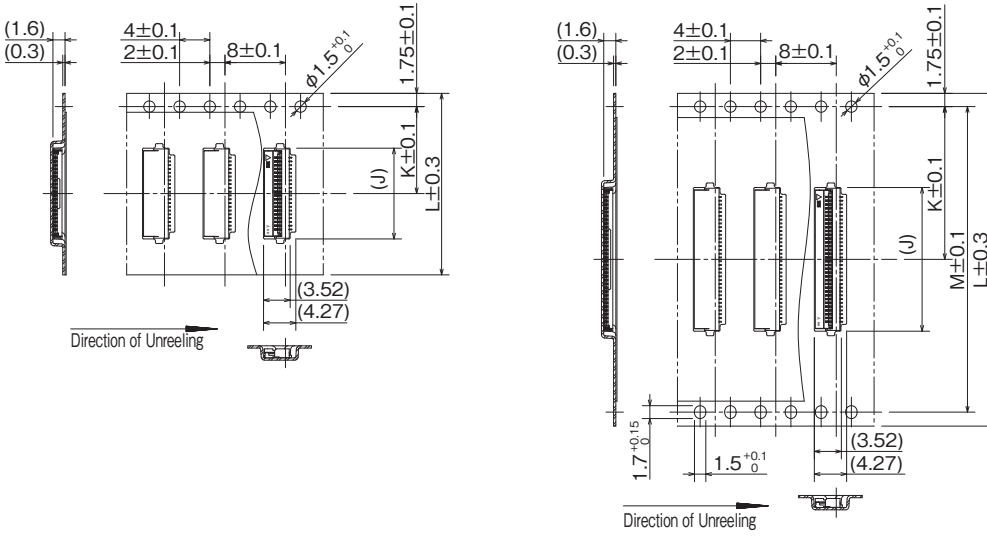

### ● Reel Dimensions

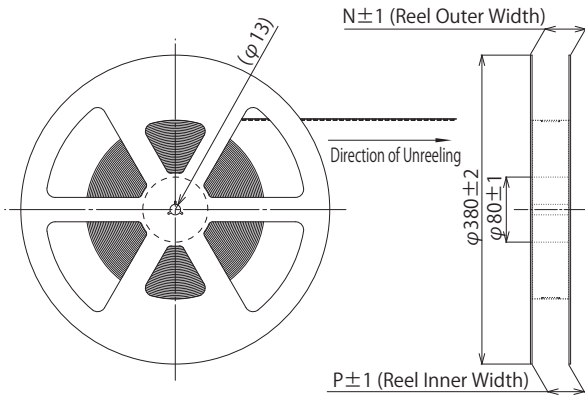

### ● Leader, Trailer Dimensions

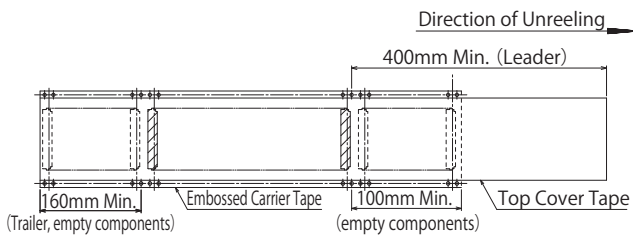

Unit : mm

H	HRS No.	No. of Pos.	J	K	L	M	N	P
FH65-4S-0.5SH(##)	Under Planning (Note)	4	4.0	7.5	16.0	-	21.4	17.4
FH65-6S-0.5SH(##)	Under Planning (Note)	6	5.0	7.5	16.0	-	21.4	17.4
FH65-8S-0.5SH(##)	CL0580-4703-0-##	8	6.0	7.5	16.0	-	21.4	17.4
FH65-10S-0.5SH(##)	CL0580-4704-0-##	10	7.0	11.5	24.0	-	29.4	25.4
FH65-12S-0.5SH(##)	CL0580-4708-0-##	12	8.0	11.5	24.0	-	29.4	25.4
FH65-14S-0.5SH(##)	Under Planning (Note)	14	9.0	11.5	24.0	-	29.4	25.4
FH65-15S-0.5SH(##)	CL0580-4701-0-##	15	9.5	11.5	24.0	-	29.4	25.4
FH65-16S-0.5SH(##)	Under Planning (Note)	16	10.0	11.5	24.0	-	29.4	25.4
FH65-18S-0.5SH(##)	Under Planning (Note)	18	11.0	11.5	24.0	-	29.4	25.4
FH65-20S-0.5SH(##)	Under Planning (Note)	20	12.0	11.5	24.0	-	29.4	25.4
FH65-22S-0.5SH(##)	Under Planning (Note)	22	13.0	11.5	24.0	-	29.4	25.4
FH65-24S-0.5SH(##)	Under Planning (Note)	24	14.0	11.5	24.0	-	29.4	25.4
FH65-26S-0.5SH(##)	Under Planning (Note)	26	15.0	14.2	32.0	28.4	37.4	33.4
FH65-28S-0.5SH(##)	Under Planning (Note)	28	16.0	14.2	32.0	28.4	37.4	33.4
FH65-30S-0.5SH(##)	Under Planning (Note)	30	17.0	14.2	32.0	28.4	37.4	33.4
FH65-32S-0.5SH(##)	Under Planning (Note)	32	18.0	14.2	32.0	28.4	37.4	33.4
FH65-34S-0.5SH(##)	CL0580-4700-0-##	34	19.0	20.2	44.0	40.4	49.4	45.4
FH65-36S-0.5SH(##)	Under Planning (Note)	36	20.0	20.2	44.0	40.4	49.4	45.4
FH65-40S-0.5SH(##)	Under Planning (Note)	40	22.0	20.2	44.0	40.4	49.4	45.4
FH65-45S-0.5SH(##)	Under Planning (Note)	45	24.5	20.2	44.0	40.4	49.4	45.4

Note : Contact positions without HRS No. are currently under planning.

Please contact a Hirose sales representative for detailed information about product variations.

## FPC/FFC Construction (Recommended Specifications)

### 1. Using Single-Sided FPC (FPC : Flexible Printed Circuit)

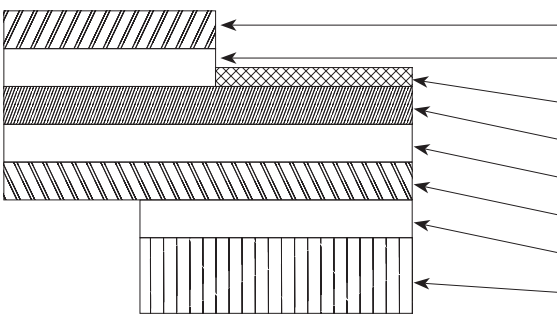

Material Name	Material	Thickness ( μm)
Covering film layer	Polyimide 1mil	(25)
Cover adhesive	1/2oz	(18)
Surface treatment	0.2 μm thick gold plated over 1 to 5 μm thick nickel underplating	3
Copper foil	Cu 1oz	35
Base adhesive	Thermosetting adhesive	25
Base film	Polyimide 1mil thick	25
Reinforcement material adhesive	Thermosetting adhesive	30
Stiffener	Polyimide 7mil thick	175
Total		293

### 2. Using Double-Sided FPC (FPC : Flexible Printed Circuit)

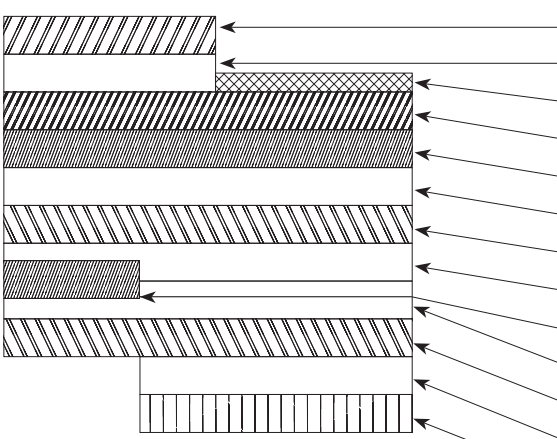

Material Name	Material	Thickness ( μm)
Covering film layer	Polyimide 1mil	(25)
Cover adhesive		(25)
Surface treatment	0.2 μm thick gold plated over 1 to 5 μm thick nickel underplating	3
Through-hole copper	Cu	15
Copper foil	Cu 1/2oz	18
Base adhesive	Thermosetting adhesive	18
Base film	Polyimide 1mil thick	25
Base adhesive	Thermosetting adhesive	18
Copper foil	Cu 1/2oz	(18)
Cover adhesive	Thermosetting adhesive	25
Covering layer film	Polyimide 1mil thick	25
Reinforcement material adhesive	Thermosetting adhesive	50
Stiffener	Polyimide 4mil thick	100
Total		297

Note : To prevent release of the FPC due to bending, use of double-sided FPC with copper foil on the back side is not recommended.

### 3. Using FFC (FFC : Flexible Flat Cable)

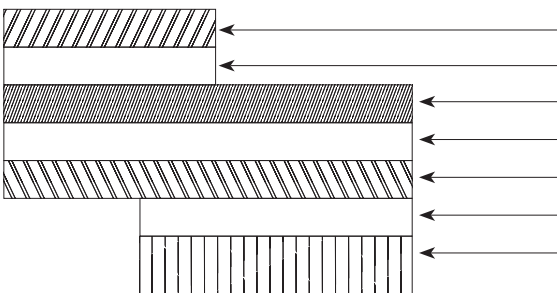

Material Name	Material	Thickness ( μm)
Polyester film		(12)
Adhesive	Thermoplastic polyester	(30)
Gold plated annealed copper foil		35
Adhesive	Polyester	30
Polyester		12
Adhesive	Polyester	30
Stiffener	Polyester	188
Total		295

Note : Typical thickness tolerance is about ± 20 μm

### 4. Precautions

1. This specification is a recommendation for the construction of the FH65 Series FPC and FFC (t = 0.3±0.05mm).
2. For details about the construction, please contact the FPC/FFC manufacturers.

## Temperature Profile

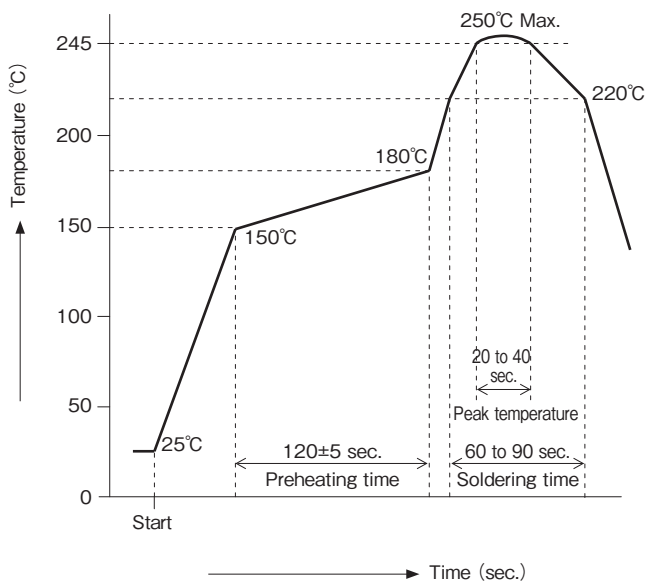

### Applicable Conditions

Reflow Method : IR/Hot air

Reflow Environment : Room air

Environment :

Solder : Paste type Sn/3.0Ag/0.5Cu (M705-GRN360-K2-V made by Senju Metal Industry Co.)

Test PCB : PCB material and size  
Glass epoxy 80 × 100 × 1.6mm  
Land size, per recommended PCB mounting pattern.

Metal Mask : Thickness and opening size per recommended Metal mask dimensions.

This temperature profile is based on the above conditions. It may vary depending on solder paste type, manufacturer, PCB size and mounting materials. Please use only after checking the mounting conditions.

## Operation Methods of Connectors and Precautions

### [Operation Method]

This connector requires delicate and careful handling due to its small design.

In order to prevent damage and contact failure etc. (incorrect mating, disconnection of FPC/FFC pattern) of connectors and FPC/FFC, please use them after following the below instructions.

The values described in the cautions vary from the product specifications.

### 1. Initially Delivered State

Actuator is locked in the delivered state.

### [Caution]

- Do not operate the connector while it is not mounted on the board.

**2. Actuator Lock Release Method (FPC/FFC not inserted)**

The actuator rotates at its center, as shown in the Figure below.  
Operate the actuator and slowly rotate it, releasing the lock. [Fig.1]

[Caution]

- Operate the actuator close to its center. [Fig.2]
- Do not operate the actuator only on one side. [Fig.3]
- Operate the actuator by hand, take care not to allow jigs or nails to get inside the connector. [Fig.4, Fig.5]
- Actuator cannot be opened wider than 120°. Do not force it to open wider than that angle. [Fig.6]
- Do not apply a strong force in the actuator slide direction. It could prevent the actuator from sliding in, as shown in the Figure. [Fig.7]
- Do not pick and raise the actuator or hook it. [Fig.8, Fig.9]

[Fig.1]

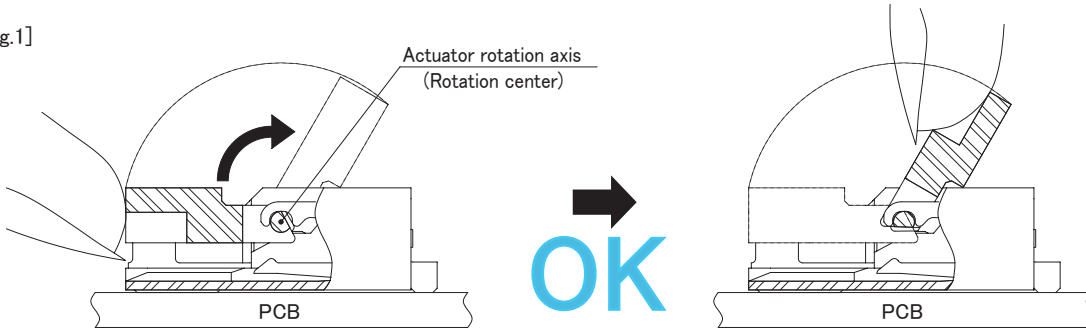

[Fig.2]

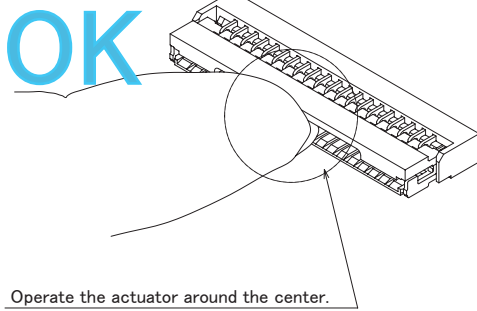

[Fig.3]

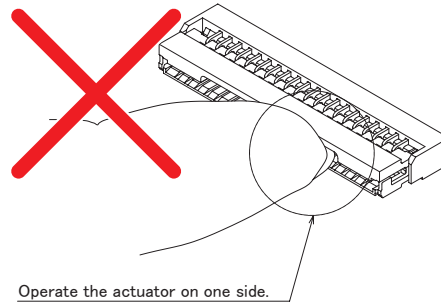

[Fig.4]

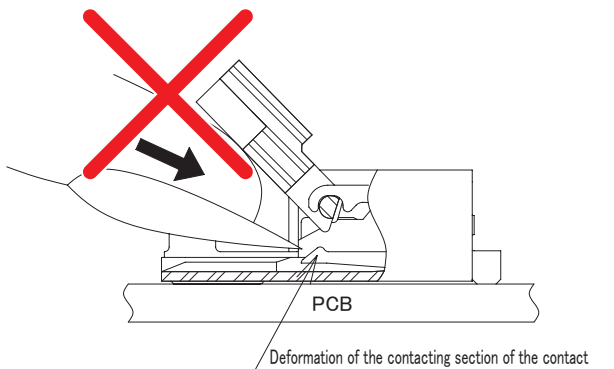

[Fig.5]

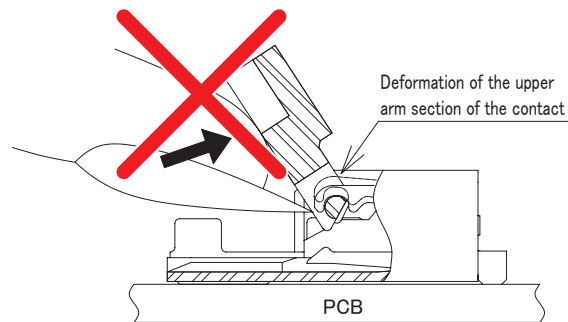

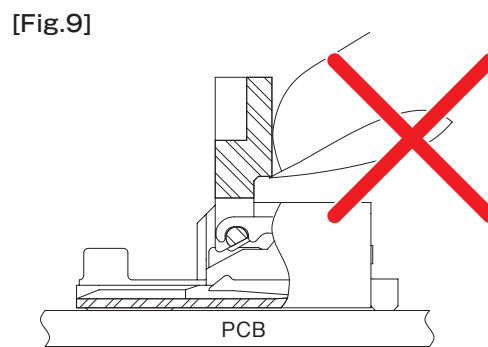
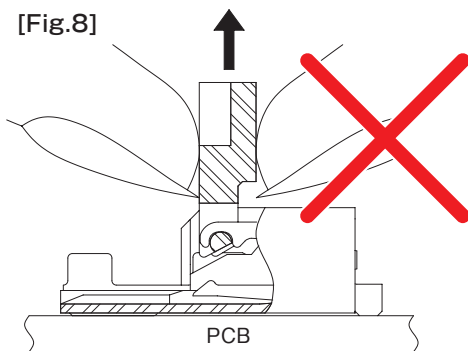
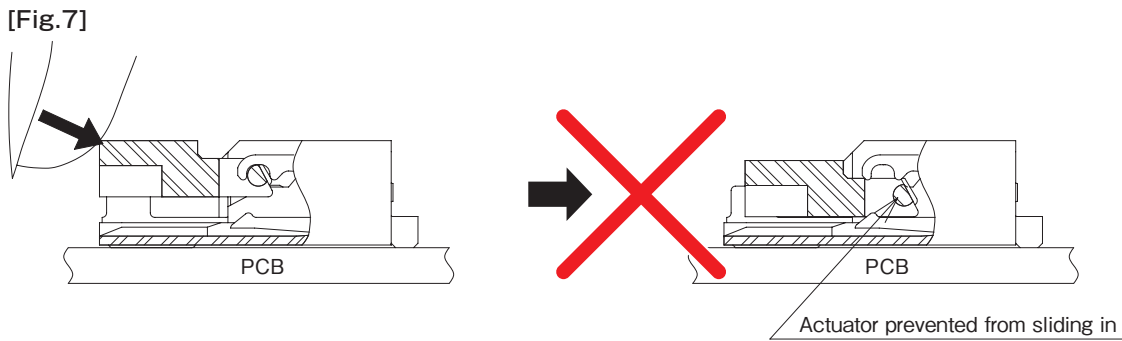
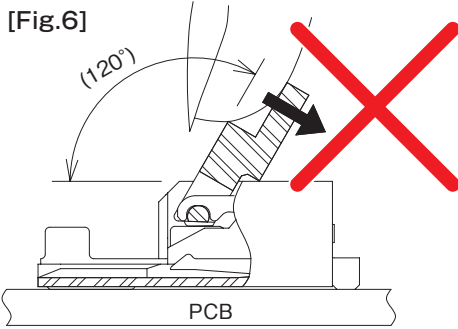

### 3. FPC/FFC Insertion Method

This connector uses a bottom contact point.

Additionally, this connector is equipped with retaining tabs for positioning FPC/FFC.

Hold FPC/FFC with the conductor side facing down,

and insert FPC/FFC from above diagonally at an angle of about 20° to the board. [Fig.10]

[Caution]

- Be careful not to insert FPC/FFC with the conductor side facing upwards.
- Be sure to insert FPC/FFC to the end.
- Do not insert FPC/FFC from above diagonally at a large angle. [Fig.11]
- Insert FPC/FFC while the actuator is open. [Fig.12]
- Do not twist the FPC/FFC vertically, horizontally or diagonally. [Fig.13]

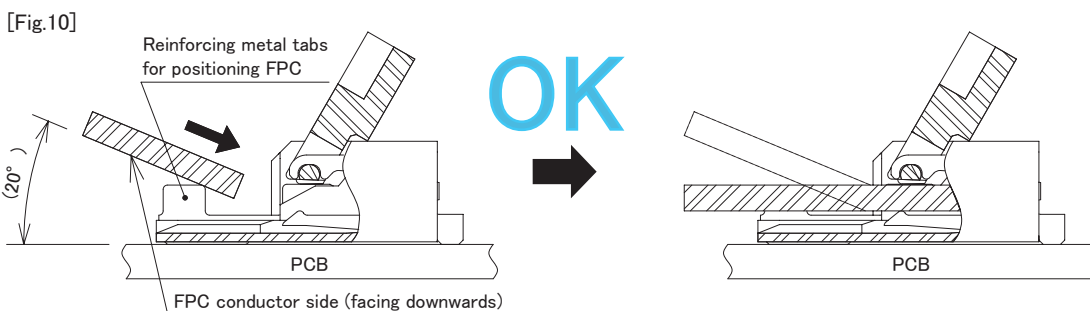

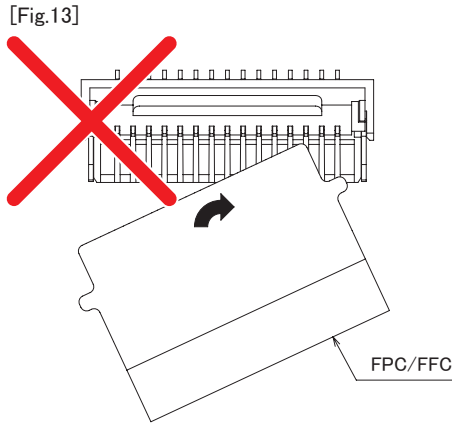
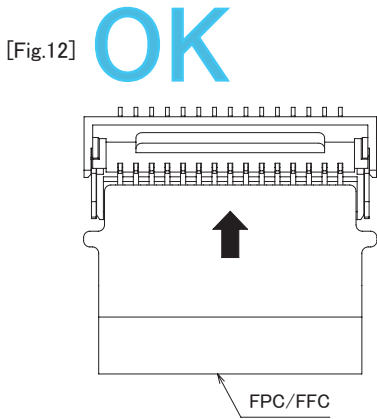
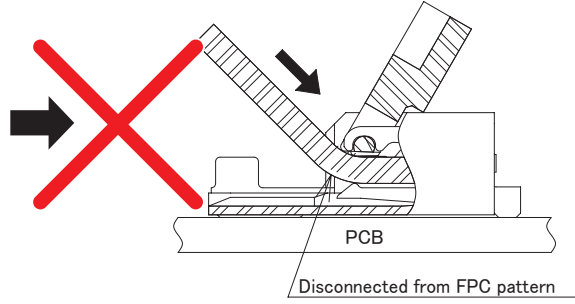
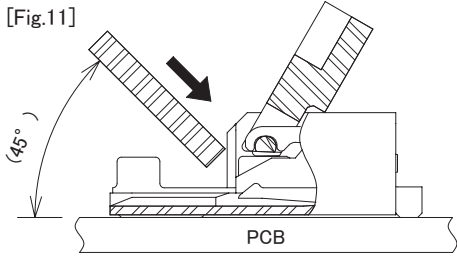

#### 4. FPC/FFC Insertion Confirmation

This connector uses retention tabs for positioning FPC/FFC.

When insertion of FPC/FFC is complete, confirm that the FPC/FFC positioning tab is located at the place shown in the Figure. [Fig.14]

[Caution]

- Avoid shallow insertion or insertion at a slant. [Fig.15, Fig.16]

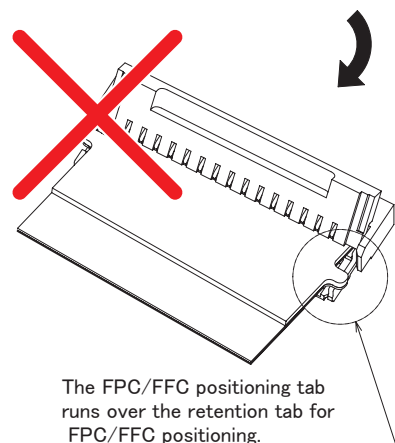
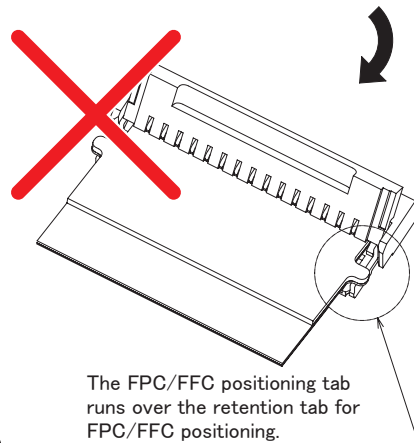
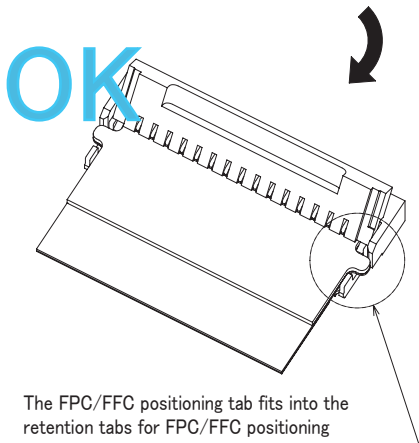
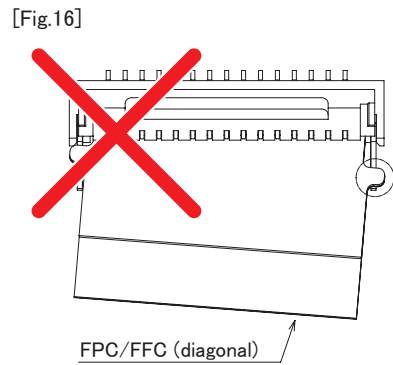
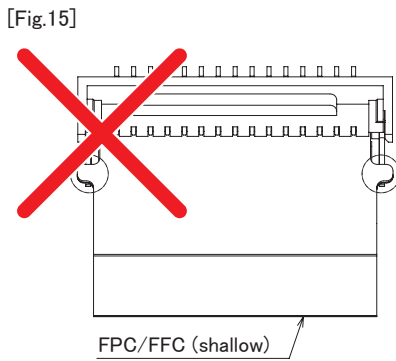
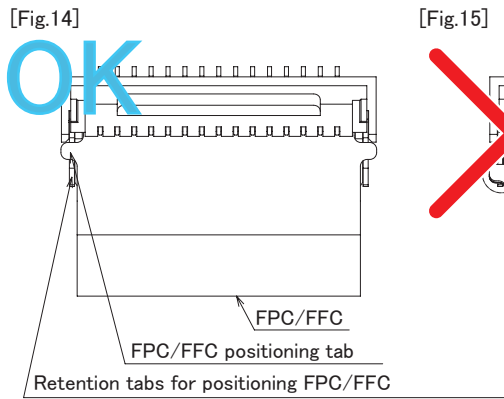



## 5. Actuator Locking Method

The actuator rotates at its center.

After inserting FPC/FFC correctly to the end, operate the actuator by rotating it, and then lock in place. [Fig.17]

[Caution]

- Operate the actuator close to its center. [Fig.18]
- Do not operate the actuator only on one side. [Fig.19]
- Operate the actuator by hand, take care not to allow jigs or nails to get inside the connector.
- Do not operate the actuator in the direction opposite to the closing direction.
- Do not pick and raise the actuator, or hook it.
- Please check to insure the actuator is placed horizontal to the board surface when locked.

[Fig.17]

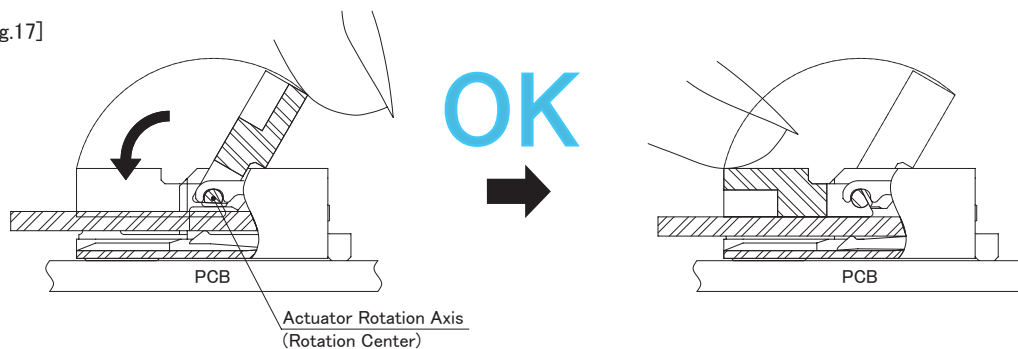

[Fig.18]

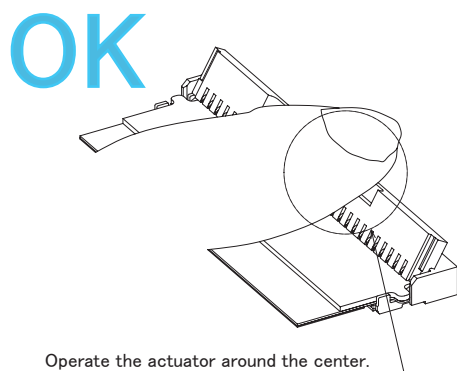

[Fig.19]

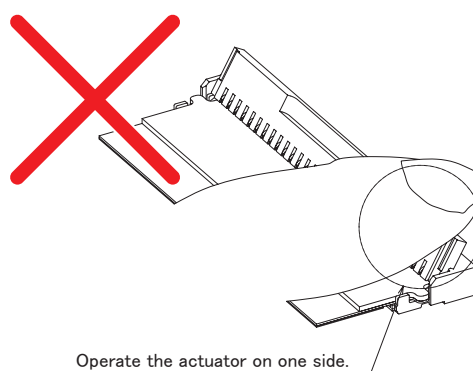

## 6. Check the mated state of FPC/FFC

When the actuator is completely locked, visually inspect the insertion status of FPC/FFC. [Fig.20]

[Caution]

- Do not insert FPC/FFC insufficiently deep or from a diagonal direction. [Fig.21, Fig.22]

[Fig.20]

When FPC/FFC is correctly inserted, the FPC/FFC positioning tab sits in the retention tabs for FPC/FFC positioning.

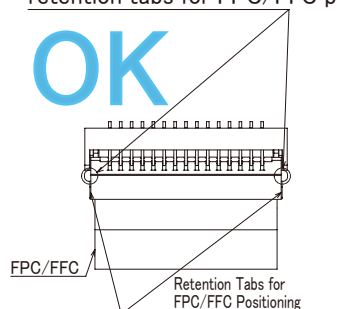

[Fig.21]

If FPC/FFC is not correctly inserted (or is not inserted deep enough), the FPC/FFC positioning tab will not sit in the retention tabs for FPC/FFC positioning and sticks out of the connector.

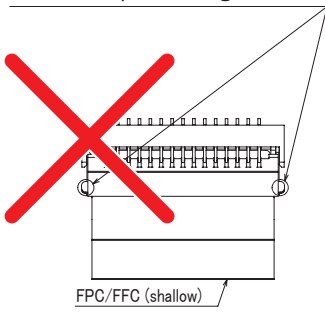

[Fig.22]

If FPC/FFC is not correctly inserted (or is inserted diagonally), part of the FPC/FFC positioning tab does not go in the retention tabs for FPC/FFC positioning and sticks out of the connector.

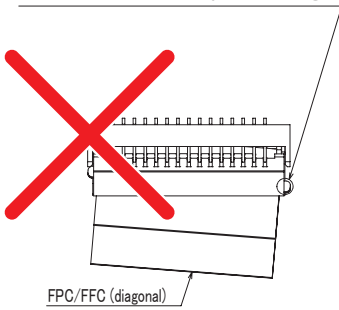

## 7. Actuator Lock Release Method (FPC/FFC inserted)

Slowly raise the actuator and release the lock. [Fig.23]

[Caution]

- Operate the actuator close to its center. [Fig.24]
- Do not operate the actuator on only one side. [Fig.25]
- Operate the actuator by hand, take care not to allow jigs or nails to get into the connector.
- Actuator cannot be opened wider than 120°. Do not try to force it open wider than that angle. [Fig.26]
- Do not pick and raise the actuator, or hook it. [Fig.27]

[Fig.23]

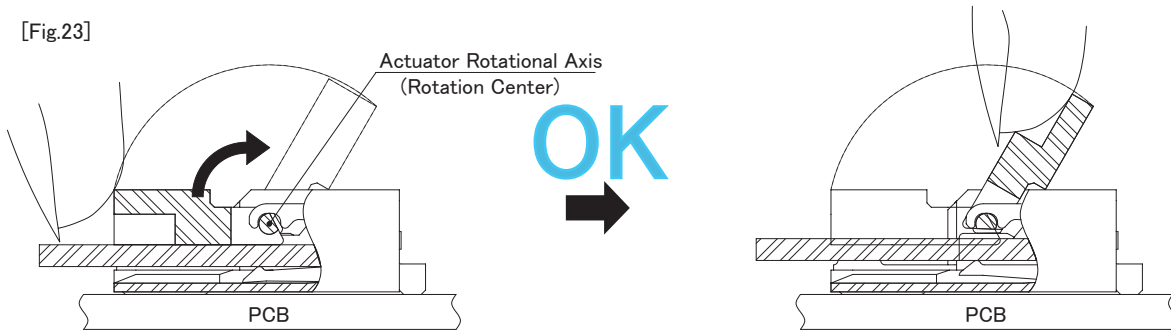

[Fig.24]

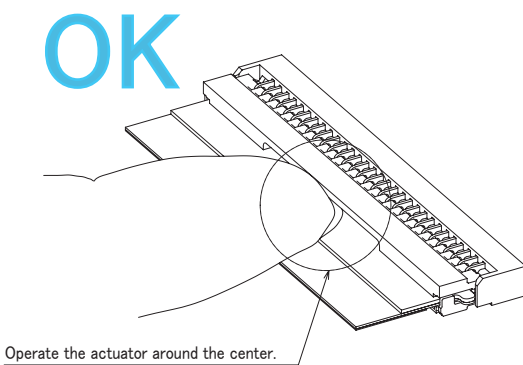

[Fig.25]

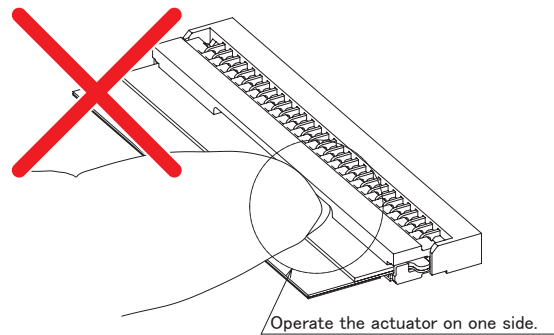

[Fig.26]

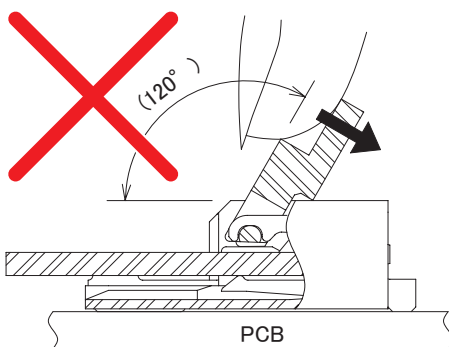

[Fig.27]

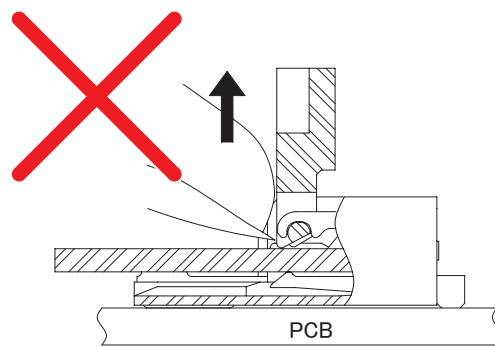

### 8. FPC/FFC Removal Method

This connector uses retention tabs for FPC/FFC positioning.

After unlocking the actuator, pull out the FPC/FFC diagonally at an angle of about 20° to the board. [Fig.28]

[Caution]

- Do not remove the FPC/FFC in the horizontal direction.
- Do not remove the FPC/FFC from above diagonally at a large angle. [Fig.29]
- Do not remove the FPC/FFC while the actuator is closed. [Fig.30]

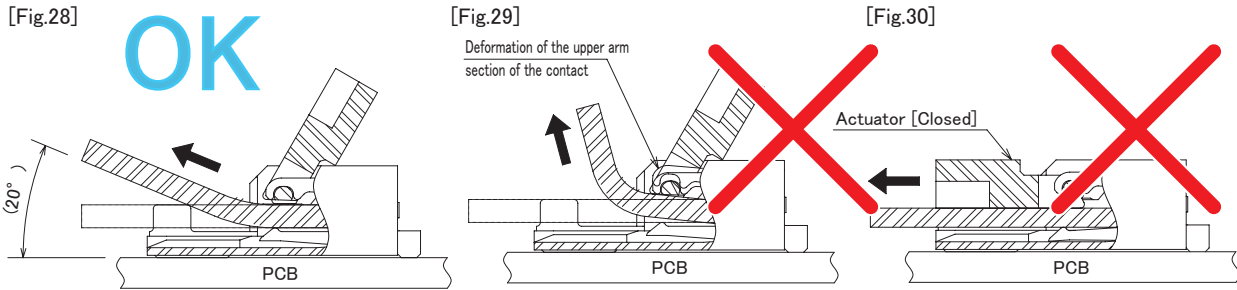

#### [Cautions for PCB Layout]

Depending on the routing of FPC/FFC to mate, a load may be applied to the connector, which could lead to contact failure. In order to prevent any failure, please consider the following.

[Caution]

- Please ensure there is no load applied to the connector in the pulling, inserting or lateral direction. [Fig.31]
- Please ensure that no extreme tensile force or upward force etc. is applied to the connector in the vertical direction.
- When routing FPC/FFC, please ensure that the FPC/FFC is not pulled and routing is carried out with adequate margin. Please check that the reinforcing film is placed horizontal to the board surface. [Fig.32]
- Do not route the FPC/FFC to bend around the connector. [Fig.33]
- Please take care with the FPC/FFC so that no direct force is applied to the connector section.
- Please do not place any parts under the FPC/FFC reinforcing film that will interfere with FPC/FFC. [Fig.34]
- Please confirm the recommendations of in this document for the shape of FPC/FFC. In addition, for the flexibility of FPC/FFC, please make adjustments with the FPC/FFC manufacturer.
- When designing, please ensure there is adequate space for FPC/FFC insertion so that it is not inserted at an extreme diagonal. In addition, a short FPC/FFC will make insertion difficult, please use adequate layout and length for FPC/FFC.
- When designing a board layout, please secure the space required for actuator closure and operation.

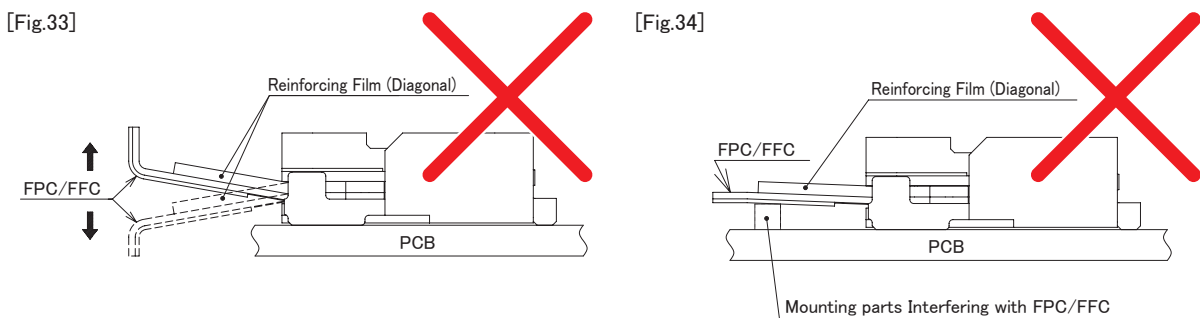
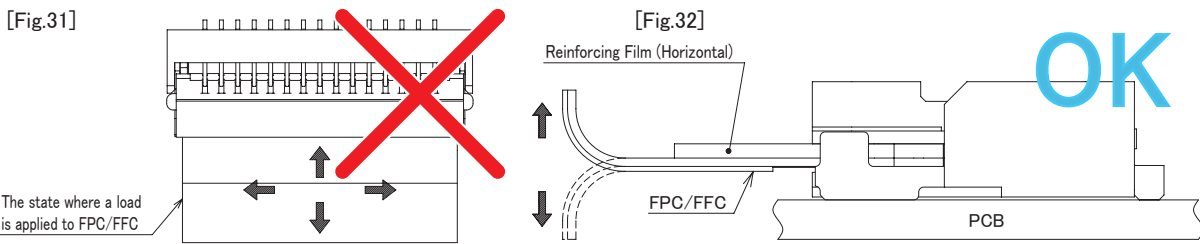

## [Notes for Board Mounting]

### [Caution]

- Please confirm recommendations for mount board land shape, metal mask opening shape, and FPC/FFC shape.
- If the land is narrower than recommended, or if the metal mask opening is wider than recommended, solder (flux) wicking is more likely to occur. If there is difference from the recommendation, please use after checking the mounted state.
- The level difference between the bottom surfaces of contact lead and the mold is designed to be small. When there is silk print etc. on the bottom surface of the connector, it could push up the connector bottom surface, and cause non-sticking solder or defective fillet formation. When there is silk print etc. on the bottom surface of the connector, please use it after checking the mounted state.
- Use the reflow conditions within the specification. The mounted status may vary due to external conditions such as the type of cream solder, manufacturer, and board size. Please use after checking the mounted state.
- Please control the board warpage as much as possible. While the coplanarity of this connector is 0.1mm or less, if there is considerable board warpage, defective soldering could occur.
- When mounted on FPC/FFC, be sure to provide a reinforcing plate to make it easier to handle. A reinforcing plate of 0.3mm or thicker made of glass epoxy material is recommended.
- When you remove the emboss from the reel, or when you absorb the connector from the emboss and so on, do not apply any excessive external force to the connector before mounting. (1N or less)

## [Cautions When Handling the Board After Mounting]

Please be careful of the following when handling the board after mating.

### [Caution]

- Do not apply any load to the board in the assembly process, such as by dividing a multi-piece board or securing a board to the frame. Such actions may result in a load being applied to the connector and connector damage.
- Use a board with a deflection of 0.5mm or less when the board width is 100mm.  
If the board has some deflection, it could apply a load to the connector and damage it.

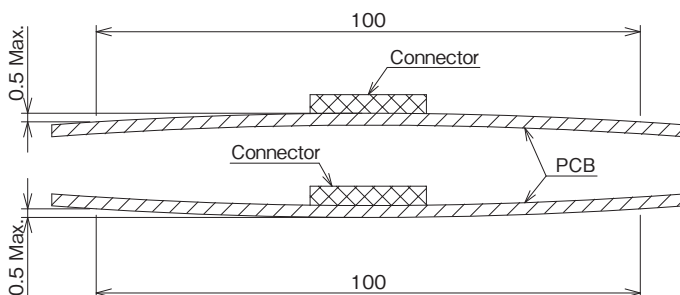

## [Cautions for Hand-soldering]

Note the following when performing soldering during repair, etc.

### [Caution]

- Do not perform manual soldering with the FPC/FFC inserted in the connector.
- Do not apply excessive heat to the connector or let the soldering iron in contact with any parts other than the contact leads. Failure to do so may result in connector deformation or melting.
- Do not supply excessive solder (flux).

If excessive solder (flux) is applied to the contacts solder or flux may adhere to the contacts or the rotating portion of the actuator, resulting in poor contact or poor actuator rotation. Supplying excessive solder to the retention tabs may result in actuator rotation failure, causing connector damage.

## While taking in consideration

Specifications mentioned in this catalog are reference values.

When considering to order or use this product, please review the Drawing and Product Specifications sheets.

Use an appropriate cable when using the connector in combination with cables.

If considering usage of a non-specified cable, please contact your sales representative.

If assembly process is done by jigs & tools which are not identified by Hirose, the warranty of the product may be affected.

If considering usage for below mentioned applications, please contact your sales representative.

In cases where the application will demand a high level of reliability, such as automotive, medical instruments, public infrastructure, aerospace/defense etc. Hirose must review before assurance of reliability can be given.

**HIROSE**



**HIROSE ELECTRIC CO.,LTD.**

2-6-3 Nakagawa Chuoh, Tsuzuki-Ku, Yokohama-Shi 224-8540, JAPAN  
<https://www.hirose.com>