

General Description

The SGM2019-1.8Y N5G/TR series are a group of low-dropout (LDO)voltage regulators offering the benefits of wide input voltage range from 1.2V to 5.5V, low dropout voltage, low power consumption, and miniaturized packaging.

Quiescent current of only 2 μ A makes these devices ideal for powering the battery-powered, always-on systems that require very little idle-state power dissipation to a longer service life. There is an option of shutdown mode by selecting the parts with the EN pin and pulling it low. The shutdown current in this mode goes down to only 10nA (typical).

The SGM2019-1.8Y N5G/TR series of linear regulators are stable with the ceramic output capacitor over its wide input range from 1.2V to 5.5V and the entire range of output load current (0mA to 300mA).

Features

- 2 μ A Ground Current at no Load
- \pm 2% Output Accuracy
- 300mA Output Current
- 10nA Disable Current (by option)
- Wide Operating Input Voltage Range: 1.2V to 5.5V
- Dropout Voltage: 0.16V at 300mA/ VOUT 3.3V
- Support Fixed Output Voltage 0.8V, 0.9V, 1.2V, 1.5V, 1.6V, 1.8V, 2.5V, 2.8V, 3.0V, 3.3V
- Adjustable Output Voltage Available by Specific Application
- Stable with Ceramic or Tantalum Capacitor
- Current Limit Protection
- Over-Temperature Protection
- SOT-23-3, SOT-23-5, DFN-4L 1x1 and DFN-6L 2x2 Packages Available

Pin Configurations

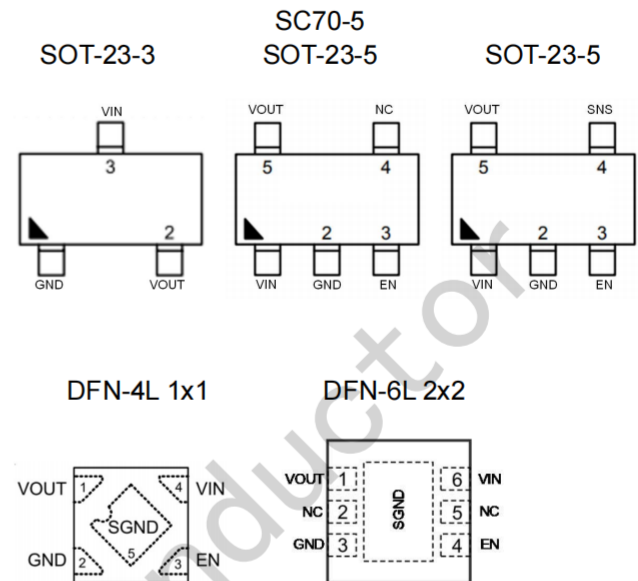

Applications

- Portable, Battery Powered Equipment
- Low Power Microcontrollers
- Laptop, Palmtops and PDAs
- Wireless Communication Equipment
- Audio/Video Equipment
- Car Navigation Systems

Description of Functional Pins

SGM2019-1.8Y N5G/TR

Pin No				Pin Name	Pin Function
SOT-23-3	SOT-23-5	DFN-1X1	DFN-2X2		
1	2	2	3	GND	Ground
2	5	1	1	VOUT	Output of the Regulator
3	1	4	6	VIN	Input of Supply Voltage.
	3	3	4	EN	Enable Control Input.
	4		2,5	NC	No internal connection
		Exposed Pad	Exposed Pad	SGND	Substrate of Chip. Leave floating or tie to GND.

SGM2019-1.8YN5G/TRN (For SOT-23-5 with SNS pin)

Pin No	Pin Name	Pin Function
SOT-23-5		
2	GND	Ground
5	VOUT	Output of the Regulator
1	VIN	Input of Supply Voltage.
3	EN	Enable Control Input.
4	SNS	Sense of Output Voltage.

Typical Application Circuit

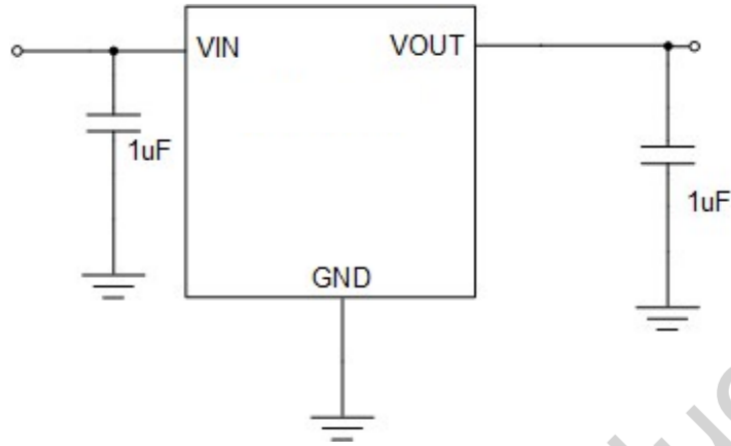

Figure 1: Application circuit of Fixed V_{OUT} LDO

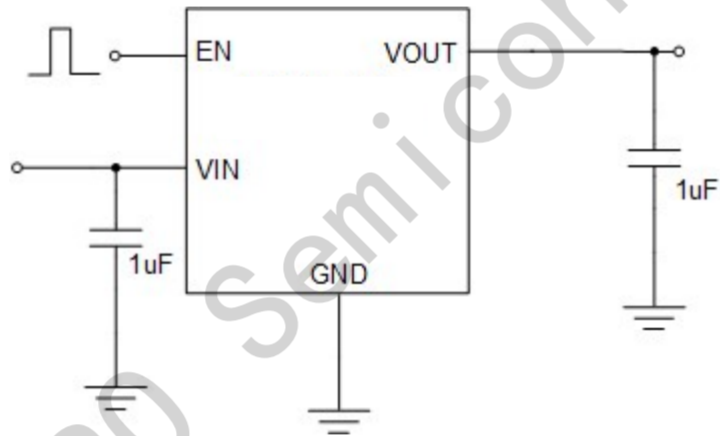

Figure 2: Application circuit of Fixed V_{OUT} LDO with enable function

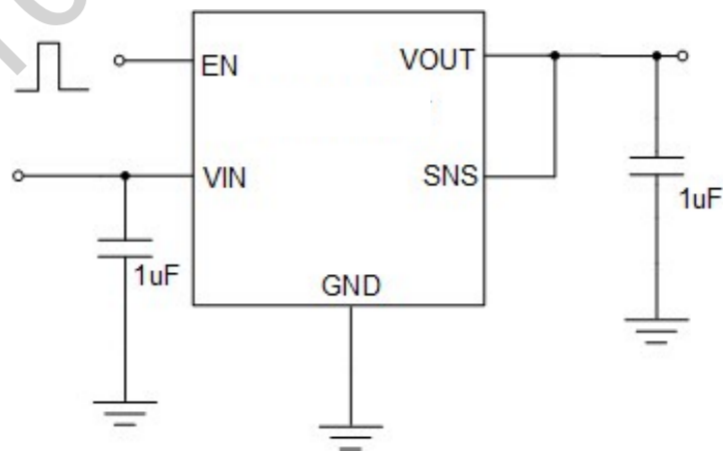

Figure 3: Application circuit of Fixed V_{OUT} LDO with enable and sense functions

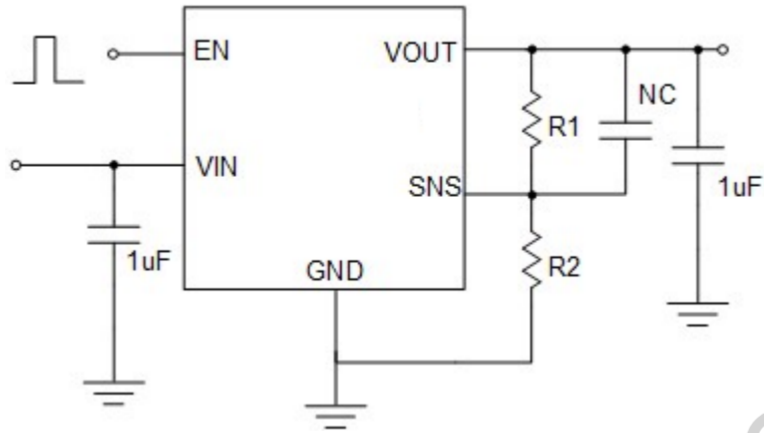
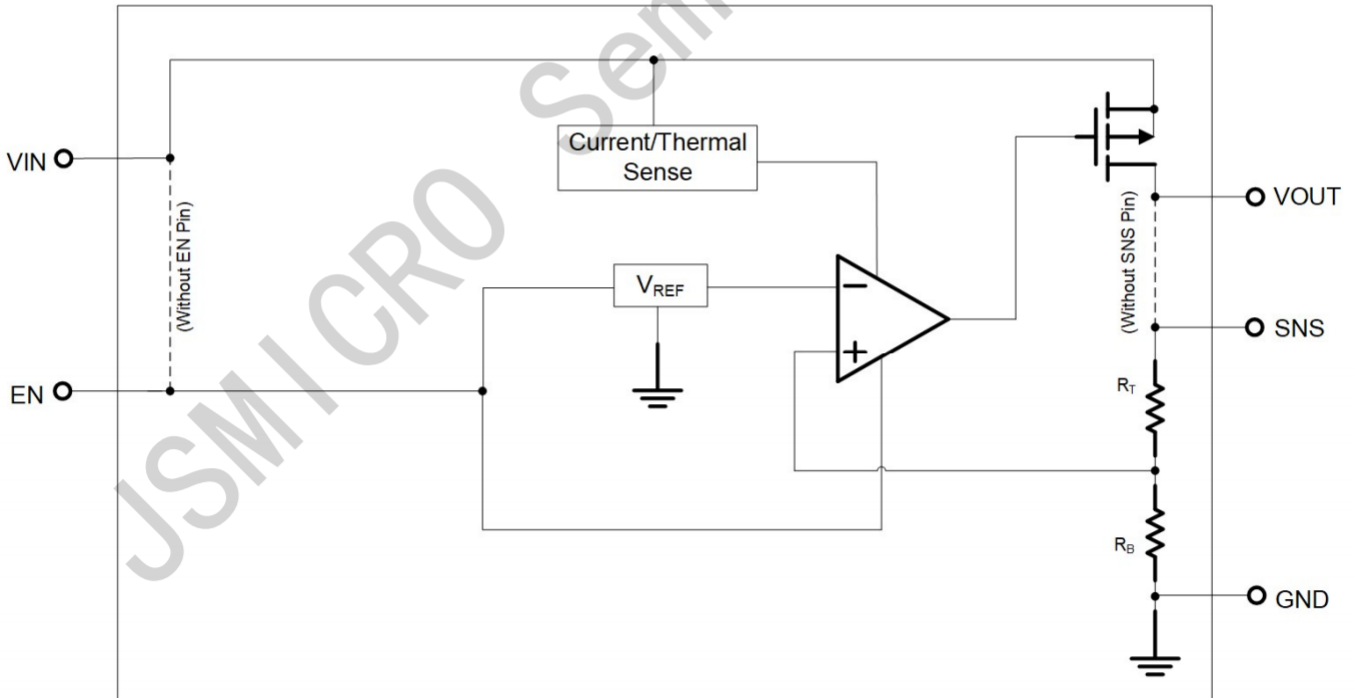

Figure 4: Adjustable output voltage LDO application circuit by SGM2019-1.8YN5G/TR

Function Block Diagram



Absolute Maximum Ratings (Note 1)

VIN to GND	-----	-0.3V to 6.5V
VOUT, EN, SNS to GND	-----	-0.3V to 6V
VOUT to VIN	-----	-6V to 0.3V
Package Thermal Resistance (Note 2)		
SOT-23-5, SOT-23-3, θ_{JA}	-----	200 °C /W
DFN-4L 1x1, θ_{JA}	-----	130 °C /W
DFN-6L 2x2, θ_{JA}	-----	95 °C /W
Lead Temperature (Soldering, 10 sec.)	-----	260 °C
Junction Temperature	-----	150 °C
Storage Temperature Range	-----	-60 °C to 150 °C
ESD Susceptibility		
HBM	-----	2KV
MM	-----	200V
CDM	-----	2KV

Recommended Operating Conditions

Input Voltage VIN	-----	1.2V to 5.5V
Junction Temperature Range	-----	-40 °C to 125 °C
Ambient Temperature Range	-----	-40 °C to 85 °C

Electrical Characteristics

($V_{IN} = 5V$, $V_{EN} = 5V$ $T_A = 25^\circ C$ unless otherwise specified)

Parameter	Symbol	Test Conditions	Min	Typ	Max	Unit	
Supply Voltage	V_{IN}		1.2	--	5.5	V	
DC Output Voltage Accuracy		$I_{LOAD} = 0.1mA$	-2		2	%	
Dropout Voltage ($I_{LOAD} = 300mA$) (Note 3)	V_{DROP_3V}	$V_{OUT} \geq 3V$	--	0.16		V	
	$V_{DROP_2.8V}$	$V_{OUT} = 2.8V$		0.18			
	$V_{DROP_2.5V}$	$V_{OUT} = 2.5V$		0.2			
	$V_{DROP_1.8V}$	$V_{OUT} = 1.8V$		0.25			
	$V_{DROP_1.5V}$	$V_{OUT} = 1.5V$		0.31			
	$V_{DROP_1.2V}$	$V_{OUT} = 1.2V$		0.41			
	$V_{DROP_0.9V}$	$V_{OUT} = 0.9V$		0.61			
Ground Current	I_Q	$I_{LOAD} = 0mA$		2		μA	
Shutdown Ground Current	I_{SD}	$V_{EN} = 0V$,		0.01	0.5	μA	
V_{OUT} Shutdown Leakage Current	I_{LEAK}	$V_{OUT} = 0V$		0.01	0.5		
SNS Input Current	I_{SNS}	$SNS = V_{OUT}$		0.7		μA	
Enable Threshold Voltage	V_{IH}	EN Rising			2	V	
	V_{IL}	EN Falling	0.6				
EN Input Current	I_{EN}	$V_{EN} = 5V$		10	100	nA	
Line Regulation	$\Delta LINE$	$I_{LOAD} = 30mA$, $1.5V \leq V_{IN} \leq 5.5V$ or $(V_{OUT} + 0.2V) \leq V_{IN} \leq 5.5V$		0.2		%	
Load Regulation	$\Delta LOAD$	$10mA \leq I_{LOAD} \leq 0.3A$		0.2		%	
Output Current Limit	I_{LIM}	$V_{OUT} = 0$	301	600		mA	
Power Supply Rejection Ratio ($I_{LOAD} = 5mA$)	PSRR	$V_{OUT} = 1.2V$,	$f = 100Hz$	--	80	--	dB
		$V_{IN} = 2V$	$f = 1kHz$	--	75	--	
Output Voltage Noise (BW = 10Hz to 100kHz, $C_{OUT} = 1\mu F$.)		$V_{IN} = 3.5V$	$V_{OUT} = 0.9V$	--	40	--	μV_{RMS}
		$I_{LOAD} = 0.1A$	$V_{OUT} = 2.8V$	--	50	--	
Thermal Shutdown Temperature	T_{SD}	$I_{LOAD} = 10mA$	--	155	--	$^\circ C$	
Thermal Shutdown Hysteresis	ΔT_{SD}		--	15	--	$^\circ C$	

Note 1. Stresses beyond those listed “Absolute Maximum Ratings” may cause permanent damage to the device. These are stress ratings only, and functional operation of the device at these or any other conditions beyond those indicated in the operational sections of the specifications is not implied. Exposure to absolute maximum rating conditions may affect device reliability.

Note 2. θ_{JA} is measured at $T_A = 25^\circ\text{C}$ on a DSTECH EVB board.

Note 3. $V_{DROP} = V_{IN} - V_{OUT}$ when the V_{OUT} is 98% of its target value.

JSMICRO Semiconductor

Typical Characteristics

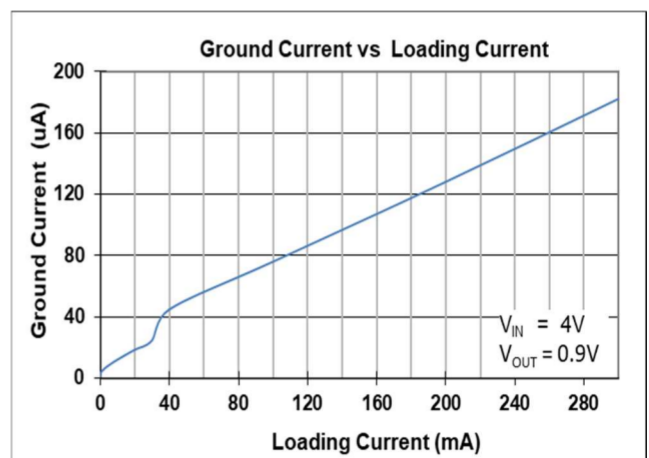
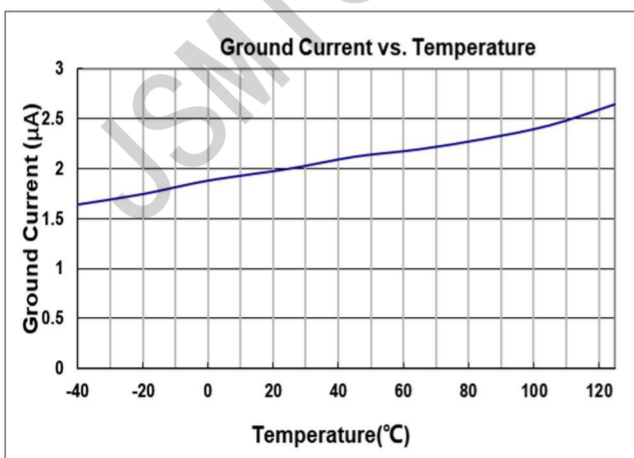
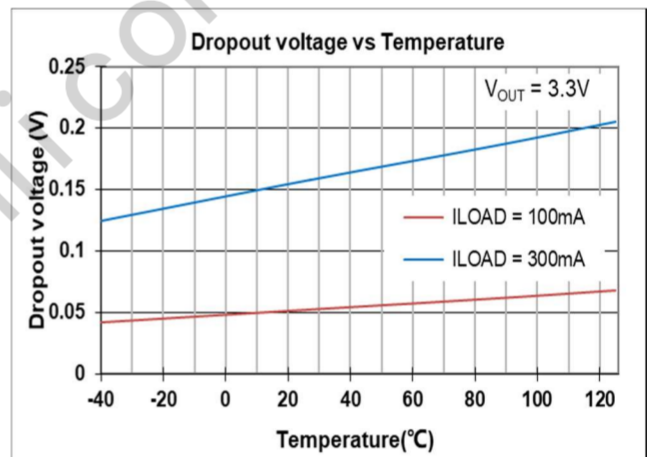
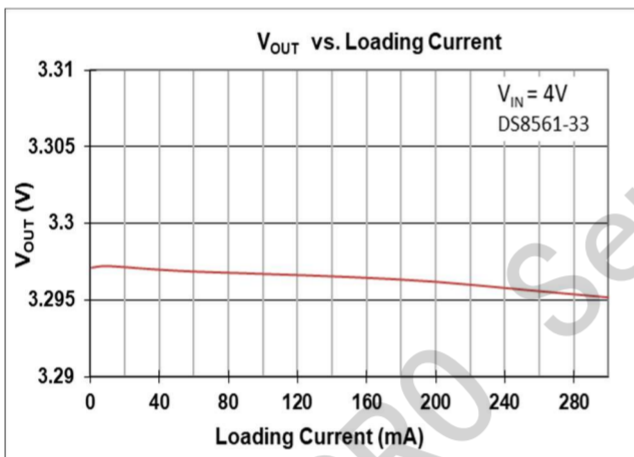
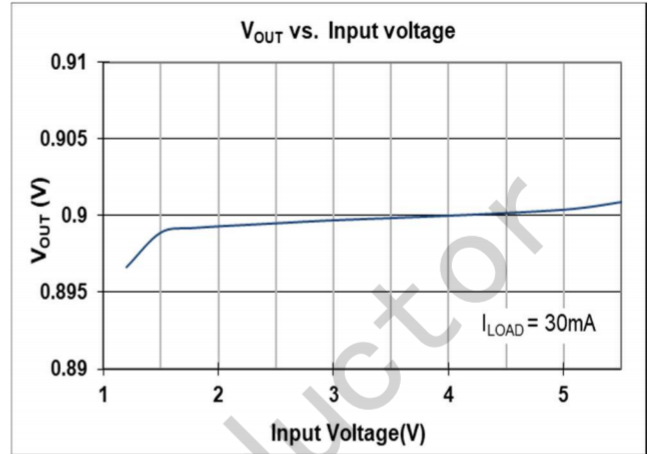
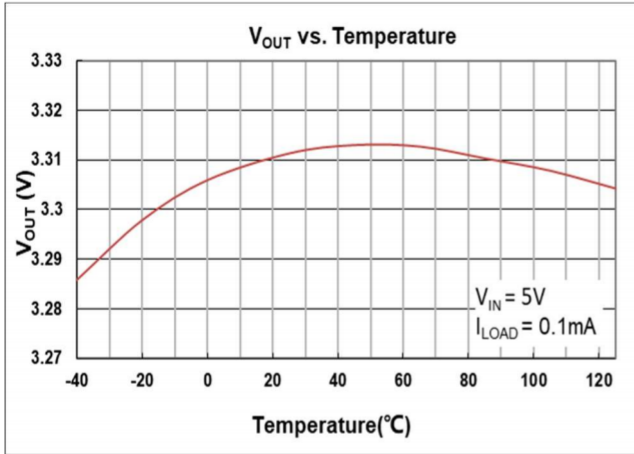

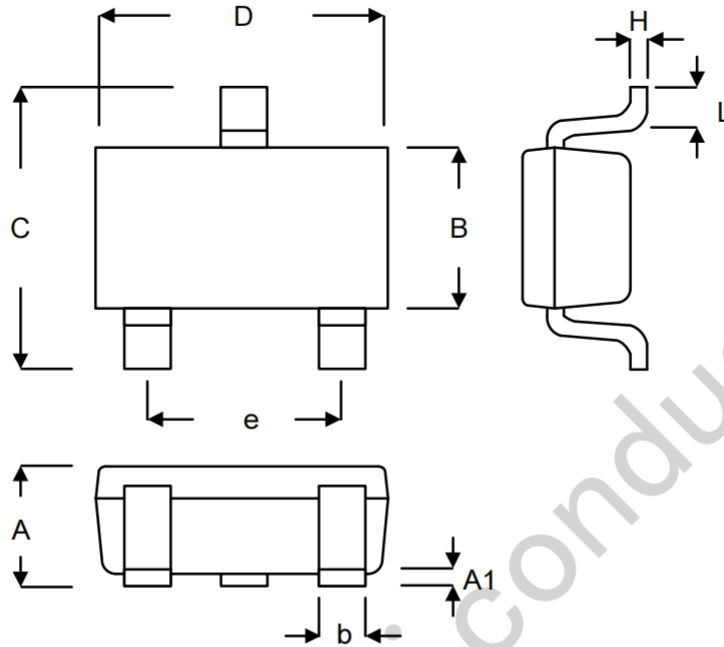
Package Information:

Symbol	Millimeters		Inches	
	Min.	Max.	Min.	Max.
A	0.889	1.295	0.035	0.051
A1	0.000	0.152	0.000	0.006
B	1.397	1.803	0.055	0.071
b	0.250	0.560	0.010	0.022
C	2.591	2.997	0.102	0.118
D	2.692	3.099	0.106	0.122
e	1.803	2.007	0.071	0.079
H	0.080	0.254	0.003	0.010
L	0.300	0.610	0.012	0.024

SOT-23-3L

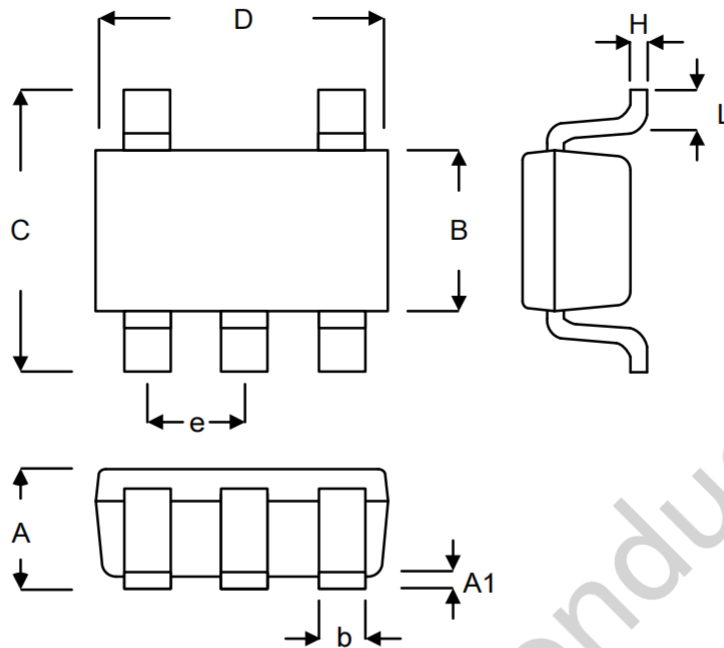

Symbol	Millimeters		Inches	
	Min.	Max.	Min.	Max.
A	0.889	1.295	0.035	0.051
A1	0.000	0.152	0.000	0.006
B	1.397	1.803	0.055	0.071
b	0.250	0.560	0.010	0.022
C	2.591	2.997	0.102	0.118
D	2.692	3.099	0.106	0.122
e	0.838	1.041	0.033	0.041
H	0.080	0.254	0.003	0.010
L	0.300	0.610	0.012	0.024

SOT-23-5L

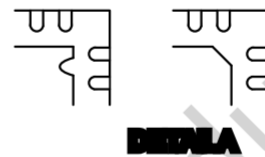
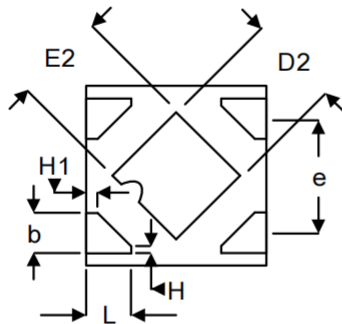
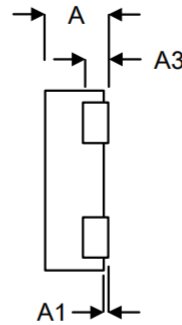
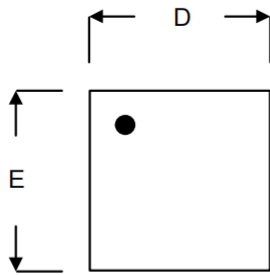

PIN #1 ID and Tie Bar Mark Options

Note : The configuration of the Pin #1 identifier is optional, but must be located within the zone indicated.

Symbol	Millimeters		Inches	
	Min.	Max.	Min.	Max.
A	0.300	0.400	0.012	0.016
A1	0.000	0.050	0.000	0.002
A3	0.117	0.162	0.005	0.006
b	0.175	0.280	0.007	0.011
D	0.900	1.100	0.035	0.043
D2	0.430	0.550	0.017	0.022
E	0.900	1.100	0.035	0.043
E2	0.430	0.550	0.017	0.022
e	0.650		0.026	
L	0.200	0.300	0.008	0.012
H	0.039		0.002	
H1	0.064		0.003	

DFN-1X1-4L

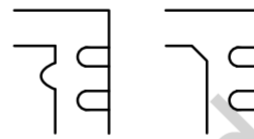
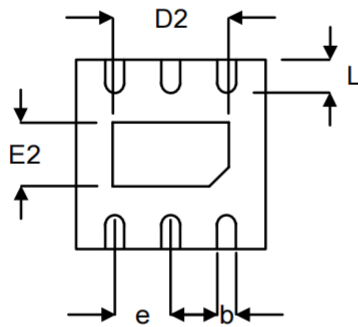
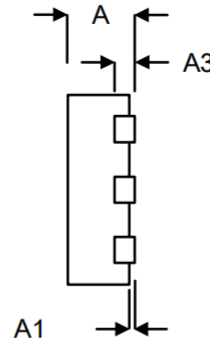
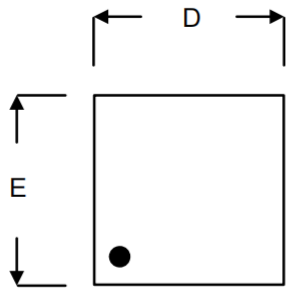

DIPOLA

PIN #1 ID and Tie Bar Mark Options
 Note : The configuration of the Pin #1 identifier is optional, but must be located within the zone indicated.

Symbol	Millimeters		Inches	
	Min.	Max.	Min.	Max.
A	0.700	0.800	0.028	0.031
A1	0.000	0.050	0.000	0.002
A3	0.175	0.250	0.007	0.010
b	0.200	0.350	0.008	0.014
D	1.950	2.050	0.077	0.081
D2	1.000	1.450	0.039	0.057
E	1.950	2.050	0.077	0.081
E2	0.500	0.850	0.020	0.033
e	0.650		0.026	
L	0.300	0.400	0.012	0.016

DFN-2X2-6L