

PART NUMBER	211942-0001	211942-0002	211942-0003
KEYING	A + B	A	B
COLOR	BLACK	RED	BLUE
PICTURE			

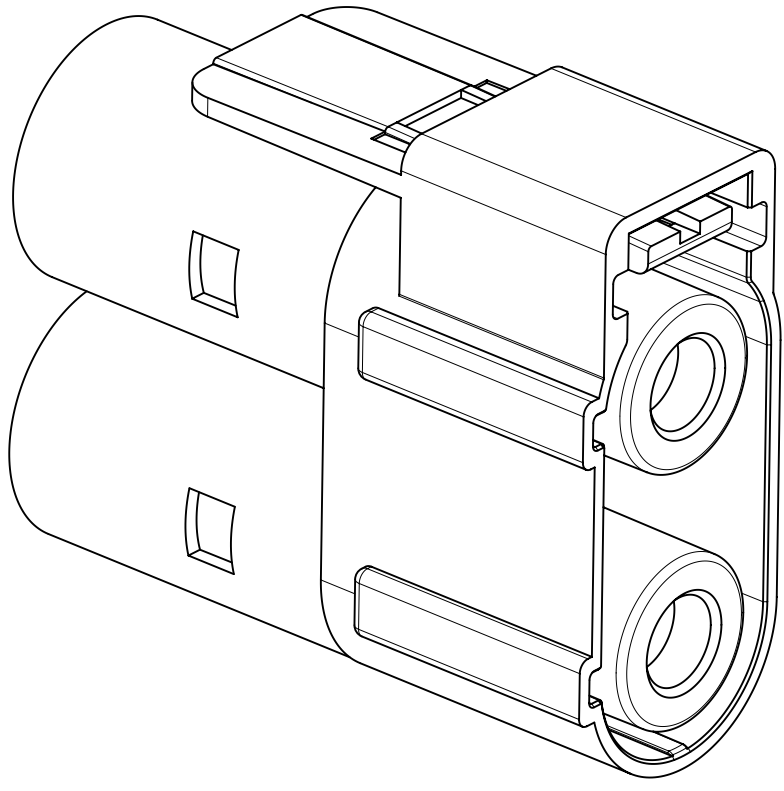
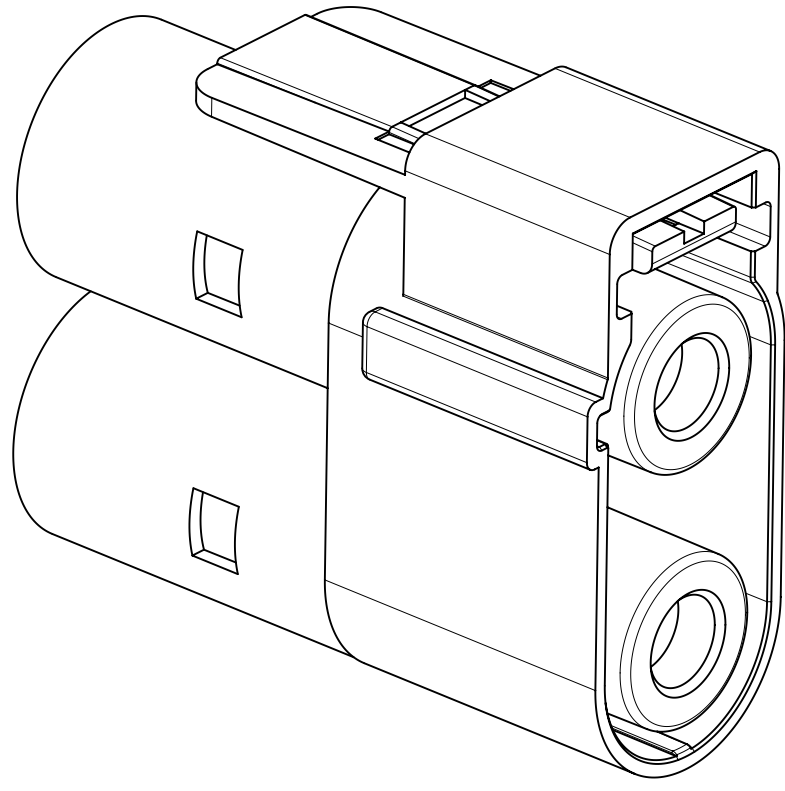
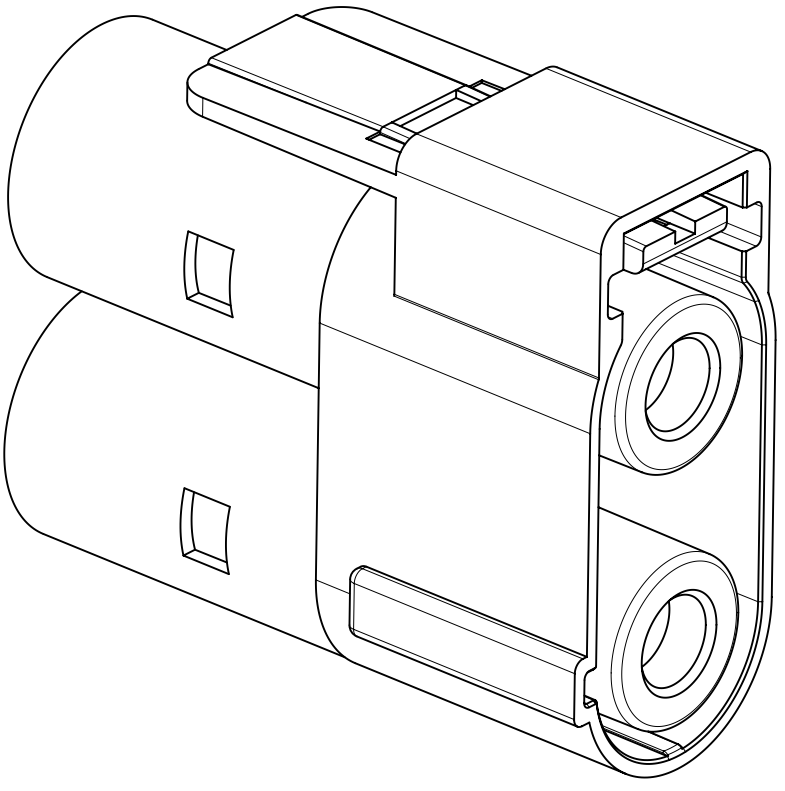
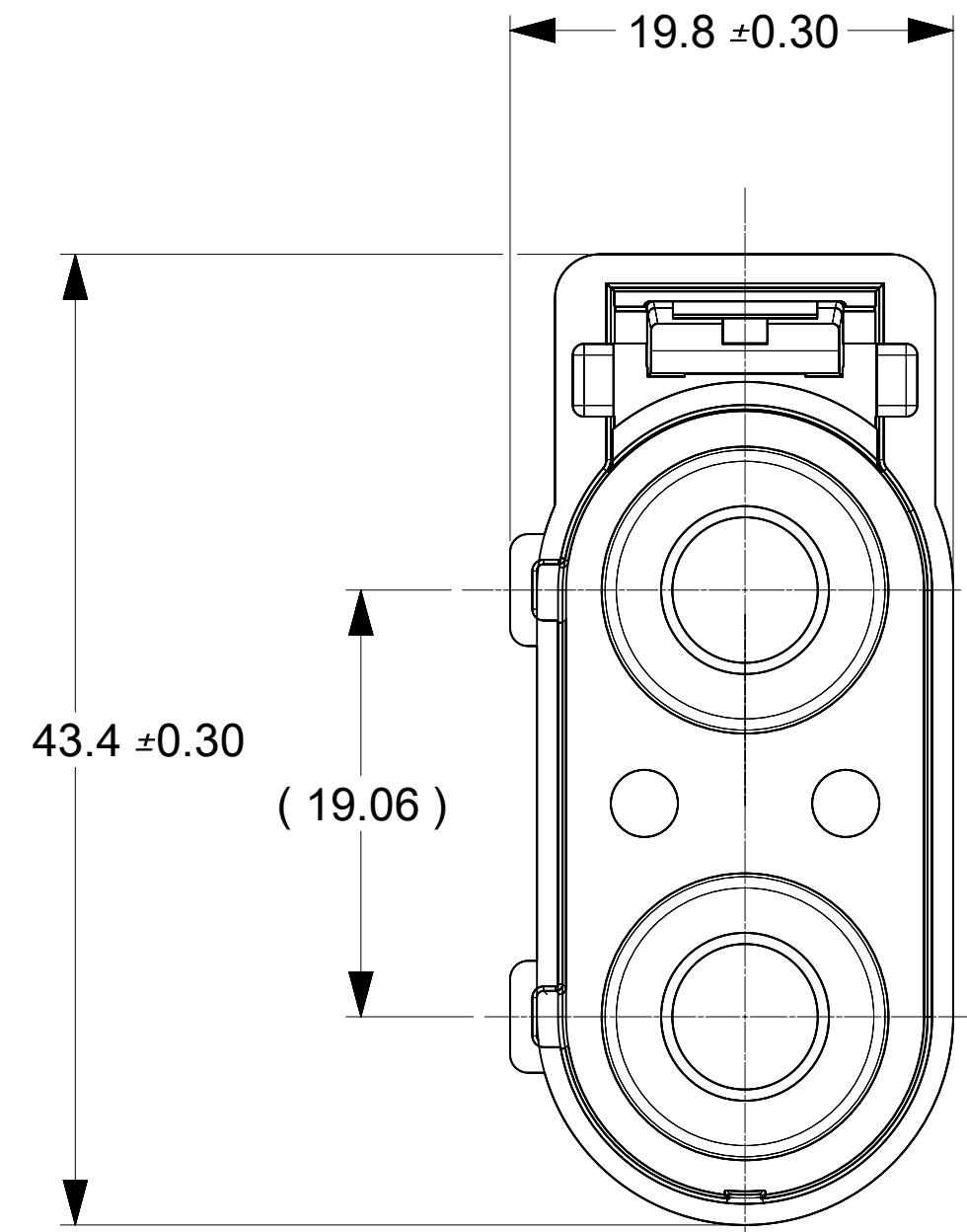
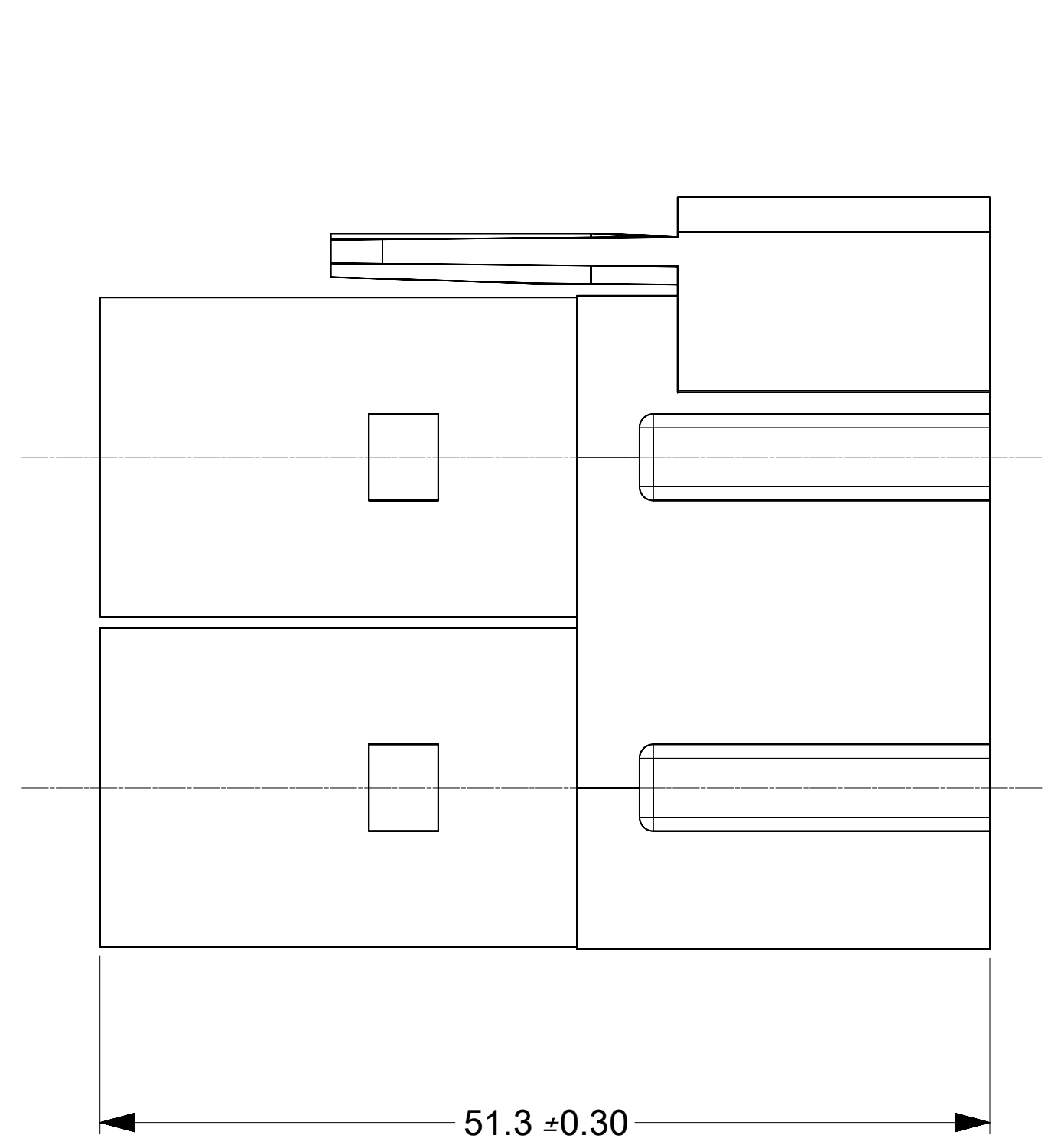
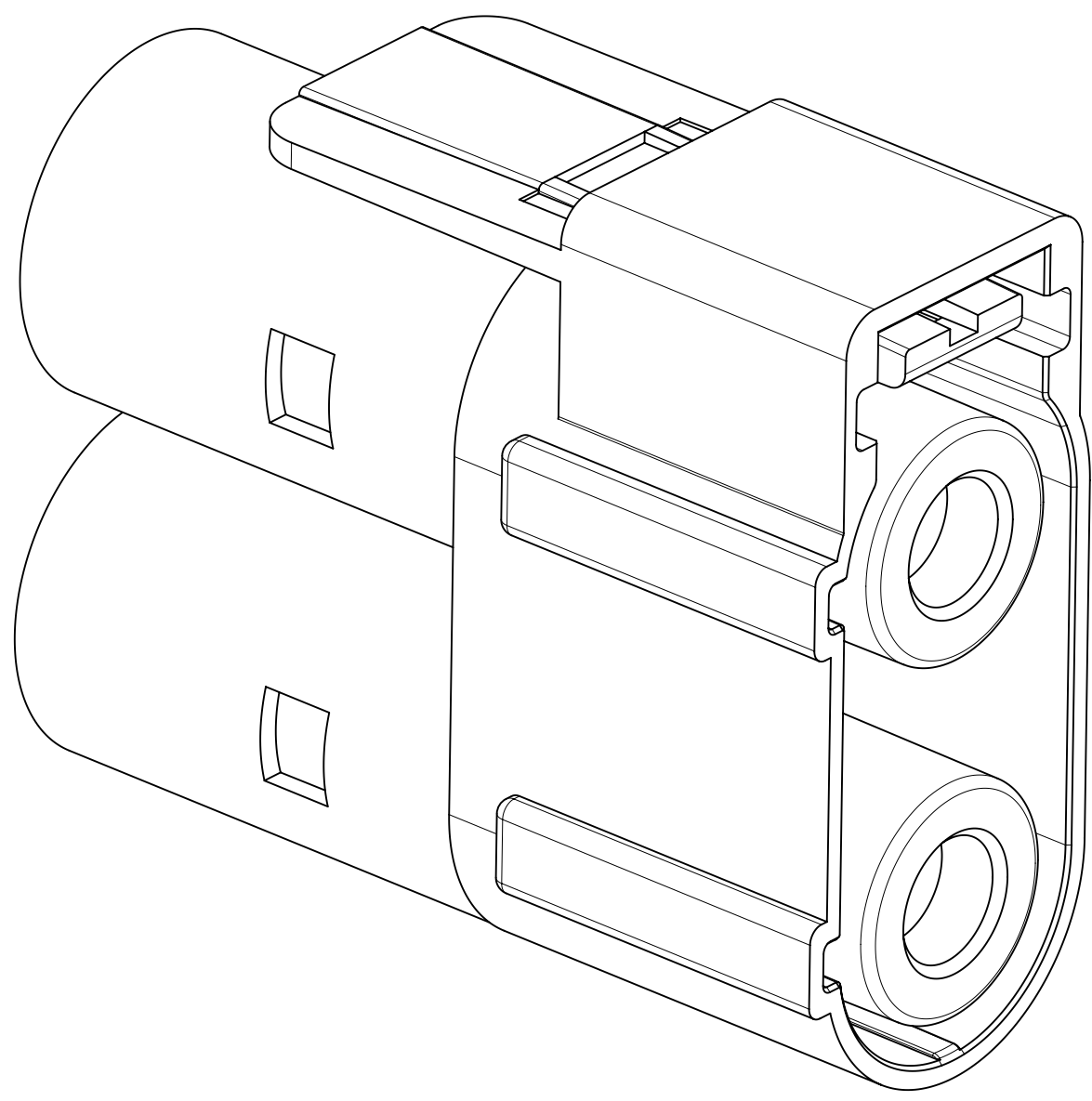
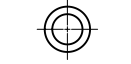

- NOTES:
1. MATERIAL: POLYESTER. UL 94- V0
 2. PACKAGE SPECIFICATION: 2119420000-PK
 3. FOR 6MM CST HARNESS ASSEMBLY, SERIES 211941.
 4. ROHS COMPLIANT.
 5. PRODUCT SPECIFICATION: 2119410000-PS
 6. APPLICATION SPECIFICATION: 2119410000-AS

THIS DRAWING CONTAINS INFORMATION THAT IS PROPRIETARY TO MOLEX ELECTRONIC TECHNOLOGIES, LLC AND SHOULD NOT BE USED WITHOUT WRITTEN PERMISSION											
DIMENSION UNITS		SCALE		CURRENT REV DESC:							
mm		NTS		<p>molex</p> <p>HOUSING; RECEPTACLE 2CKT 6MM CST</p> <p>PRODUCT CUSTOMER DRAWING</p> <p>DOCUMENT NUMBER: 2119420000-SD DOC TYPE: PSD DOC PART: 000 REVISION: A1</p>							
GENERAL TOLERANCES (UNLESS SPECIFIED)											
ANGULAR TOL ± °											
4 PLACES ±											
3 PLACES ±											
2 PLACES ± 0.15											
1 PLACE ± 0.25											
0 PLACES ±				INITIAL REVISION:							
DRAFT WHERE APPLICABLE MUST REMAIN WITHIN DIMENSIONS		THIRD ANGLE PROJECTION		DRAWING		SERIES		MATERIAL NUMBER		CUSTOMER	
				D-SIZE		211942		SEE CHART		1 OF 1	