

300mA, Low I_Q, High PSRR LDO Regulators

FEATURES

- 2.5V to 5.5V Input Voltage Range
- 320mV @300mA typical Dropout Voltage
- Excellent Transient Response
- Stable with 1μF Ceramic Output Capacitor
- 70dB PSRR at 1kHz
- Low Quiescent Current: 50μA typical.
- Low Shutdown Current: <1μA
- Output Accuracy: ±2%
- Fixed Output Voltage: 1.2V~3.3V
- Current Limit Protection
- Thermal Shutdown
- Output Auto-Discharge in Shutdown
- RoHS Compliant and 100% Lead (Fb)-Free Halogen-Free

APPLICATIONS

- Cellular Phones
- Bluetooth portable radios and Accessories
- Battery-Powered Equipment
- Laptop, Palmtops, Notebook Computer
- PDAs
- Digital still Camera and Video Recorders

GENERAL DESCRIPTION

The TMI6030 is a 300mA, low-dropout (LDO) linear regulator with fast transient response and high PSRR. It offers high output accuracy, low dropout voltage and low quiescent current as well as fast start-up time. This regulator is based on a CMOS process.

The TMI6030 is designed to work with low-ESR ceramic capacitors, reducing the amount of the PCB area necessary for power applications. Only a 1μF ceramic output capacitor can make the device stable over the whole load range current (0mA to 300mA).

The output voltage of TMI6030 can be set by an external resistors divider. When the FB pin is connected to an external resistors divider, its output can be adjusted from 1.2V to 5V. As to fixed output voltage version, a ceramic capacitor on BP pin could be used to improve output noise performance and PSRR performance. Other key features include over-current protection and thermal shutdown. The TMI6030 is packaged in DFN4L 1×1 and SOT23-5 packages.

TYPICAL APPILICATION

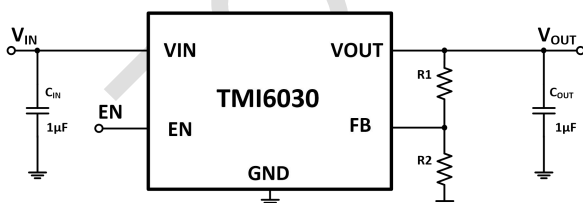

Figure 1. TMI6030 adjustable output Circuit

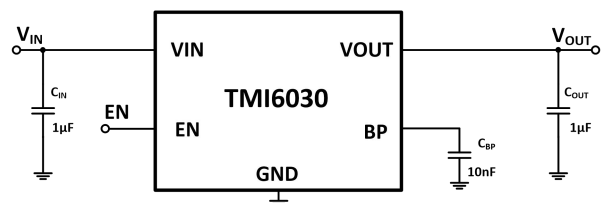

Figure 2. TMI6030 fixed output Circuit

BLOCK DIAGRAM

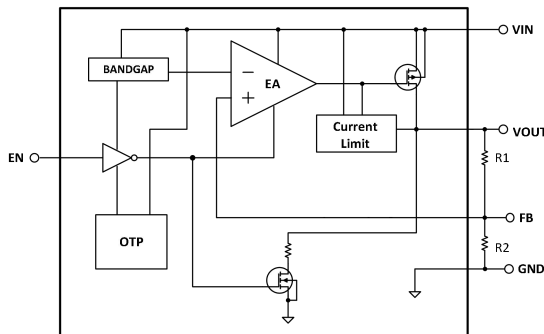

Figure 3. TMI6030 adjustable version function block

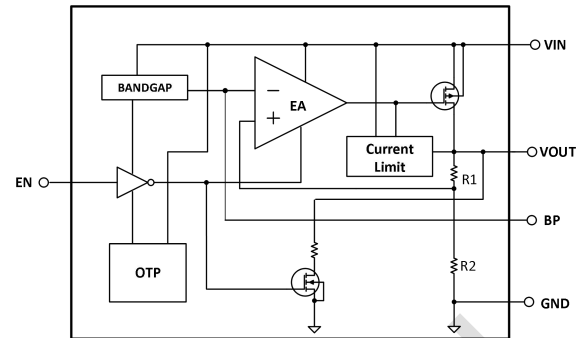

Figure 4. TMI6030 fixed version function block

ABSOLUTE MAXIMUM RATINGS

Description	Value	Unit
VIN, EN Input Voltage Range	-0.3~6	V
All other pins Voltage Range	-0.3 to (VIN+0.3)	V
Junction Temperature	160	°C
Storage Temperature Range	-65~150	°C
Junction-to-ambient Thermal Resistance	220 (SOT23-5)	°C/W
Junction-to-ambient Thermal Resistance	232 (DFN4L 1x1)	°C/W
Junction-to-case(top) Thermal Resistance	62 (SOT23-5)	°C/W
Junction-to-case(top) Thermal Resistance	86 (DFN4L 1x1)	°C/W
Power Dissipation	0.6 (SOT23-5)	W
Power Dissipation	0.6 (DFN4L 1x1)	W
Lead Temperature Soldering, 10Sec	260	°C

ESD RATINGS

Items	Description	Value	Unit
VESD_HBM	Human Body Model for all pins	±2000	V
VESD_CDM	Charged Device Model for all pins	±2000	V

JEDEC specification JS-001

RECOMMEND OPERATING CONDITIONS

Items	Description	Min	Max	Unit
Voltage Range	IN	2.5	5.5	V
T _J	Operation Junction Temperature	-40	125	°C
T _A	Operation Ambient Temperature	-40	85	°C

PIN CONFIGURATION

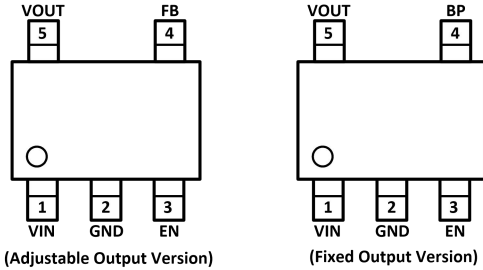
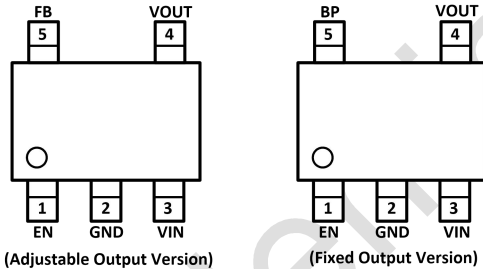
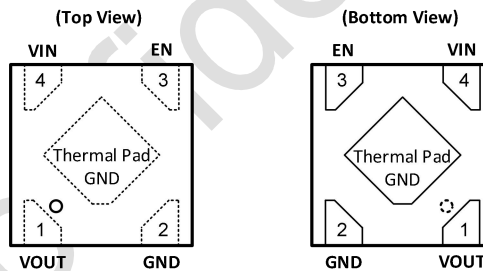
Package Type	Pin Configurations
TMI6030 / SOT23-5	
TMI6030B / SOT23-5	
TMI6030D / DFN4L 1x1	

PIN FUNCTIONS

TMI6030	TMI6030B	TMI6030D	Name	Function
1	3	4	VIN	Input Supply of the LDO.
2	2	2	GND	Signal Ground.
3	1	3	EN	Enable Pin. Connect this pin to ground or less than 0.4V to disable the device, connect EN to 1.5V or above to enable the device. This pin should not be floated.
4	5	NA	FB	Feedback Pin for adjustable output version
			BP	Bypass pin for fixed output version except 2.8V fixed output version. Bypass with a 10nF ceramic capacitor to reduce output noise or keep this pin floating.
			NC	No connection for TMI6030-28 with 2.8V fixed output.
5	4	1	VOUT	Output of the LDO

ORDER INFORMATION

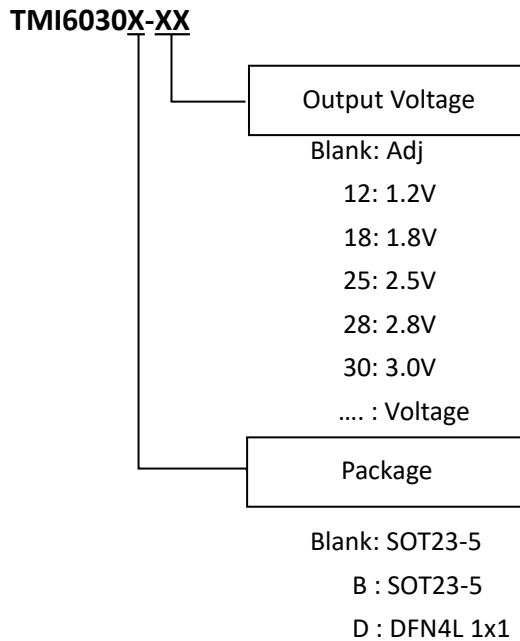

Part Number	Package	Top Mark	Quantity/ Reel
TMI6030	SOT23-5	TAAxxx	3000
TMI6030-12	SOT23-5	TABxxx	3000
TMI6030-15	SOT23-5	TAHxxx	3000
TMI6030-18	SOT23-5	TACxxx	3000
TMI6030-25	SOT23-5	TADxxx	3000
TMI6030-28	SOT23-5	TAExxx	3000
TMI6030-30	SOT23-5	TAFxxx	3000
TMI6030-33	SOT23-5	TAGxxx	3000
TMI6030B	SOT23-5	TBAxxx	3000
TMI6030B-12	SOT23-5	TBBxxx	3000
TMI6030B-15	SOT23-5	TBHxxx	3000
TMI6030B-18	SOT23-5	TBCxxx	3000
TMI6030B-25	SOT23-5	TBDxxx	3000
TMI6030B-28	SOT23-5	TBExxx	3000
TMI6030B-30	SOT23-5	TBFxxx	3000
TMI6030B-33	SOT23-5	TBGxxx	3000
TMI6030D-12	DFN4L 1x1	TDBxxx	10000
TMI6030D-15	DFN4L 1x1	TDHxxx	10000
TMI6030D-18	DFN4L 1x1	TDCxxx	10000
TMI6030D-25	DFN4L 1x1	TDDxxx	10000
TMI6030D-28	DFN4L 1x1	TDExxx	10000
TMI6030D-30	DFN4L 1x1	TDFxxx	10000
TMI6030D-33	DFN4L 1x1	TDGxxx	10000

Top Mark: TXXxxx (TXX: Device Code, xxx: Inside code)

ELECTRICAL CHARACTERISTICS

$T_A=25^{\circ}\text{C}$, $V_{IN}=V_{OUT}+1\text{V}$, or $V_{IN}=2.5\text{V}$ for $V_{OUT}<1.5\text{V}$ unless otherwise specified.

Symbol	Parameter	conditions	Min	Typ	Max	Unit
Input Voltage						
V_{IN}	Input Voltage Range		2.5		5.5	V
I_Q	Quiescent Current	$V_{EN}=2.5\text{V}$, $I_{OUT}=0\text{mA}$	35	50	70	μA
I_{SHDN}	Shutdown Current	$V_{EN}=0\text{V}$		0.1	1	μA
PSRR	Power Supply Ripple Rejection	$V_{IN}=V_{nom}+1V_{P-P}$, $f=1\text{kHz}$, $I_{LOAD}=10\text{mA}$ BP is floating		70		dB
Enable						
V_{ENH}	Enable High Voltage	All temperature range	1.5			V
V_{ENL}	Enable Low Voltage	All temperature range			0.4	V
I_{EN}	EN Input Current	$V_{IN}=3.5\text{V}$, $V_{EN}=3.5\text{V}$ or 0V	-1	0.2	1	μA
T_{ST}	Start-up Time	$V_{IN}=3.5\text{V}$, $V_{OUT}=2.5\text{V}$		40		μs
Output Voltage						
V_{OUT}	Output Voltage Accuracy	$V_{IN}=V_{OUT}+1\text{V}$, $I_{OUT}=10\text{mA}$	-2		+2	%
		$V_{IN}=V_{OUT}+1\text{V}$, $I_{OUT}=10\text{mA}$, $T_A=-40^{\circ}\text{C}$ to $+85^{\circ}\text{C}$	-3		+3	%
V_{FB}	FB Pin Voltage		1.176	1.2	1.224	V
V_{LNR}	Output Line Regulation	$V_{OUT}+0.5\text{V}<V_{IN}<5.5\text{V}$, $I_{OUT}=10\text{mA}$		0.01	0.1	%/V
V_{LDR}	Output Load Regulation	$1\text{mA}<I_{OUT}<300\text{mA}$, $V_{IN}=V_{NOM}+1.0\text{V}$		3		mV
V_{DROP}	Dropout Voltage (Note 1)	$I_{OUT}=300\text{mA}$		320	350	mV
I_{OUTMAX}	Maximum Output Current		300			mA
Protection						
I_{limit}	Current Limit		450	600		mA
I_{short}	Output Short Current Limit	V_{FB} or $V_{OUT}=0\text{V}$	110			mA
R_{AD}	Resistance of Auto-Discharge			130		Ω
T_{SD}	Thermal Shutdown Temperature (Note 2)	No Load, $V_{IN}=V_{EN}=5\text{V}$		160		$^{\circ}\text{C}$
T_{SDHYS}	Thermal Shutdown Hysteresis (Note 2)	No Load, $V_{IN}=V_{EN}=5\text{V}$		20		$^{\circ}\text{C}$

Note 1: Dropout is defined as $V_{IN}-V_{OUT}$ when V_{OUT} is 2% below the value of V_{OUT} for $V_{IN}=V_{OUT}+0.5\text{V}$.

Note 2: Thermal shutdown threshold and hysteresis are guaranteed by design.

TYPICAL PERFORMANCE CHARACTERISTICS

Load Transient

Vin=3.8V, Vo=2.8V, Io=10mA to 300mA

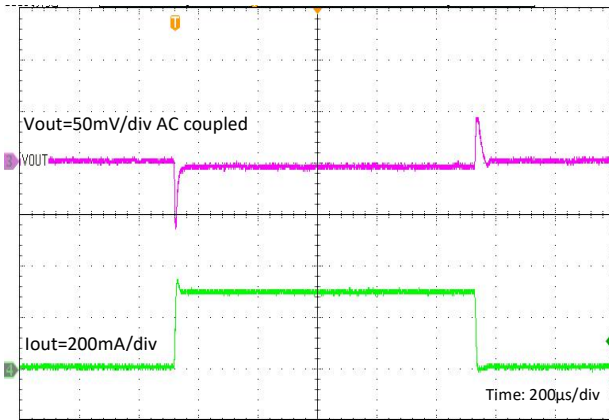

Line Transient

Vo=2.8V, Io=10mA, Vin=3.3V to 4.3V

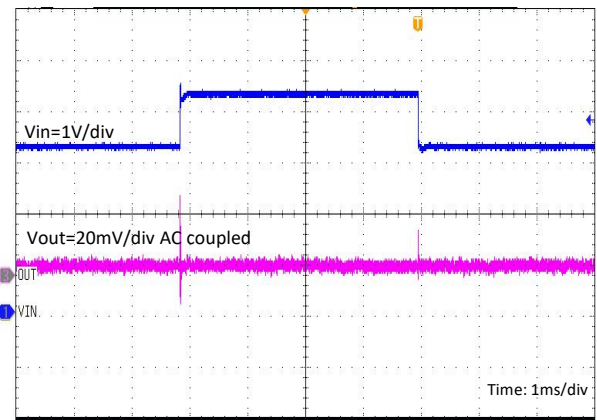

Over Temperature Protection

Vin=3.8V, Vo=2.8V, Ro=5.1Ω

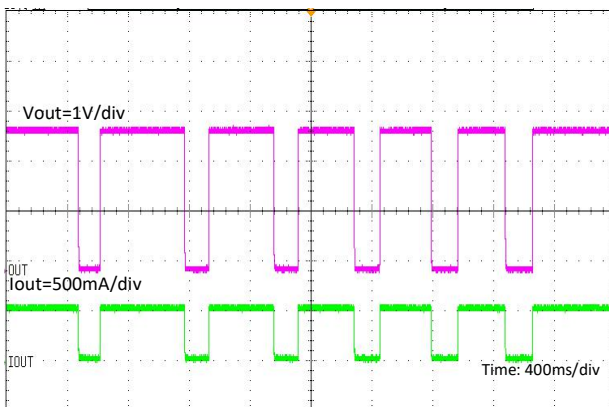

Start Up

Vin=3.5V, Vo=2.5V, Ta=25°C

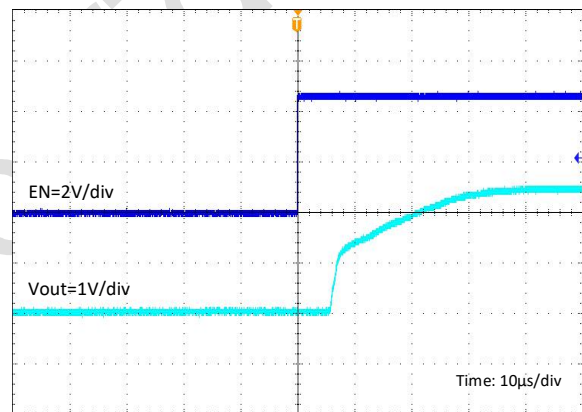

PSRR vs Frequency

Vin=2.5V, Vo=1.5V, Io=10mA, Ta=25°C

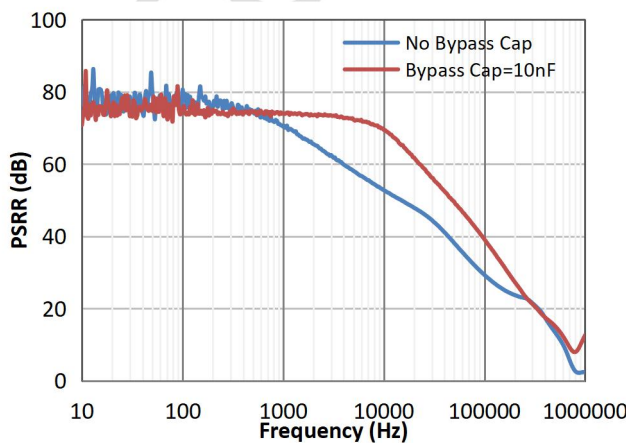

PSRR vs Frequency

Vin=3.8V, Vo=2.8V, Io=10mA, Ta=25°C

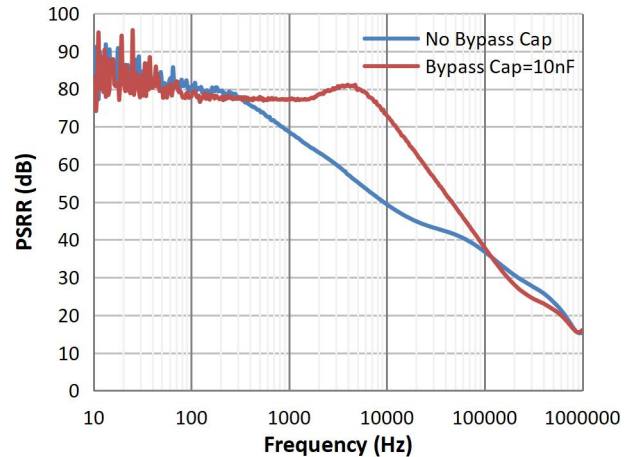

TYPICAL PERFORMANCE CHARACTERISTICS (Continued)

Output Voltage vs Output Current

$V_o=2.5V, T_a=25^{\circ}C$

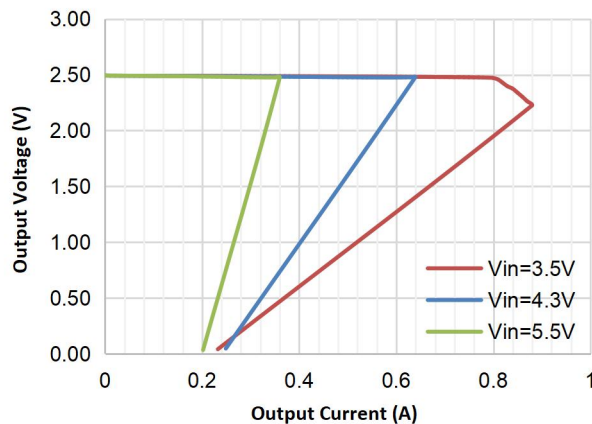

Dropout vs. Iout

$V_{in}=3.8V, T_a=25^{\circ}C$

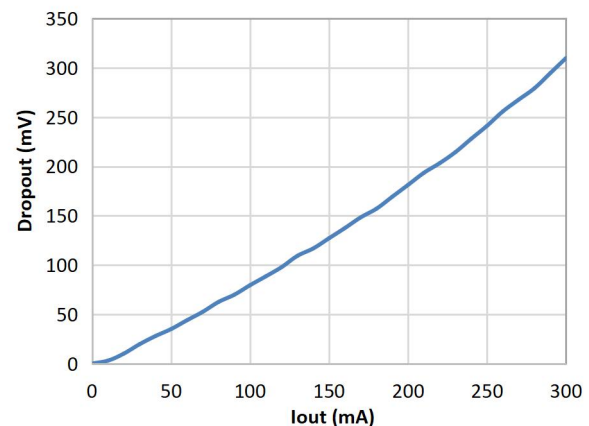

Detailed Function Description

The TMI6030 is a 300mA output current, low dropout linear regulator with fast transient response and high PSRR. It offers high output accuracy, low quiescent current and fast start-up time. It is designed to work with low-ESR ceramic capacitor, reducing the amount of the PCB area. Only a 1μF ceramic output capacitor can make the device stable over the whole load range.

As shown in the function block diagram, the TMI6030 is composed of the bandgap reference voltage, the error amplifier, P-channel MOSFET pass transistor, external resistor divider and some additional protection circuits. The reference voltage, connected to the cathode terminal of the error amplifier, compares with the feedback voltage to regulate the output voltage to make it constant over the whole load current range. If the feedback voltage is lower than the reference voltage, the pass transistor gate is pulled lower to increase its conductivity. This allows more current to flow to the output and increase the output voltage. If the feedback voltage is higher than the reference voltage, the pass transistor gate is pulled higher to decrease its conductivity. This allows less current to flow to the output and decrease the output voltage. The feedback point is the output of the external resistor divider connected to the V_{OUT} pin.

Enable/Shutdown

The TMI6030 is disabled when the EN pin is connected to ground or the voltage less than 0.4V, and the quiescent current is less than 1μA. Connect EN pin to 1.5V or higher voltage to enable the device. This pin cannot be floated.

Output Auto Discharge

When the regulator is disabled, an internal 130Ω resistor is connected between V_{OUT} and GND to discharge output capacitor C_{OUT}.

Current Limit

The TMI6030 includes a current limit circuit to monitor the gate voltage of the pass transistor to limit the output current. When the output current is higher than the over-current limit, the circuit will clamp the gate voltage of the pass transistor to limit the output current. The current limit is larger than 450mA and the typical output current limit value is 600mA.

Adjustable Output Voltage

The adjustable version TMI6030 has a wide output voltage range. The output voltage is programmed by an external resistor divider as shown in Figure 1. The output can be calculated by the following equation:

$$V_{OUT} = \left(1 + \frac{R_1}{R_2}\right) \times V_{REF} \quad (\text{EQ.1})$$

Where V_{REF} is the internal reference voltage, which is 1.2V in TMI6030.

Short Circuit Protection

When V_{OUT} pin is short-circuit to GND, short circuit protection will be triggered and clamp the output current to output current short limit that is larger than 110mA. This feature protects the regulator from over current condition and damage due to overheating.

Thermal Shutdown

The TMI6030 monitors internal temperature. When the junction temperature exceeds 160°C, the over temperature protection (OTP) circuit turn off the pass transistor until the device is cooled down by 20°C. Then the pass transistor resumes. For continue operation, do not exceed absolute maximum junction temperature.

Application Information

External capacitor

The TMI6030 requires external capacitor for stability. It is specifically designed to work with low-ESR capacitors requiring minimum PCB area. Place the external capacitors as close as possible to the device.

Input capacitor

A 1 μ F or higher capacitance value ceramic capacitor is required between the VIN pin and the GND pin. Place it as close as possible to the device. There are no requirements for the ESR on the input capacitor, but the tolerance and temperature coefficient must be considered. The ceramic capacitor with 1 μ F or larger rating capacitance, X5R or X7R type dielectrics and 0402 or larger size is recommended as input capacitor.

Output capacitor

An output capacitor (C_{OUT}) is needed to improve transient response and maintain stability. The TMI6030 is stable with very small ceramic output capacitors. A 1 μ F to 10 μ F capacitor is suitable for the most TMI6030 applications. For typical application, the ceramic capacitor with 1 μ F or larger rating capacitance, X5R or X7R type dielectrics and 0402 or larger size is recommended as output capacitor.

Bypass capacitor

A ceramic bypass capacitor (C_{BP}) can be used to improve output noise performance and PSRR Performance.
If there is no bypass capacitor needed, please keep BP pin floating.

TOLL Confidential

PACKAGE INFORMATION

SOT23-5

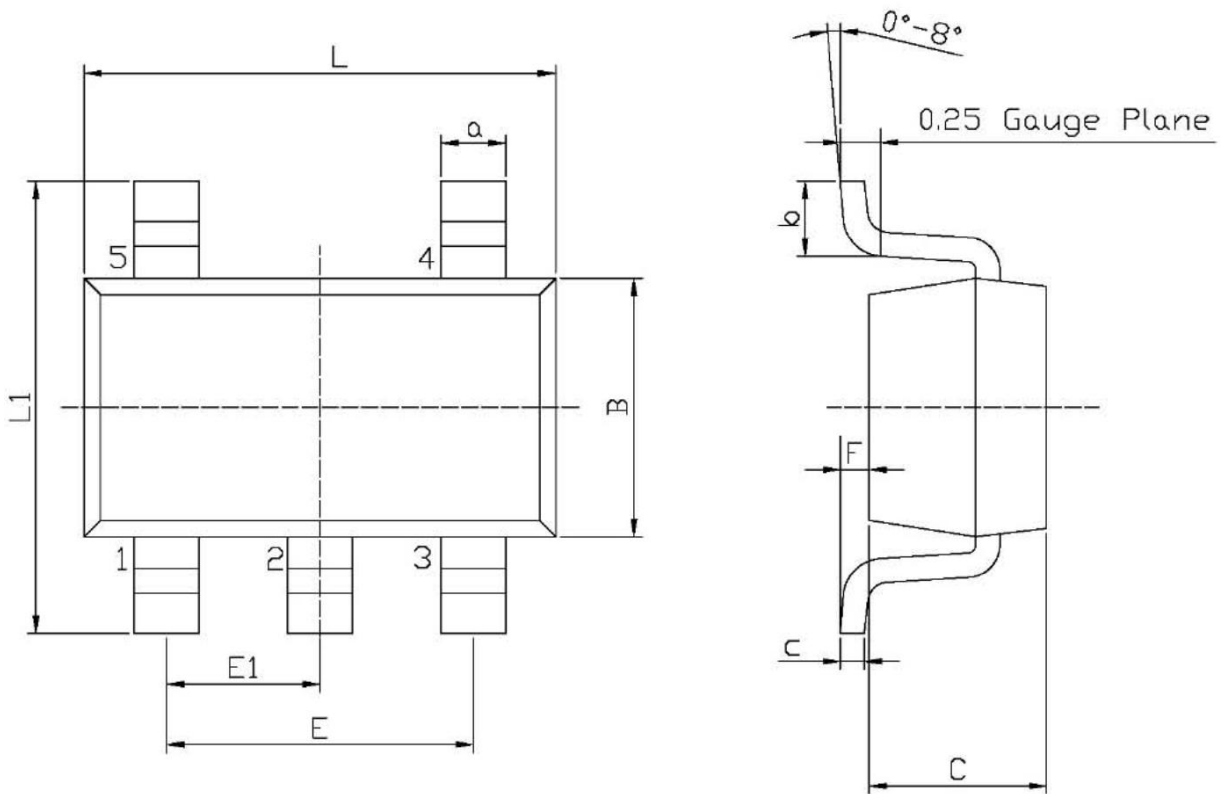

Unit: mm

Symbol	Dimensions In Millimeters		Symbol	Dimensions In Millimeters	
	Min	Max		Min	Max
L	2.82	3.02	E1	0.85	1.05
B	1.50	1.70	a	0.35	0.50
C	0.90	1.30	c	0.10	0.20
L1	2.60	3.00	b	0.35	0.55
E	1.80	2.00	F	0	0.15

Note:

- 1) All dimensions are in millimeters.
- 2) Package length does not include mold flash, protrusion or gate burr.
- 3) Package width does not include inter lead flash or protrusion.
- 4) Lead popularity (bottom of leads after forming) shall be 0.10 millimeters max.
- 5) Pin 1 is lower left pin when reading top mark from left to right.

TAPE AND REEL INFORMATION

TAPE DIMENSIONS: SOT23-5

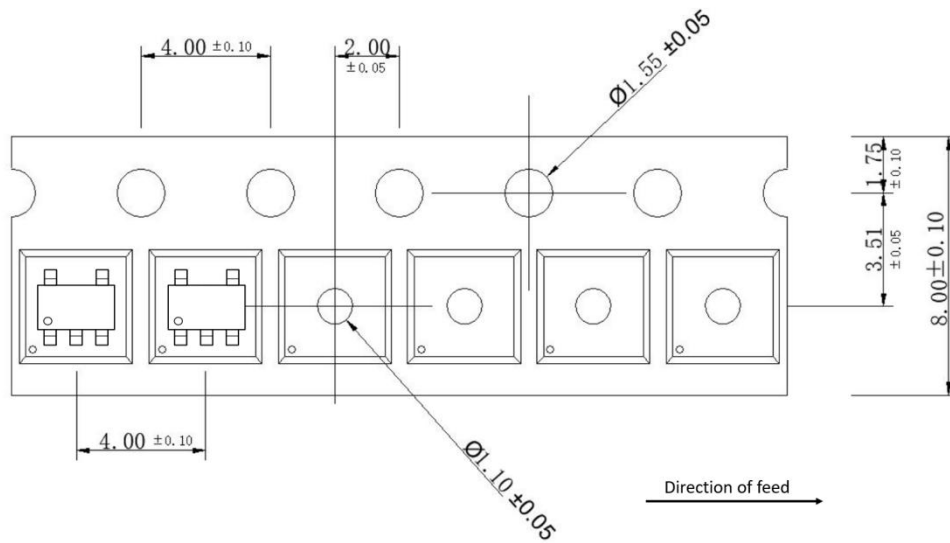

REEL DIMENSIONS: SOT23-5

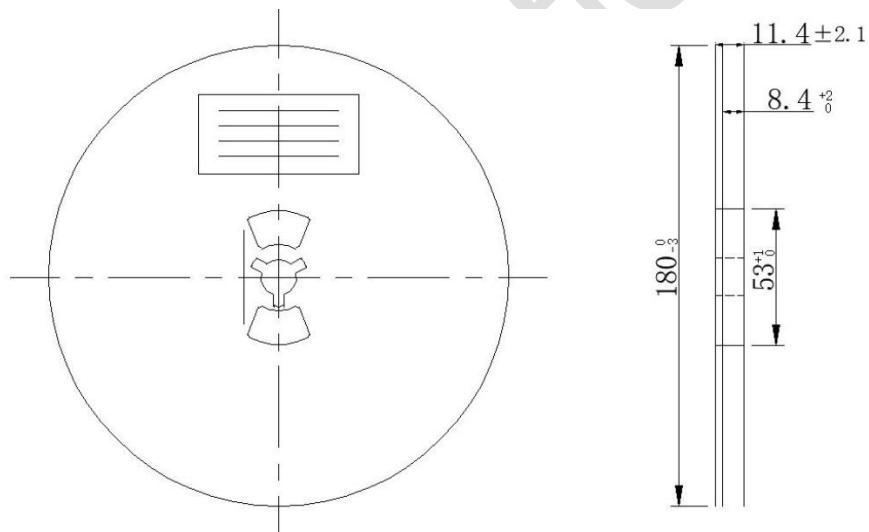

Note:

- 1) All Dimensions are in Millimeter
- 2) Quantity of Units per Reel is 3000
- 3) MSL level is level 3.

PACKAGE INFORMATION

DFN4L 1x1

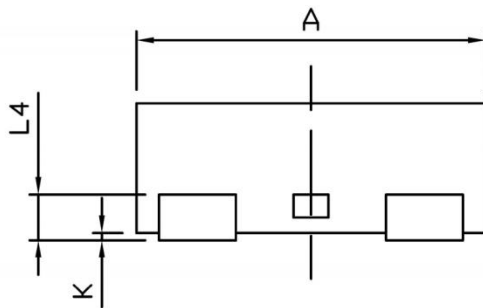
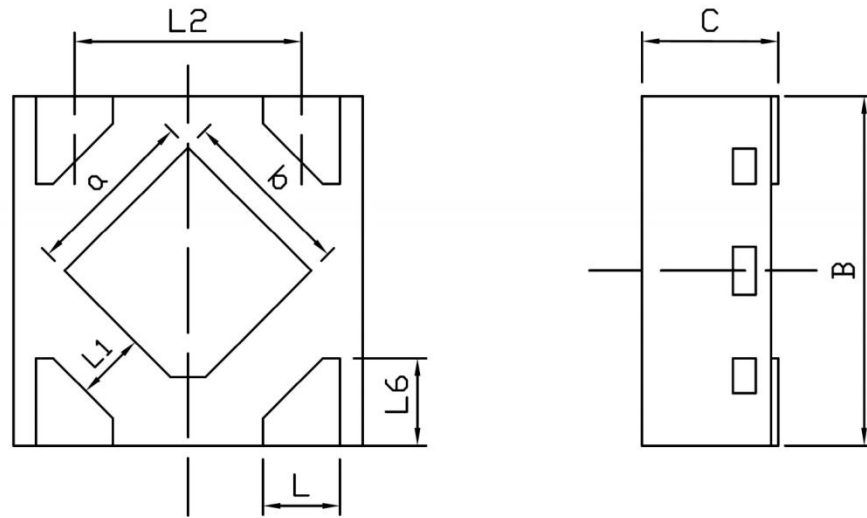

Unit: mm

Symbol	Dimensions In Millimeters			Symbol	Dimensions In Millimeters		
	MIN	TYP	MAX		MIN	TYP	MAX
A	0.950	1.000	1.050	L4	-	0.100	-
B	0.950	1.000	1.050	L6	0.200	0.250	0.300
C	0.340	0.370	0.400	K	0.000	0.020	0.050
L	0.170	0.220	0.270	a	0.430	0.480	0.530
L1	0.150	-	-	b	0.430	0.480	0.530
L2	-	0.650	-				

Note:

1) All dimensions are in millimeters.

TAPE AND REEL INFORMATION

TAPE DIMENSIONS: DFN4L 1x1

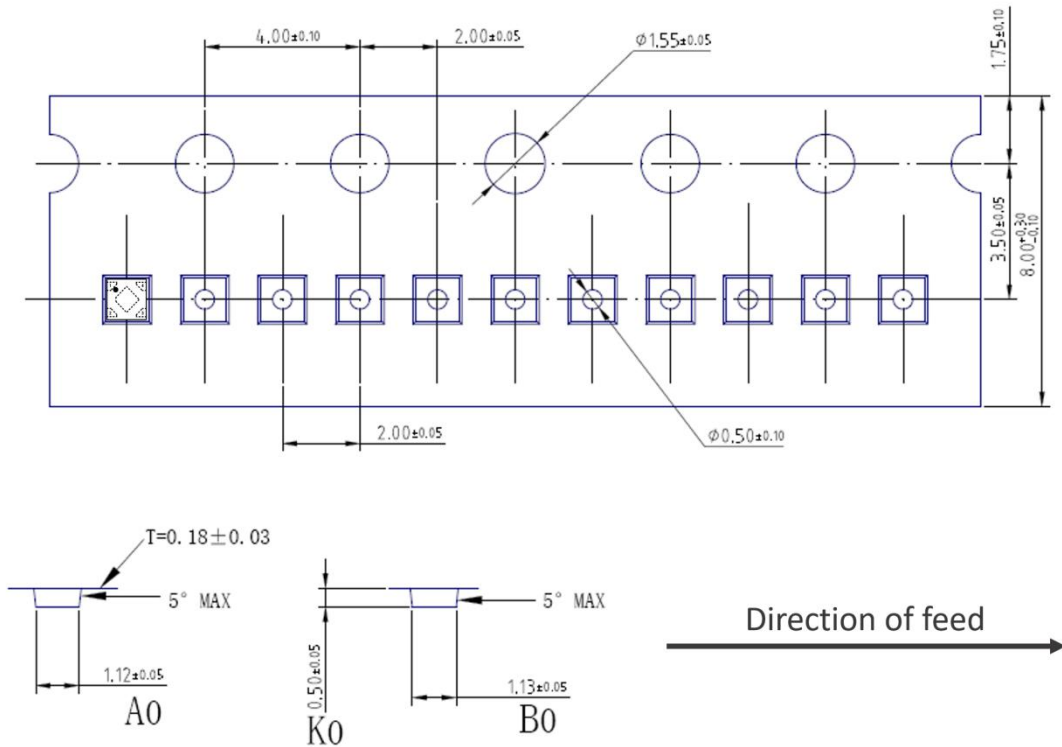

REEL DIMENSIONS: DFN4L 1x1

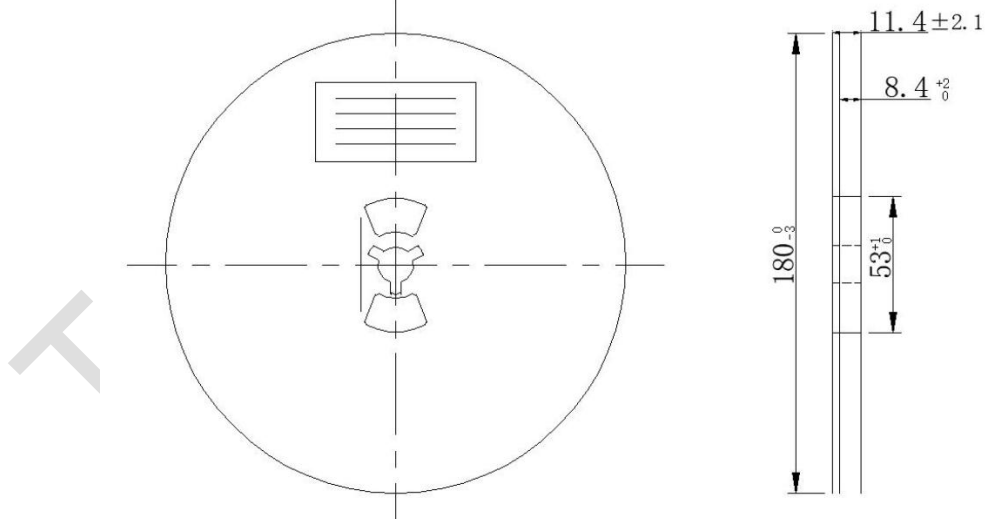

Note:

- 4) All Dimensions are in Millimeter
- 5) Quantity of Units per Reel is 10000
- 6) MSL level is level 3.