

30V 1MHz High Efficiency Boost LED Drive

FEATURES

- High Efficiency: Up to 90%
- 1.0MHz Constant Frequency Operation
- On Board Power MOSFET
- Drives up to 7 Series WLEDs
- Low 200mV Feedback Voltage
- Soft-start/Dimming with wide Frequency Range
- UVLO, Thermal Shutdown
- Internal Current limit
- Over Voltage Protection
- Small LC Filter
- Minimize the External Component
- <1 μ A Shutdown Current
- Tiny SOT23-6 Package

APPLICATIONS

- Camera Flash White LED
- Mobile Phone, Smart Phone LED Backlight
- PDA LED Back light
- Digital Still Cameras
- Camcorder

APPILICATIONS

GENERAL DESCRIPTION

The STI9287 is a step-up converter designed for driving up to 7 series white LED's from a single cell Lithium Ion battery. The STI9287 uses current mode, fixed frequency architecture to regulate an LED current, which is measured through an external current sense resistor. Its low 200mV feedback voltage reduces power loss and improves efficiency.

The STI9287 includes under-voltage lockout, current limiting and thermal overload protection preventing damage in the event of an output overload.

Optimized operation frequency can meet the requirement of small LC filters value and low operation current with high efficiency. Internal soft start function can reduce the inrush current. Tiny package type provides the best solution for PCB space saving and total BOM cost.

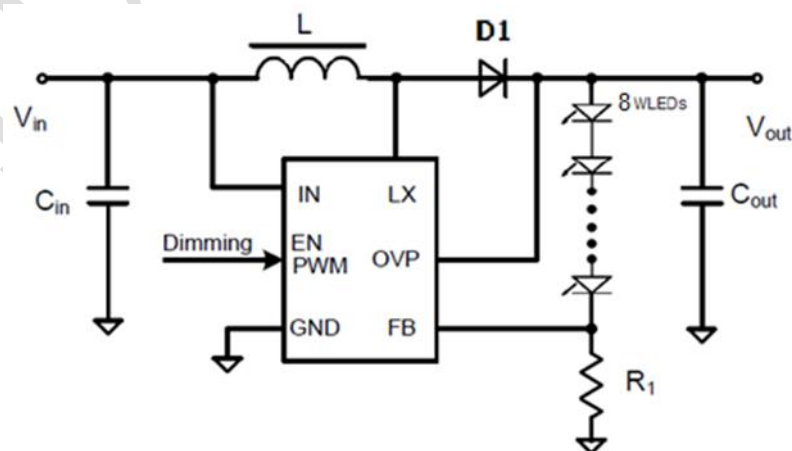
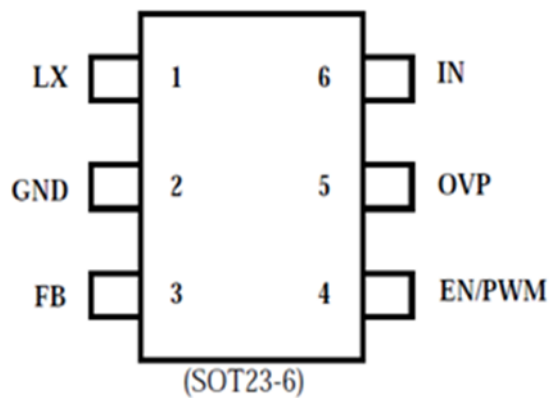

Figure 1. Basic Application Circuit

ABSOLUTE MAXIMUM RATINGS (Note1)

Parameter	Value	Unit
Input Supply voltage	-0.3 ~ 25	V
LX voltage	-0.3 ~ 25	V
EN voltage	-0.3 ~ 25	V
Junction Temperature(Note2)	125	°C
Power Dissipation	600	mW
Storage Temperature Range	-65~150	°C
Lead Temperature(Soldering,10s)	260	°C

PACKAGE/ORDER INFORMATION



SOT23-6

Top Mark: S87XXX (S87: Device Code, XXX: Inside Code)

Part Number	Package	Top mark	Quantity/ Reel
STI9287	SOT23-6	S87XXX	3000

PIN DESCRIPTIONS

Pin	Name	Function
1	LX/SW	Power Switch Output. It is the switch node connection to Conduction.
2	GND	Ground Pin
3	FB	Output Voltage Feedback Pin.
4	EN	Chip Enable Pin. Drive EN above 1.5V to turn on the part. Drive EN below 0.4V to turn it off. Do not leave EN floating.
5	OVP	Over Voltage Input. OV measures the output voltage for open circuit protection. Connect OV to the output at the top of the LED string.
6	IN	Power Supply Input. Must be closely decoupled to GND with a 1 μ F or greater ceramic capacitor.

ESD RATING

Items	Description	Value	Unit
V _{ESD}	Human Body Model for all pins	\pm 2000	V

JEDEC specification JS-001
RECOMMENDED OPERATING CONDITIONS

Items	Description	Min	Max	Unit
Voltage Range	IN	2.5	24	V
TA	Operating Temperature Range	-40	85	$^{\circ}$ C

ELECTRICAL CHARACTERISTICS (Note3)

($V_{IN}=V_{EN}=3.7V, T_A = 25^{\circ}C$, unless otherwise noted.)

Parameter	Conditions	Min	Typ	Max	Unit
Input Voltage Range		2.5		24	V
UVLO Threshold			2.2		V
Under Voltage Lockout Hysteresis			100		mV
Shutdown Current	$V_{EN}<0.4V$		0.1	1	μA
Quiescent Current	$V_{FB}=0.15V$, No switch		200	300	μA
Supply Current	$V_{FB}=0V$, switch		0.6	1	mA
Regulated Feedback Voltage			200		mV
Oscillation Frequency			1.0		MHz
ON Resistance of NMOS			0.2		Ω
Peak Current Limit	$V_{IN}= 4.2V$, Duty cycle=50%	1.2		1.7	A
EN Shutdown Voltage				0.4	V
EN Enable Voltage		1.5			V
EN Leakage Current			± 0.01	± 1.0	μA
OVP Threshold	Vov Rising		30		V

Note 1: Absolute Maximum Ratings are those values beyond which the life of a device may be impaired.

Note 2: T_J is calculated from the ambient temperature T_A and power dissipation P_D according to the following formula: $T_J = T_A + (P_D) \times (250^{\circ}C/W)$.

Note3: 100% production test at $+25^{\circ}C$. Specifications over the temperature range are guaranteed by design and characterization.

Note 4: Dynamic supply current is higher due to the gate charge being delivered at the switching frequency

OPERATION

The STI9287 uses a constant frequency, peak current mode boost regulator architecture to regulate the series string of white LEDs. At the start of each oscillator cycle the FET is turned on through the control circuitry. To prevent sub-harmonic oscillations at duty cycles greater than 50 percent, a stabilizing ramp is added to the output of the current sense amplifier and the result is fed into the positive input of the PWM comparator. When this voltage equals the output voltage of the error amplifier the power FET is turned off. The voltage at the output of the error amplifier is an amplified version of the difference between the 250mV reference voltage and the feedback voltage. In this way the peak current level keeps the output in regulation. If the feedback voltage starts to drop, the output of the error amplifier increases. This results in more current flowing through the power FET, thus increasing the power delivered to the output.

FUNCTIONAL BLOCK DIAGRAM

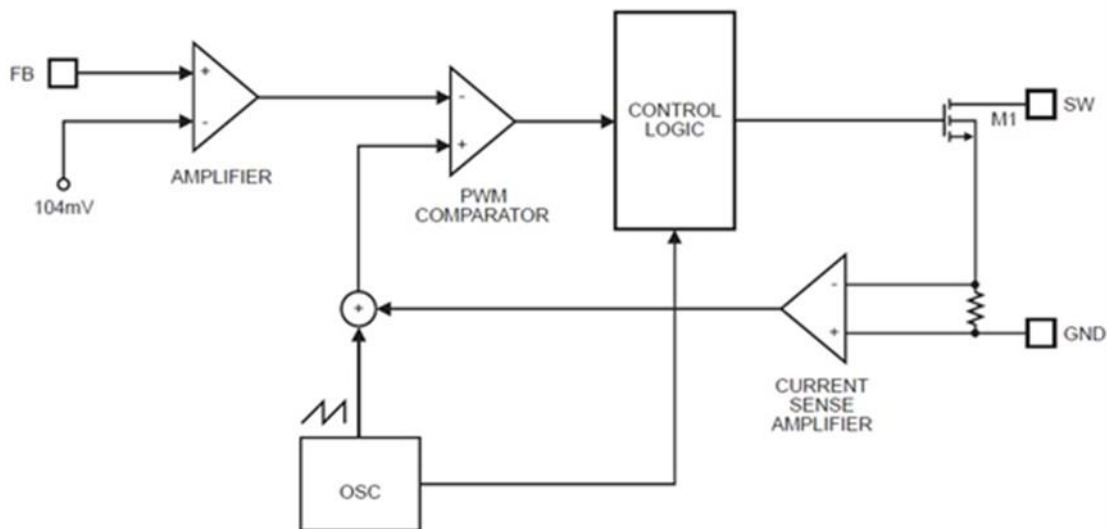

Figure 2. STI9287 Block Diagram

APPLICATION INFORMATION

Setting the LED current

The LED current is controlled by the feedback resistor, R1, in Figure 4. The current through the LEDs is given by the equation $200\text{mV}/R1$. Table 1 shows the selection of resistors for a given LED current.

Table 1— I_{LED} VS. R1

$I_{\text{LED}}(\text{mA})$	$R1(\Omega)$
1	200
5	40
10	20
15	13.3
20	10

Dimming Control

a. Using a PWM Signal to EN Pin

For controlling the LED brightness, the STI9287 can perform the dimming control by applying a PWM signal to EN pin. The internal soft start and the wide range dimming frequency can eliminate inrush current and audio noise when dimming. The average LED current is proportional to the PWM signal duty cycle. The magnitude of the PWM signal should be higher than the maximum enable voltage of EN pin, in order to let the dimming control perform correctly for preventing the flicker issue, the suggested PWM frequency is $\geq 1\text{kHz}$ or $\leq 200\text{Hz}$.

b. Using a DC Voltage

Using a variable DC voltage to adjust the brightness is a popular method in some applications. According to the Superposition Theorem, as the DC voltage increases, the voltage contributed to VFB increases and the voltage drop on R2 decreases, i.e. the LED current decreases. For example, if the VDC range is from 0V to 2.8V, the selection of resistors sets dimming control of LED current from 20mA to 0mA.

c. Using a Filtered PWM signal

Another common application is using a filtered PWM signal as an adjustable DC voltage for LED dimming control. A filtered PWM signal acts as the DC voltage to regulate the output current. In this circuit, the output ripple depends on the frequency of PWM signal. For smaller output voltage ripple ($< 100\text{mV}$), the recommended frequency of 2.8V PWM signal should be above 2kHz. To fix the frequency of PWM signal and change the duty cycle of PWM signal can get different output current.

Inductor Selection

The recommended value of inductor is 4.7 to 22μH. Small size and better efficiency are the major concerns for portable device, such as STI9287 used for mobile phone. The inductor should have low core loss at 1.0MHz and low DCR for better efficiency. To avoid inductor saturation current rating should be considered.

Capacitor Selection

Input and output ceramic capacitors of 1μF are recommended for STI9287 applications. For better voltage filtering, ceramic capacitors with low ESR are recommended. X5R and X7R types are suitable because of their wider voltage and temperature ranges.

Diode Selection

Schottky diode is a good choice for STI9287 because of its low forward voltage drop and fast reverse recovery. Using Schottky diode can get better efficiency. The high speed rectification is also a good characteristic of Schottky diode for high switching frequency. Current rating of the diode must meet the root mean square of the peak current and output average current multiplication as following:

$$I_D(\text{RMS}) \approx \sqrt{I_{\text{OUT}} \times I_{\text{PEAK}}}$$

The diode's reverse breakdown voltage should be larger than the output voltage.

Layout Consideration

For best performance of the STI9287, the following guide lines must be strictly followed.

- Input and Output capacitors should be placed close to the IC and connected to ground plane to reduce noise coupling.
- The GND and Exposed Pad should be connected to a strong ground plane for heat sinking and noise protection.
- Keep the main current traces as possible as short and wide.
- LX node of DC-DC converter is with high frequency voltage swing. It should be kept at a small area.
- Place the feedback components as close as possible to the IC and keep away from the noisy devices.

PACKAGE INFORMATION

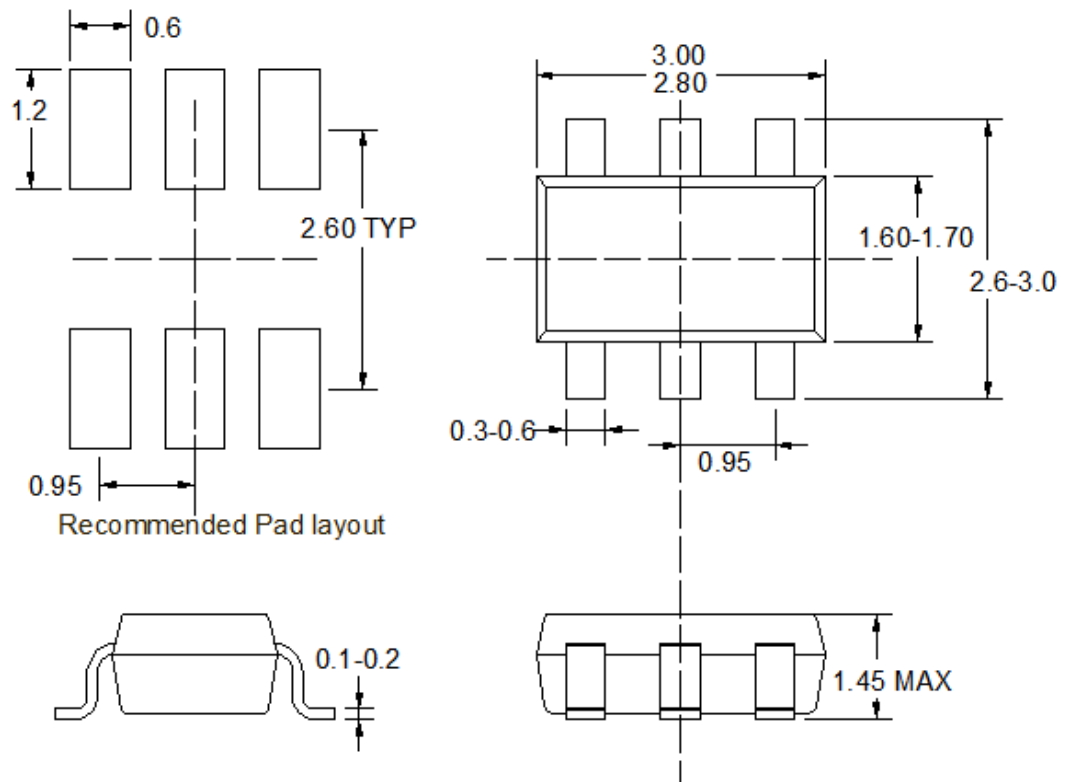

SOT23-6

Note:

- 1) All dimensions are in millimeters.
- 2) Package length does not include mold flash, protrusion or gate burr.
- 3) Package width does not include inter lead flash or protrusion.
- 4) Lead popularity (bottom of leads after forming) shall be 0.10 millimeters max.
- 5) Pin 1 is lower left pin when reading top mark from left to right.