

| GENERAL TOLERANCE | | | | | | | | | | USED ON |
|-------------------|--------|--------|--------|---------|---------|---------|---------|-------|--------|---------|
| 10 MAX | 30 MAX | 50 MAX | 70 MAX | 100 MAX | 120 MAX | 250 MAX | 250 OVR | ANGLE | ECCENT | |
| ±0.15 | ±0.20 | ±0.30 | ±0.40 | ±0.50 | ±0.75 | ±0.90 | ±1.4 | ±0.5° | 0.1 | |

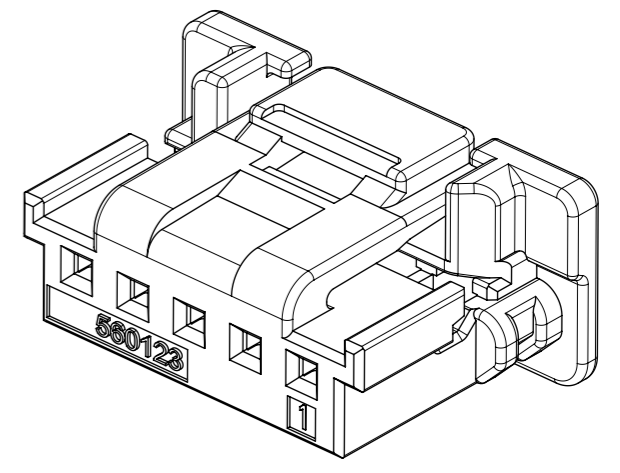

ISO VIEW

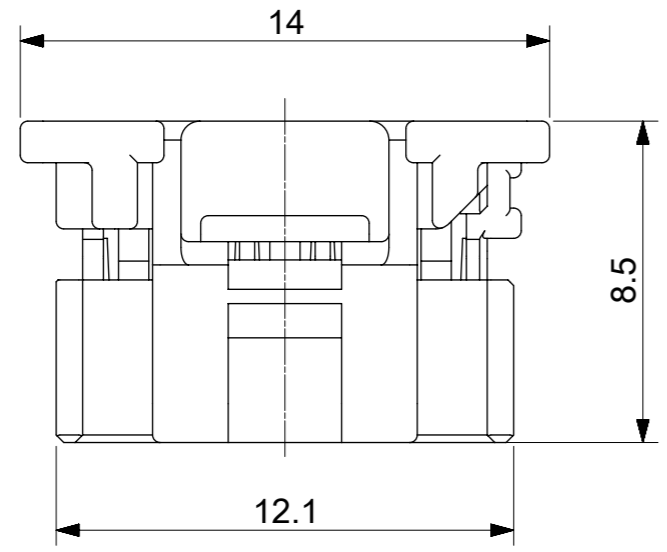
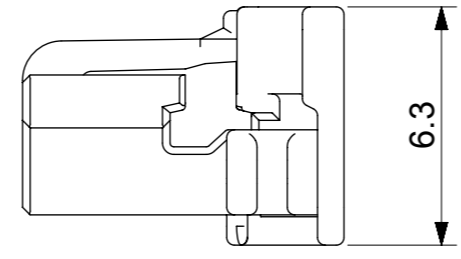
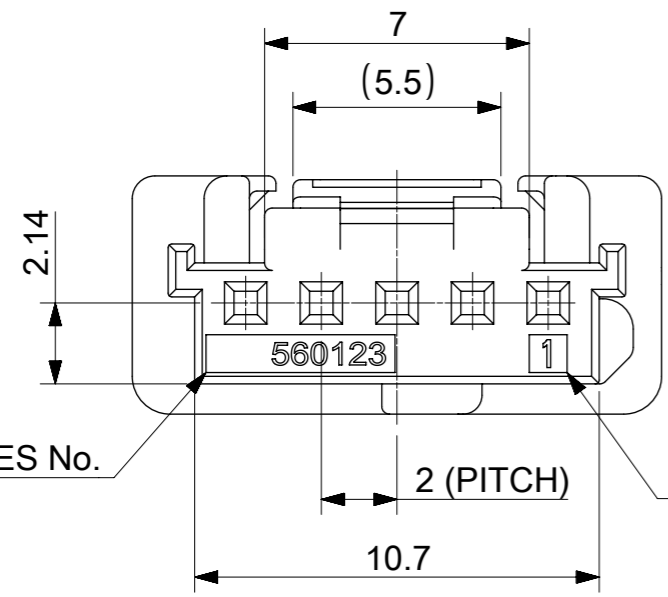

CIRCUIT No.

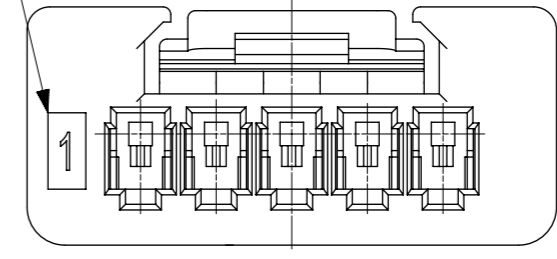

NOTES:

1. MATERIAL: POLYESTER(PBT), GLASS FILLES, UL94V-0
COLOR: SEE TABLE
2. MATES WITH: 502352, 560020 SERIES
3. APPLICABLE TERMINAL: 560124-0101,560124-0131
4. APPLICABLE ISL: 560125-0500
5. GENERAL TOLERANCE: SEE TABLE
6. ELV AND RoHS COMPLIANT

| ORDER NO | MATERIAL NO | COLOR |
|---------------|-------------|-------|
| 560123 - 0500 | 5601230500 | WHITE |
| 560123 - 0501 | 5601230501 | BLACK |

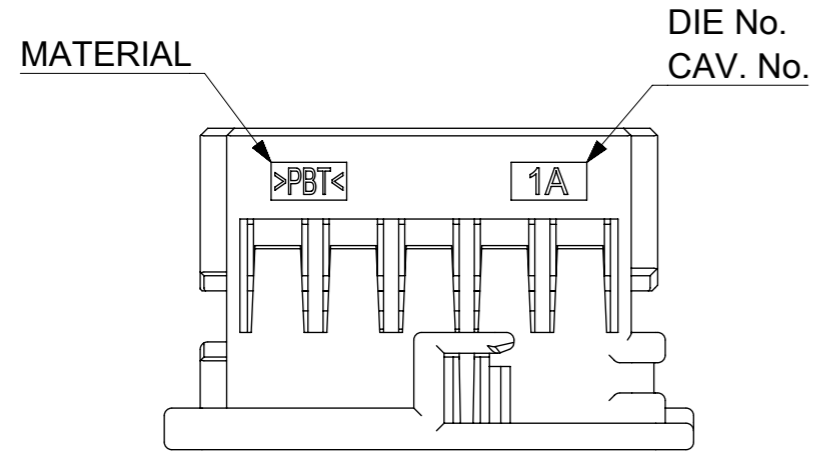

| | | | | | | | | |
|--|---|--|--|---|-----------------------------------|---|--|---|
| QUALITY SYMBOLS FA = 0 FE = 0 FB = 0 FV = 0 FC = 0 FX = 0 FS = 0 FT = 0 | THIS DRAWING CONTAINS INFORMATION THAT IS PROPRIETARY TO MOLEX ELECTRONIC TECHNOLOGIES, LLC AND SHOULD NOT BE USED WITHOUT WRITTEN PERMISSION | | | | DIMENSION UNITS: MM SCALE: 5:1 | | | |
| | EC NO: 109128 DRWN: SWYOON CHK'D: BCYOON APPR: JHJANG | 2016/10/07 2016/10/07 2016/10/18 | GENERAL TOLERANCES (UNLESS SPECIFIED) ANGULAR TOL ± ° | | DRWN BY: SWYOON | DATE: 2016/10/07 | | NEW 2.0 PITCH W/B CONN. REC. 5WAY HSG DURACLIC ISL SERIES |
| | | | 4 PLACES ± | 3 PLACES ± | CHK'D BY: BCYOON | DATE: 2016/10/07 | | |
| | | | 2 PLACES ± | 1 PLACE ± | APPR BY: | DATE: | | |
| DRAFT WHERE APPLICABLE MUST REMAIN WITHIN DIMENSIONS | | DRAWING SIZE: A3 | THIRD ANGLE PROJECTION | | PRODUCT CUSTOMER DRAWING | | | |
| | | | | SERIES: 560123 MATERIAL NUMBER: SEE TABLE CUSTOMER: | | DOCUMENT NUMBER: 5601230501 DOC TYPE: PSD DOC PART: 003 SHEET NUMBER: 1 OF 1 | | |