

ORDER NO.	WOODHEAD NO.	COLOR
130147-0047	27W47MB	YELLOW

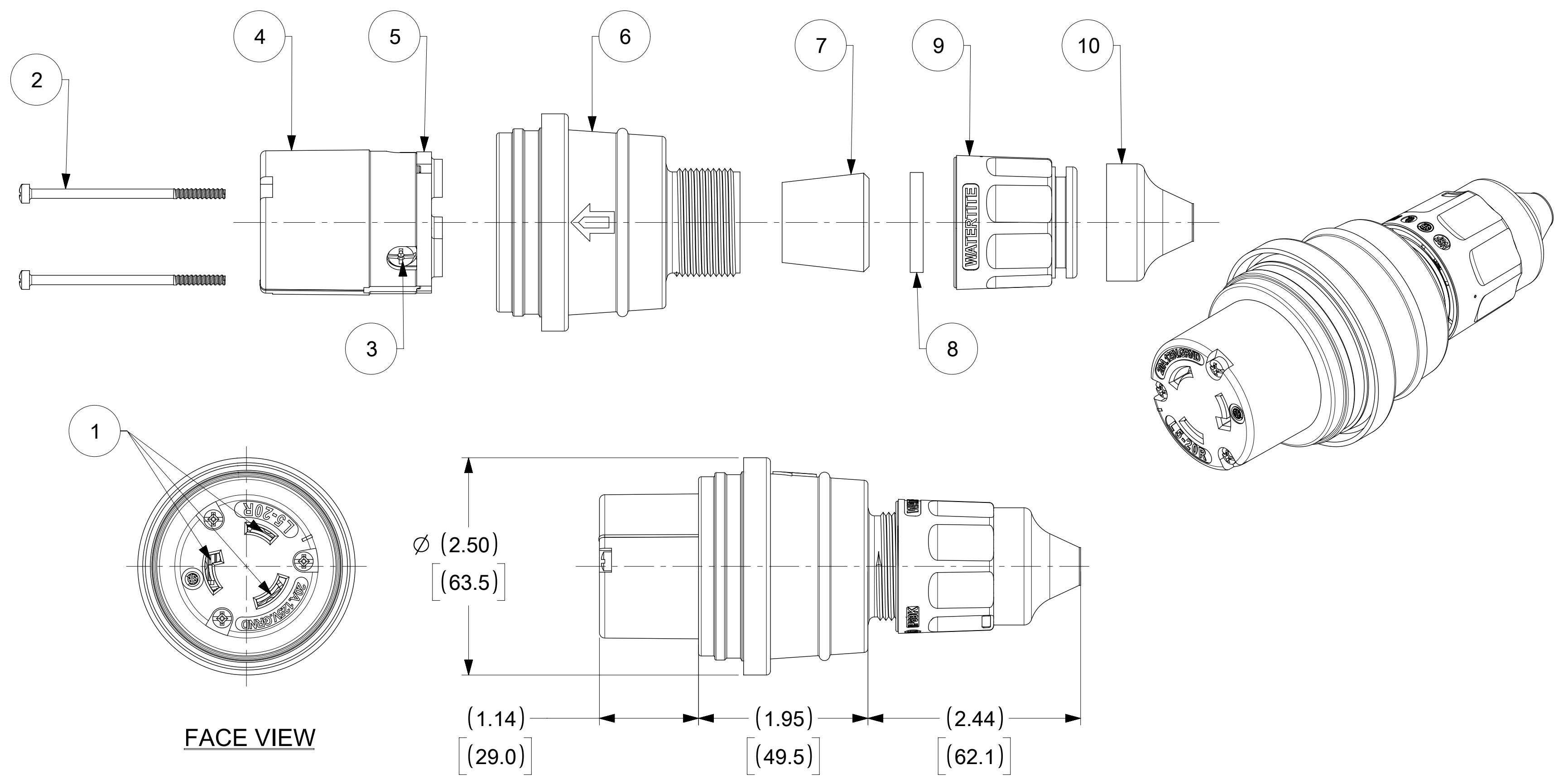

ITEM NO.	DESCRIPTIONS	MATERIAL	QTY.
1	BLADE	BRASS, NICKEL PLATED	3
2	RETAINING SCREWS	STAINLESS STEEL	3
3	CLAMP AND TERMINAL SCREW ASSY	BRASS, ZINC PLATED	3
4	INSERT	NYLON	1
5	TERMINAL COVER	POLYCARBONATE	1
6	HOUSING	SILICON WITH NYLON THREAD	1
7	GROMMET	RUBBER	4
8	FRICTION RING	NYLON	1
9	COMPRESSION NUT	NYLON	1
10	WITCHES HAT	SILICON RUBBER	1

SYMBOLS		THIS DRAWING CONTAINS INFORMATION THAT IS PROPRIETARY TO MOLEX ELECTRONIC TECHNOLOGIES, LLC AND SHOULD NOT BE USED WITHOUT WRITTEN PERMISSION	
▽ = 0	DIMENSION UNITS	SCALE	CURRENT REV DESC: RELEASED
▽ = 0	INCH[MM]	NTS	
▽ = 0	GENERAL TOLERANCES (UNLESS SPECIFIED)		
▽ = 0		MM	INCH
▽ = 0	4 PLACES	±	±
▽ = 0	3 PLACES	±	±
▽ = 0	2 PLACES	±	±
▽ = 0	1 PLACE	±	±
▽ = 0	0 PLACES	±	±
▽ = 0	ANGULAR TOL	± °	
▽ = 0	DRAFT WHERE APPLICABLE MUST REMAIN WITHIN DIMENSIONS		THIRD ANGLE PROJECTION
		DRAWING	SERIES
		C-SIZE	130147
		EC NO: 616447	
		DRWN: DSOPPIN	2019/01/11
		CHK'D: DNGUYEN62	2019/05/08
		APPR: HKNEELAND	2019/05/09
		INITIAL REVISION:	
		DRWN: DSOPPIN	2019/01/11
		APPR: HKNEELAND	2019/05/09
		DOCUMENT NUMBER	
		1301470047	
		DOC TYPE	DOC PART
		PSD	000
		REVISION	
		A	
		MATERIAL NUMBER	CUSTOMER
		SEE TABLE	GENERAL MARKET
		SHEET NUMBER	
		1 OF 1	