

ORDER NO.	WOODHEAD NO.	COLOR
130142-0048	2982	YELLOW

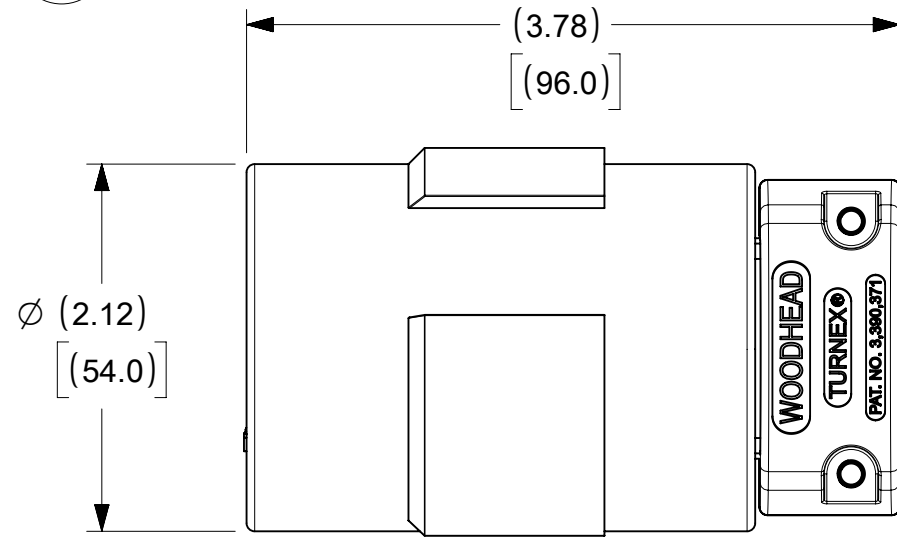

**WIRING TERMINATION**

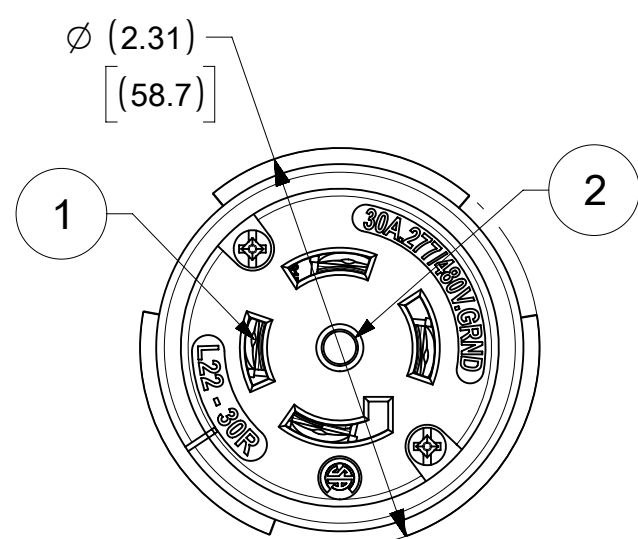
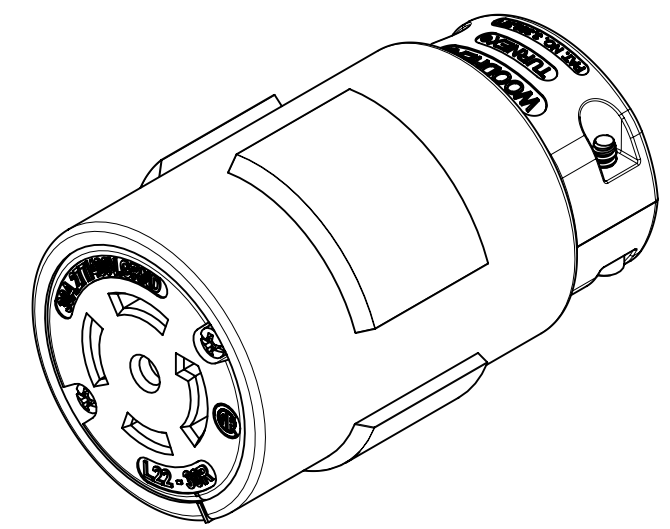
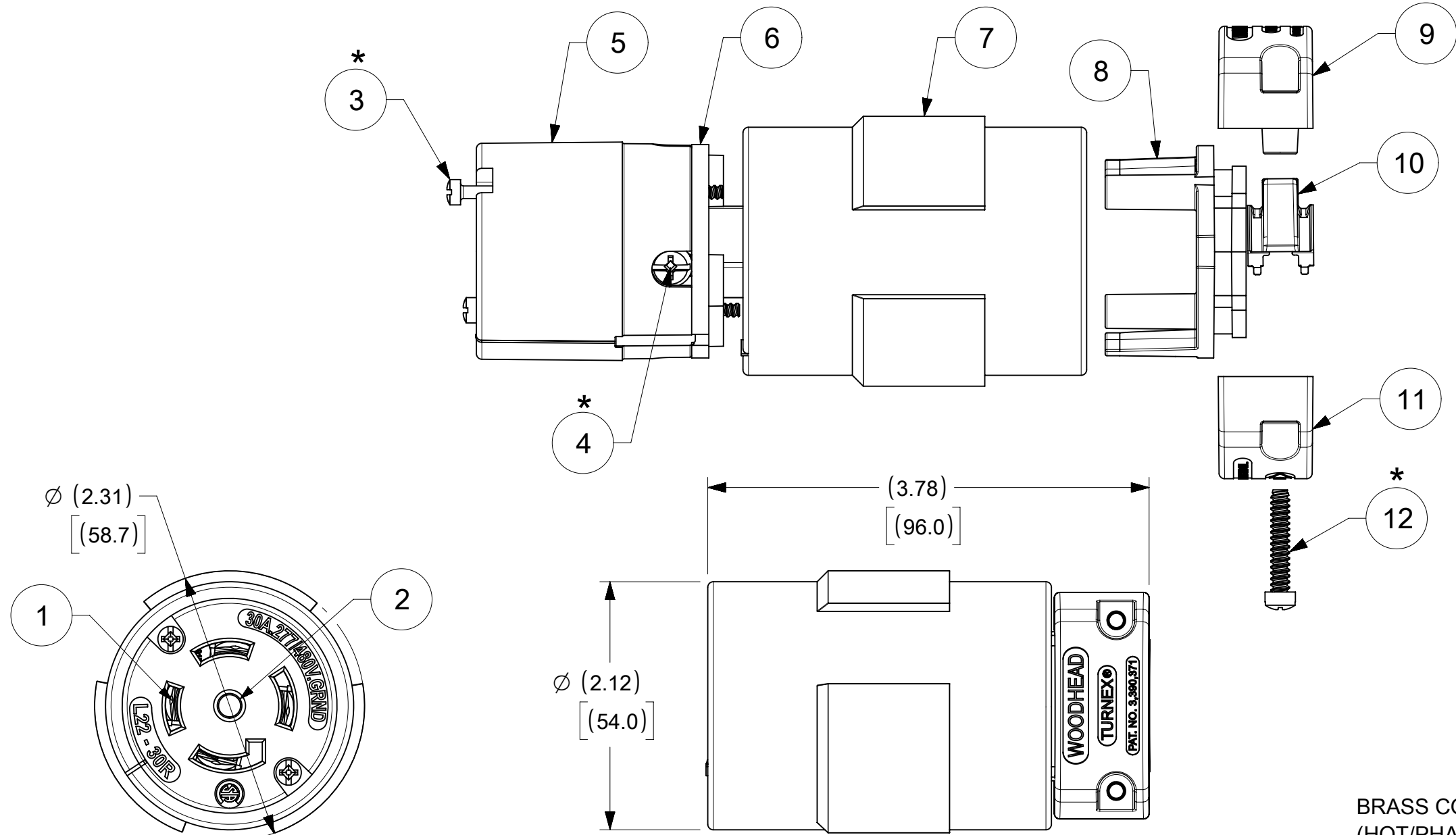
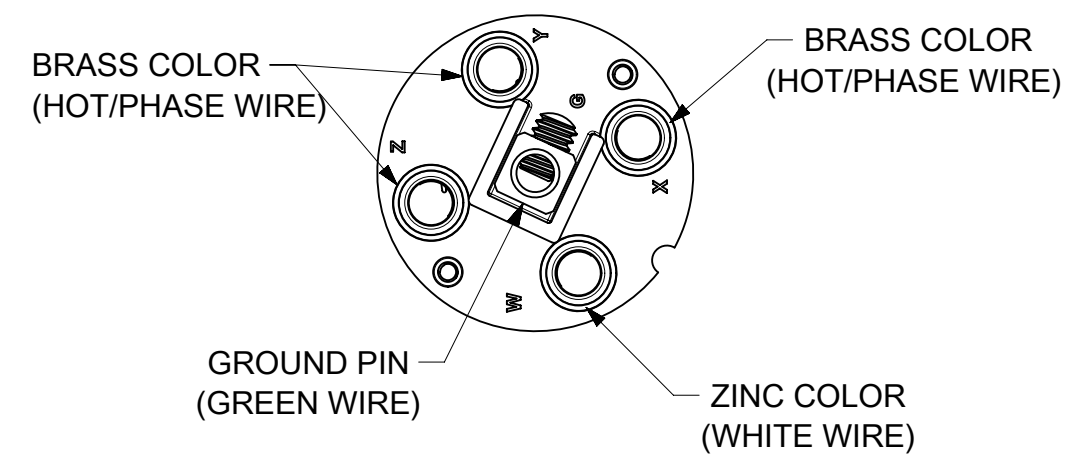

\* FOR SCREW TORQUE, SEE ASSEMBLY INSTRUCTIONS

ITEM NO.	DESCRIPTIONS	MATERIAL	QTY.
1	CLIP ASSEMBLY	BRASS, NICKEL PLATED	4
2	GROUND PIN	BRASS, NICKEL PLATED	1
3	RETAINING SCREWS	STAINLESS STEEL	2
4	TERMINAL SCREWS/CLAMP ASSEMBLY	BRASS, ZINC PLATED	4
5	INSERT	NYLON	1
6	TERMINAL COVER	POLYCARBONATE	1
7	CONNECTOR HUSK	RUBBER	1
8	CLAMP SUPPORT	NYLON	1
9	CLAMP CORD MALE	NYLON	1
10	CLAMP CORD INSERT	NYLON	1
11	CLAMP CORD FEMALE	NYLON	1
12	RETAINING SCREWS	STAINLESS STEEL	2

SYMBOLS		THIS DRAWING CONTAINS INFORMATION THAT IS PROPRIETARY TO MOLEX ELECTRONIC TECHNOLOGIES, LLC AND SHOULD NOT BE USED WITHOUT WRITTEN PERMISSION	
▽ = 0	DIMENSION UNITS	SCALE	CURRENT REV DESC: NEW RELEASE
▽ = 0	INCH/MM	NTS	
▽ = 0	GENERAL TOLERANCES (UNLESS SPECIFIED)		<p><b>molex</b></p> <p>SUPER-SAFEWAY CONN NEMA 4P5W L22-30</p> <p>PRODUCT CUSTOMER DRAWING</p> <p>DOCUMENT NUMBER: 1301420048   DOC TYPE: PSD   DOC PART: 000   REVISION: A1</p> <p>MATERIAL NUMBER: SEE TABLE   CUSTOMER: GENERAL MARKET   SHEET NUMBER: 1 OF 1</p>
▽ = 0		MM	
▽ = 0		INCH	
▽ = 0	4 PLACES	±	
▽ = 0	3 PLACES	±	
▽ = 0	2 PLACES	±	
▽ = 0	1 PLACE	±	
▽ = 0	0 PLACES	±	
▽ = 0	ANGULAR TOL	± °	
▽ = 0	DRAFT WHERE APPLICABLE MUST REMAIN WITHIN DIMENSIONS	THIRD ANGLE PROJECTION	DRAWING SERIES: B-SIZE 130142