

- NOTES:
- MATERIAL:
 'A' = NYLON V-0 LOW HALOGEN; COLOR: BLACK
 'B' = NYLON V-2 GLOW WIRE CAPABLE; COLOR: BLACK
 'C' = NYLON V-2; COLOR: BLACK
 - FINISH: NONE
 - PRODUCT SPECIFICATION: PS-172718-0000 and 2029880001-PS
 APPLICATION SPECIFICATION: AS-172718-0000
 - PACKAGING SPECIFICATION: BULK
 PK-172708-0000
 - THIS PART TO BE USED WITH FEMALE TERMINAL SERIES 172718, 202988 AND TPA SERIES 172709.
 - THIS PART MATES WITH SERIES 5559, 5566, 5569, 172762-0***, 172762-1***, 172767.
 - THIS PART CONFORMS TO CLASS 'B' REQUIREMENTS OF COSMETIC SPECIFICATION PS-45499-002.
 - THIS PRODUCT MUST BE USED WITH THE TPA INSTALLED.

THIS DRAWING CONTAINS INFORMATION THAT IS PROPRIETARY TO MOLEX ELECTRONIC TECHNOLOGIES, LLC AND SHOULD NOT BE USED WITHOUT WRITTEN PERMISSION									
DIMENSION UNITS		SCALE		CURRENT REV DESC:					
mm		NTS							
GENERAL TOLERANCES (UNLESS SPECIFIED)				EC NO: 768511				HOUSING, DUAL ROW RECEPTACLE MINI-FIT TPA2	
ANGULAR TOL ± °				DRWN: JERRYW8 2023/11/06					
4 PLACES ±				CHK'D: XQZHANG 2023/11/15				PRODUCT CUSTOMER DRAWING	
3 PLACES ±				APPR: XQZHANG 2023/11/15					
2 PLACES ± 0.13				INITIAL REVISION:				DOCUMENT NUMBER SD-172708-0000	
1 PLACE ± 0.2				DRWN: TGREGORI 2014/09/10					
0 PLACES ±				APPR: TGREGORI 2014/09/24				DOC TYPE DOC PART REVISION PSD 000 H7	
DRAFT WHERE APPLICABLE MUST REMAIN WITHIN DIMENSIONS				THIRD ANGLE PROJECTION		DRAWING		SHEET NUMBER	
						C-SIZE		172708	
MATERIAL NUMBER		CUSTOMER		SERIES		MATERIAL NUMBER		SHEET NUMBER	
SEE TABLE		GENERAL MARKET		172708		SEE TABLE		1 OF 4	

PART NUMBER	CKTS	DIM C	DIM D	MATERIAL
172708-0002	2	8.00	11.80	A
172708-0102				B
172708-0202				C
172708-0004	4	9.60	13.40	A
172708-0104				B
172708-0204				C
172708-0006	6	13.80	17.60	A
172708-0106				B
172708-0206				C
172708-0008	8	18.00	21.80	A
172708-0108				B
172708-0208				C
172708-0010	10	22.20	26.00	A
172708-0110				B
172708-0210				C
172708-0012	12	26.40	30.20	A
172708-0112				B
172708-0212				C

POLARIZATION DETAIL

SHOWN WITHOUT TPA OR TERMINAL FOR CLARITY

2 CKT

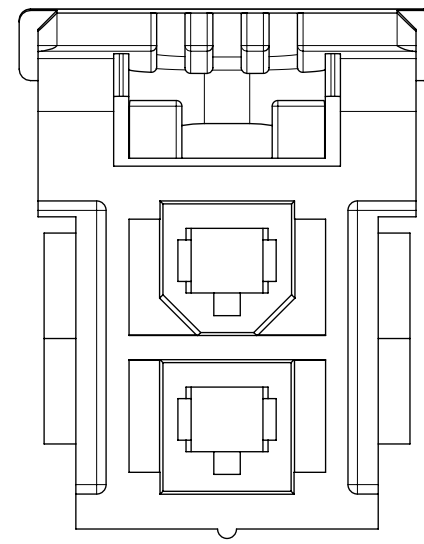

8 CKT

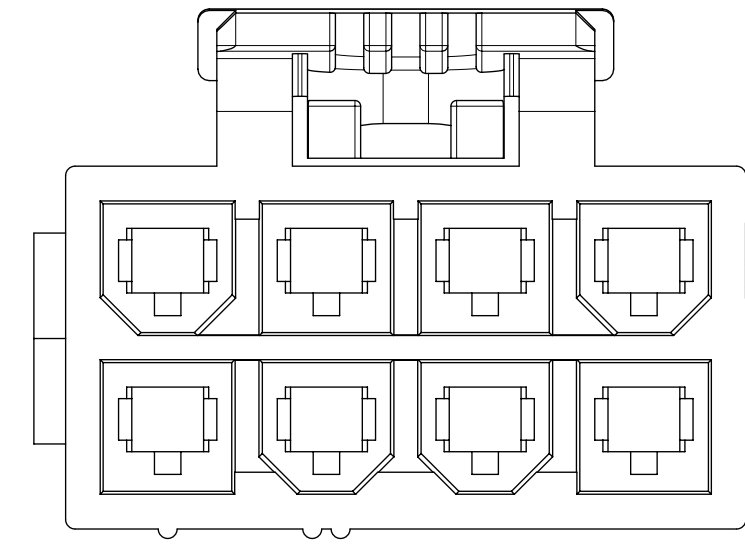

4 CKT

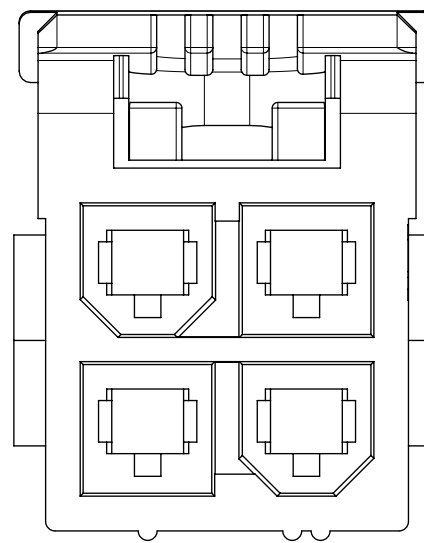

10 CKT

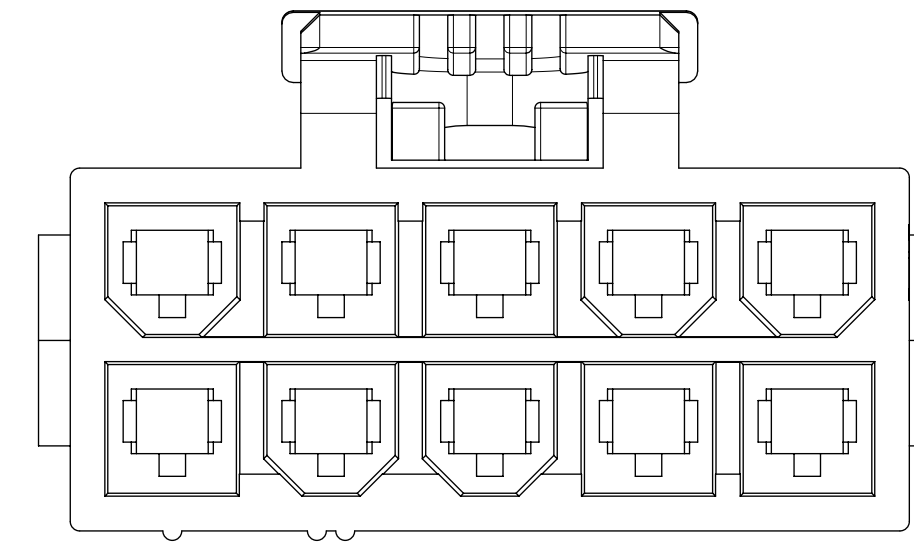

6 CKT

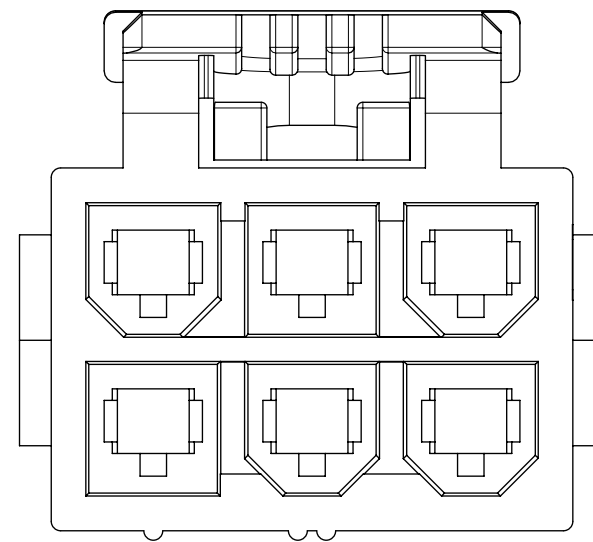

12 CKT

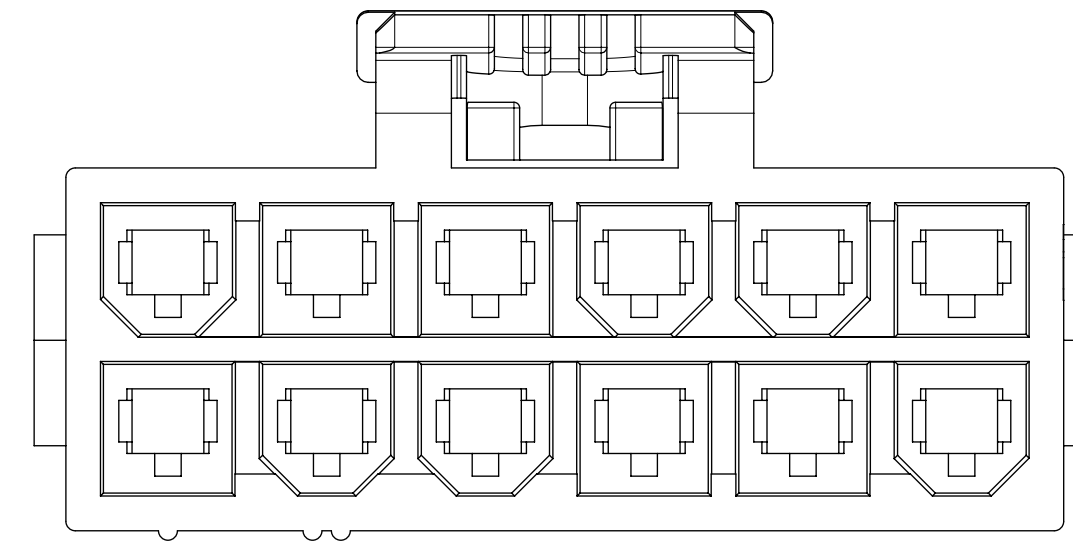

THIS DRAWING CONTAINS INFORMATION THAT IS PROPRIETARY TO MOLEX ELECTRONIC TECHNOLOGIES, LLC AND SHOULD NOT BE USED WITHOUT WRITTEN PERMISSION									
DIMENSION UNITS		SCALE		CURRENT REV DESC:				molex	
mm		NTS							
GENERAL TOLERANCES (UNLESS SPECIFIED)				EC NO: 768511				HOUSING, DUAL ROW RECEPTACLE MINI-FIT TPA2	
ANGULAR TOL ± °				DRWN: JERRYW8 2023/11/06					
4 PLACES ±				CHK'D: XQZHANG 2023/11/15				PRODUCT CUSTOMER DRAWING	
3 PLACES ±				APPR: XQZHANG 2023/11/15					
2 PLACES ± 0.13				INITIAL REVISION:				DOCUMENT NUMBER	
1 PLACE ± 0.2				DRWN: TGREGORI 2014/09/10				SD-172708-0000	
0 PLACES ±				APPR: TGREGORI 2014/09/24				DOC TYPE DOC PART REVISION	
DRAFT WHERE APPLICABLE MUST REMAIN WITHIN DIMENSIONS				THIRD ANGLE PROJECTION		DRAWING		SHEET NUMBER	
				C-SIZE		SERIES		MATERIAL NUMBER CUSTOMER	
				THIRD ANGLE PROJECTION		172708		SEE TABLE GENERAL MARKET	
								2 OF 4	

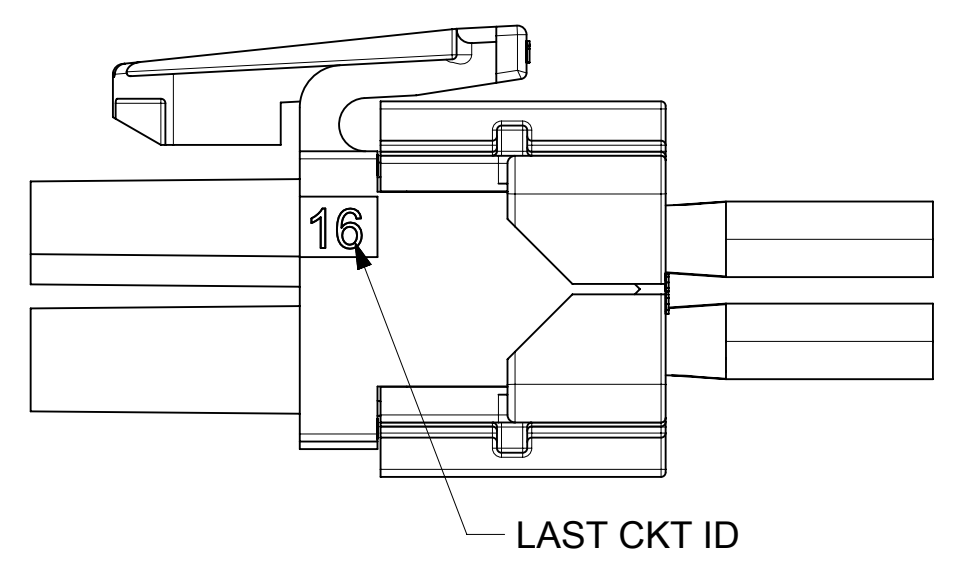
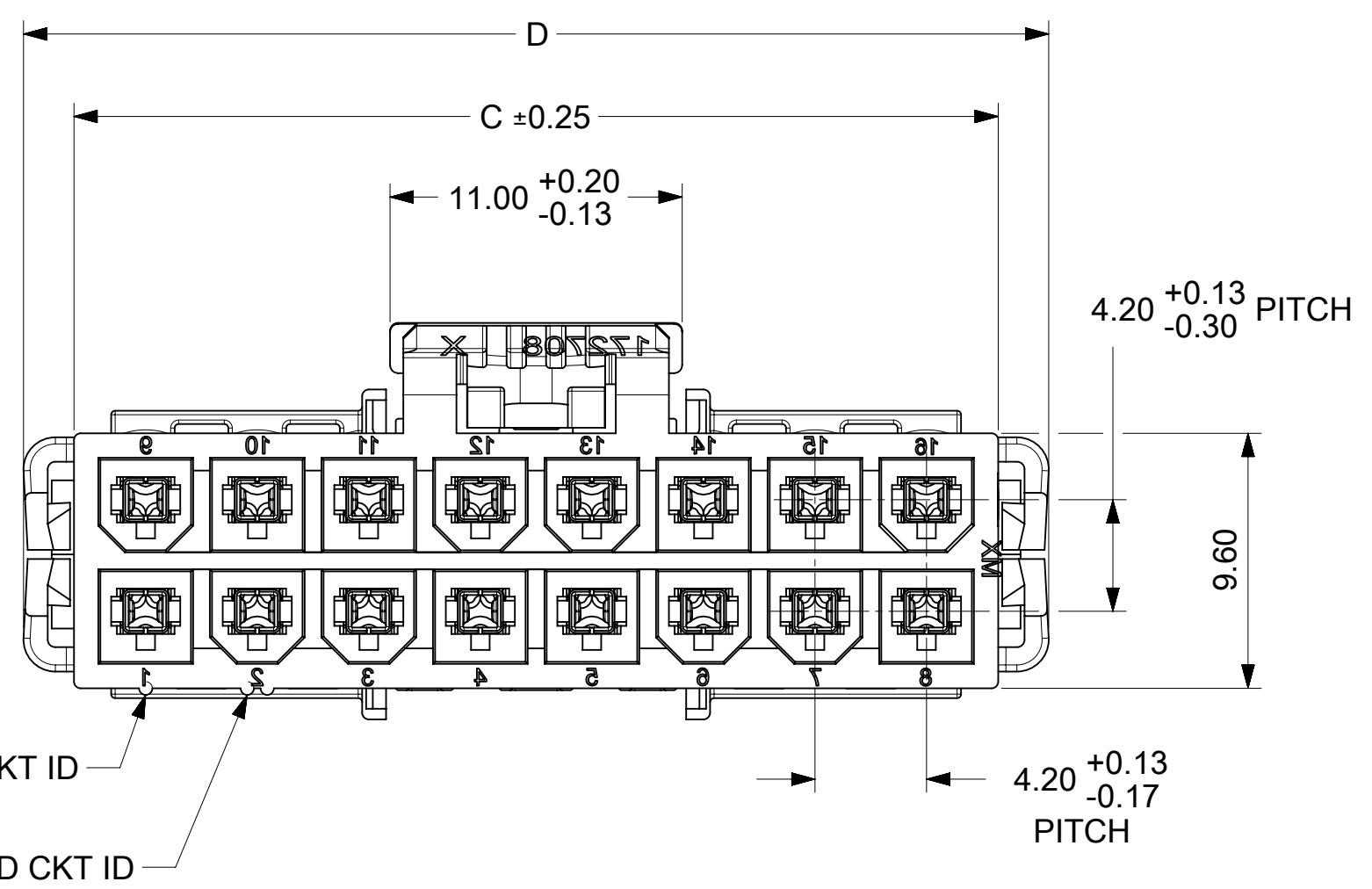
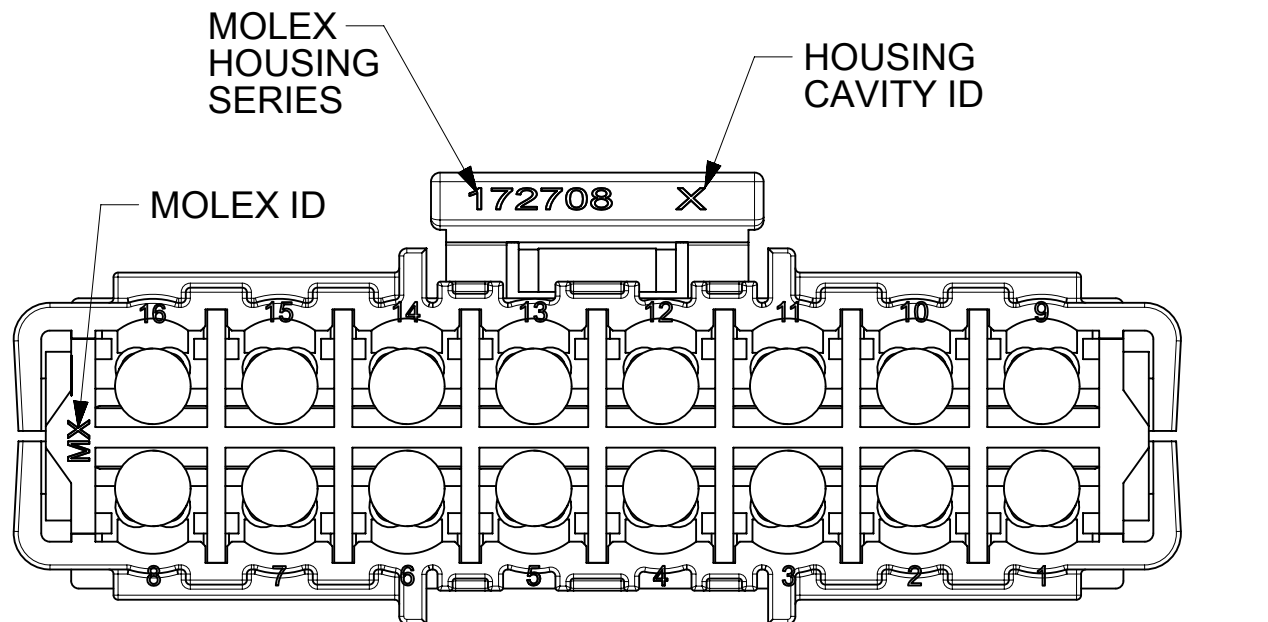
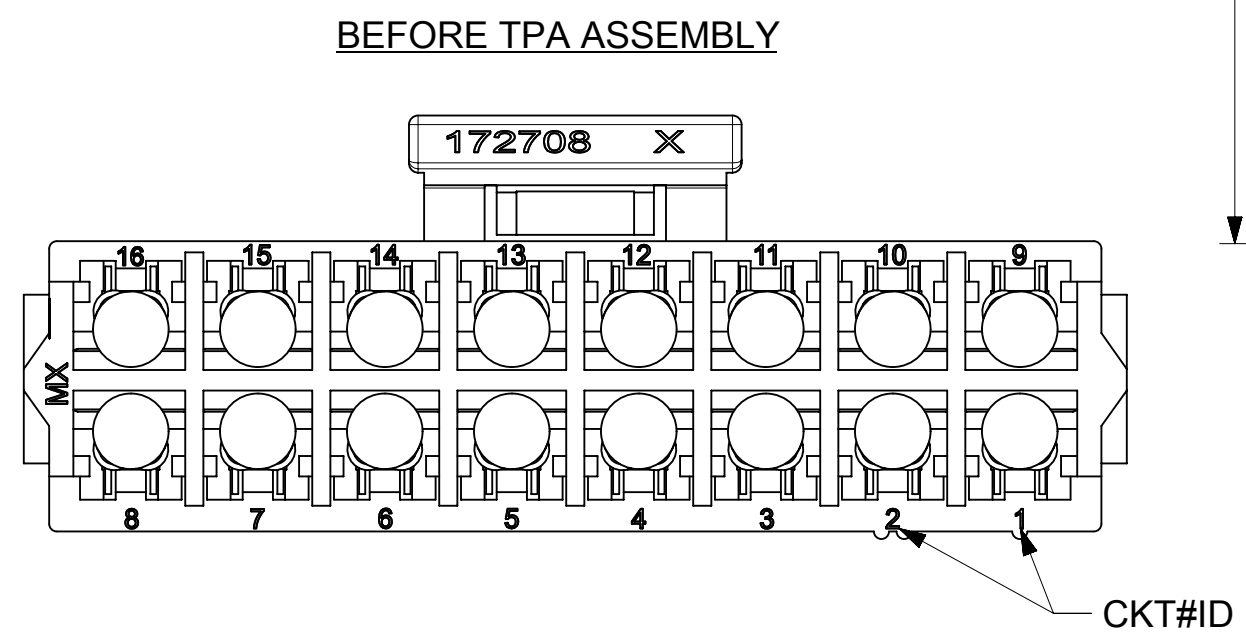
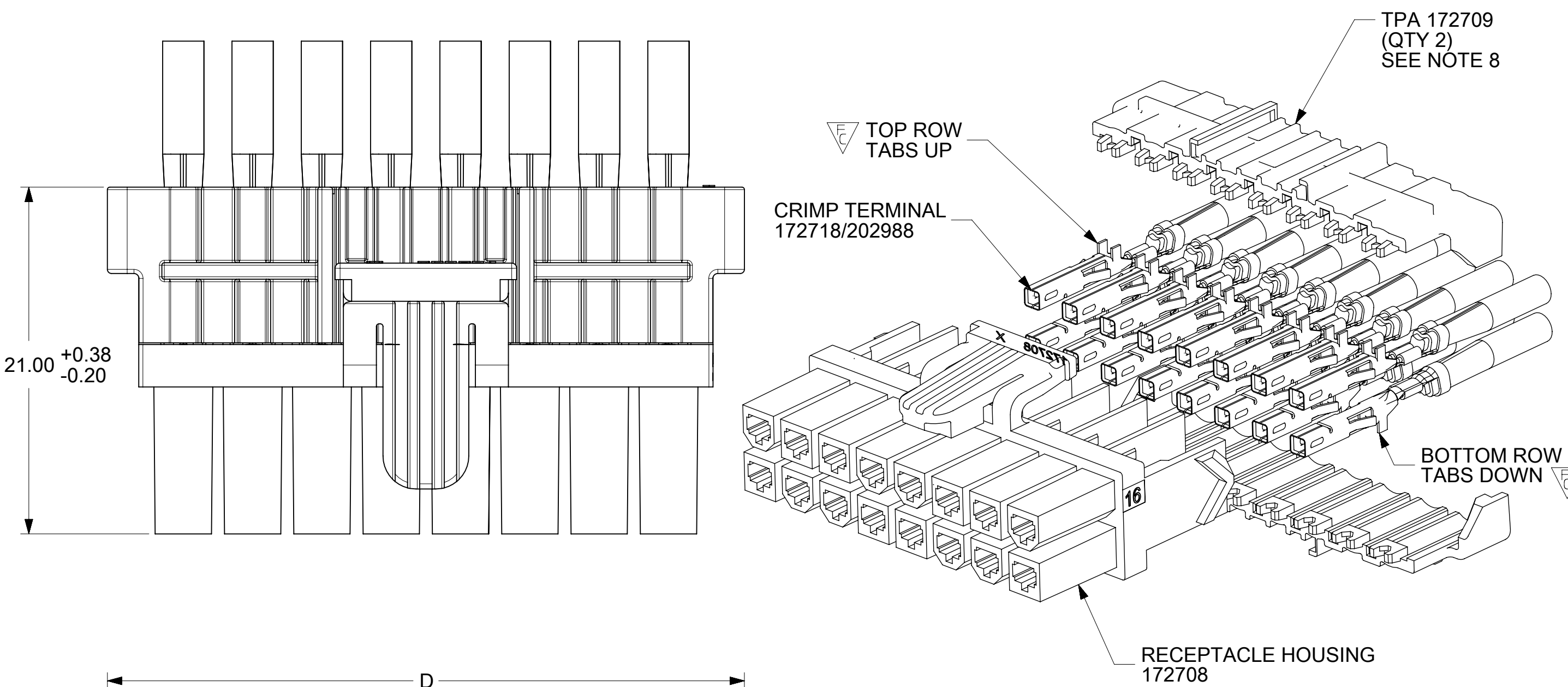

- NOTES:**
1. MATERIAL:
 'A' = NYLON V-0 LOW HALOGEN; COLOR: BLACK
 'B' = NYLON V-2 GLOW WIRE CAPABLE; COLOR: BLACK
 2. FINISH: NONE
 3. PRODUCT SPECIFICATION: PS-172718-0000 and 2029880001-PS
 APPLICATION SPECIFICATION: AS-172718-0000
 4. PACKAGING SPECIFICATION: BULK
 1727080001-PK
 REFER TO AS-45499-001 FOR MOISTURIZING NYLON CONNECTOR PARTS.
 5. THIS PART TO BE USED WITH FEMALE TERMINAL SERIES 172718, 202988 AND TPA SERIES 172709.
 6. THIS PART MATES WITH SERIES 5559, 5566, 5569 AND 172767.
 7. THIS PART CONFORMS TO CLASS 'B' REQUIREMENTS OF COSMETIC SPECIFICATION PS-45499-002.
 8. THIS PRODUCT MUST BE USED WITH THE TPA INSTALLED.

THIS DRAWING CONTAINS INFORMATION THAT IS PROPRIETARY TO MOLEX ELECTRONIC TECHNOLOGIES, LLC AND SHOULD NOT BE USED WITHOUT WRITTEN PERMISSION									
DIMENSION UNITS		SCALE		CURRENT REV DESC:					
mm		NTS							
GENERAL TOLERANCES (UNLESS SPECIFIED)									
ANGULAR TOL ± °									
4 PLACES ±				EC NO: 768511					
3 PLACES ±				DRWN: JERRYW8		2023/11/06			
2 PLACES ± 0.13				CHK'D: XQZHANG		2023/11/15			
1 PLACE ± 0.2				APPR: XQZHANG		2023/11/15			
0 PLACES ±				INITIAL REVISION:					
DRAFT WHERE APPLICABLE MUST REMAIN WITHIN DIMENSIONS		THIRD ANGLE PROJECTION		DRWN: TGREGORI		2014/09/10			
				APPR: TGREGORI		2014/09/24			
				DRAWING		SERIES			
				C-SIZE		172708			
DOCUMENT STATUS		P1		RELEASE DATE		2023/11/15 09:48:29			
DOCUMENT NUMBER		CUSTOMER		MATERIAL NUMBER		SHEET NUMBER			
SD-172708-0000		GENERAL MARKET		SEE TABLE		3 OF 4			

PART NUMBER	CKTS	DIM C	DIM D	MATERIAL
1727080014	14	30.60	34.40	A
1727080114				B
1727080016	16	34.80	38.60	A
1727080116				B
1727080018	18	39.00	42.80	A
1727080118				B
1727080020	20	43.20	47.00	A
1727080120				B
1727080022	22	47.40	51.20	A
1727080122				B
1727080024	24	51.60	55.40	A
1727080124				B

POLARIZATION DETAIL

SHOWN WITHOUT TPA OR TERMINAL FOR CLARITY

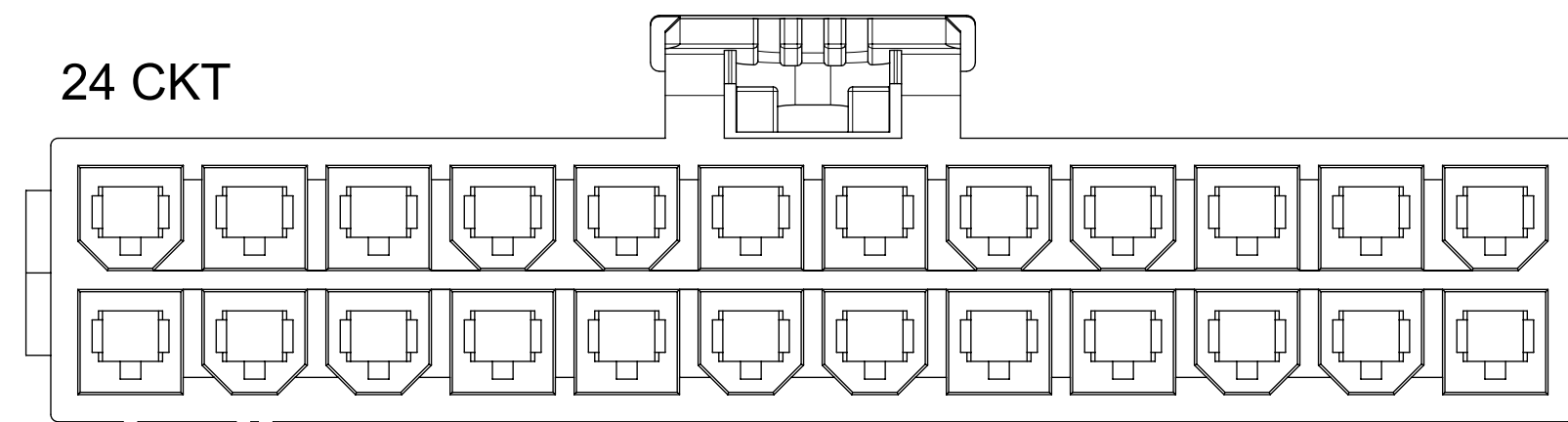
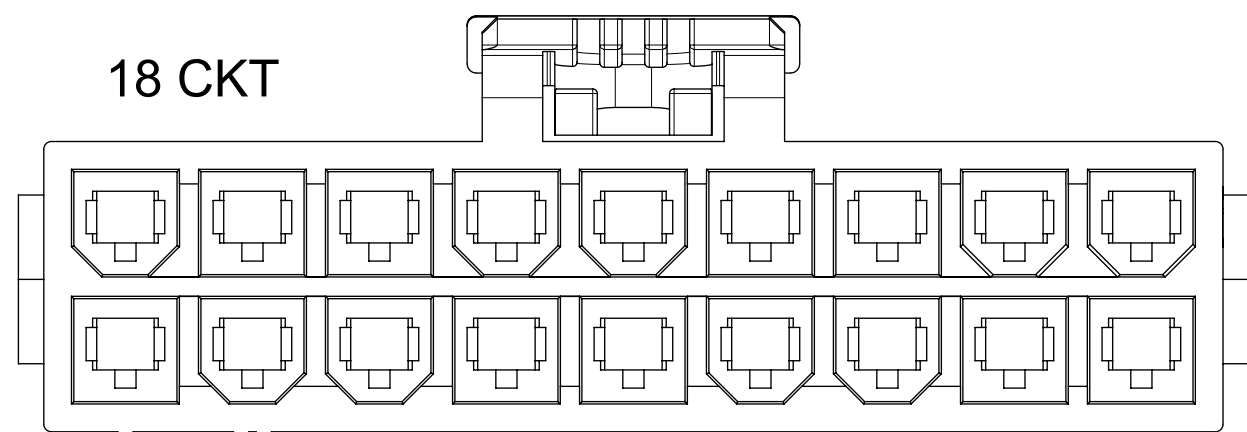
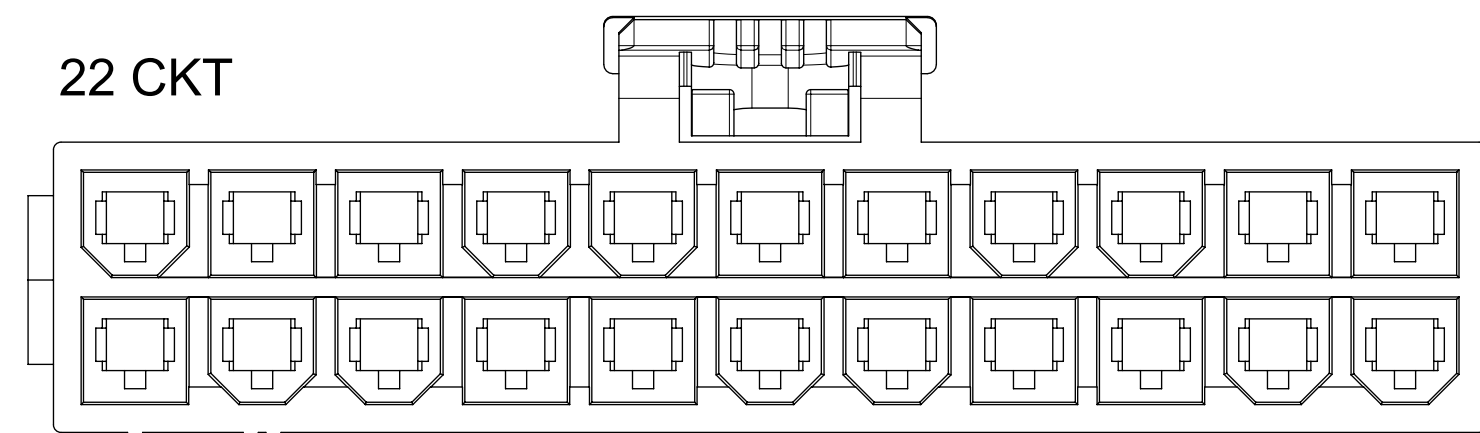
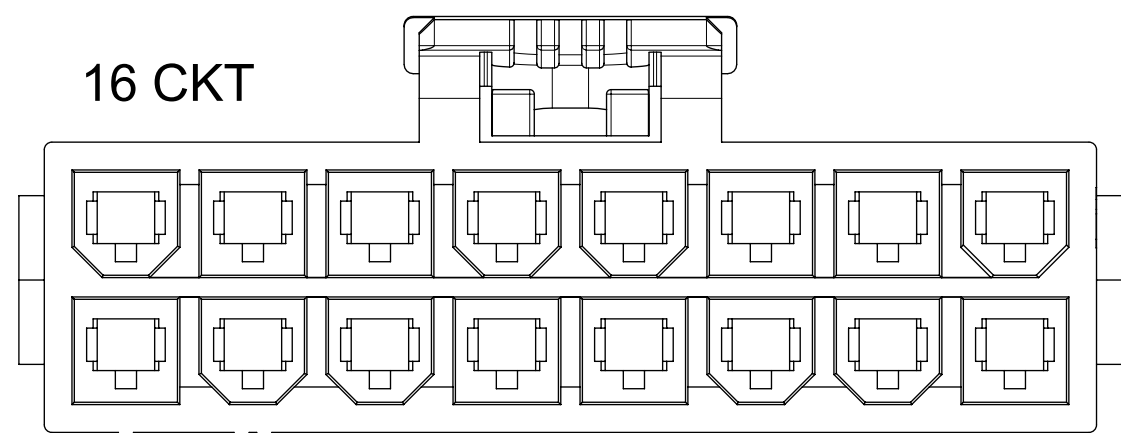
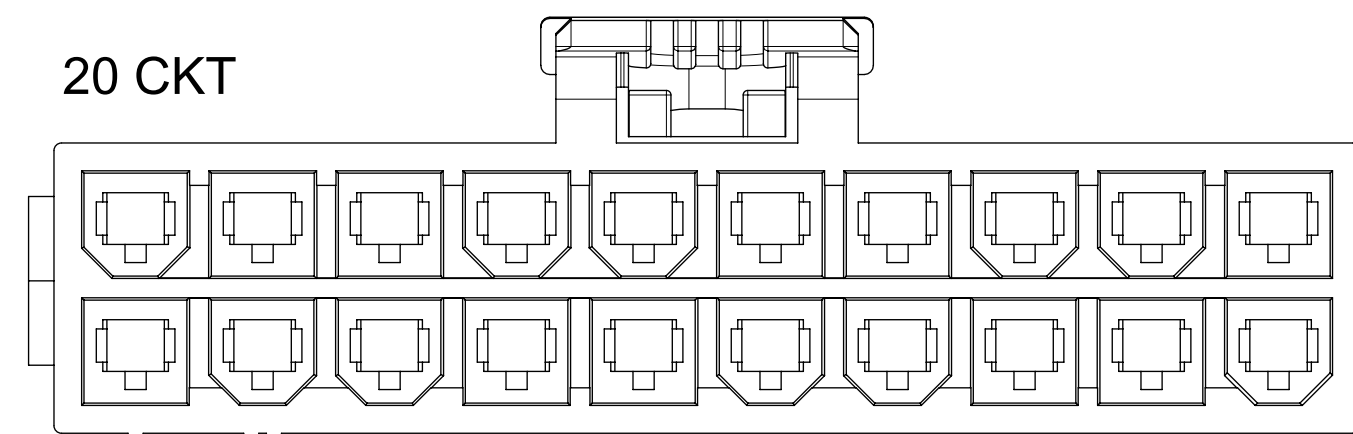
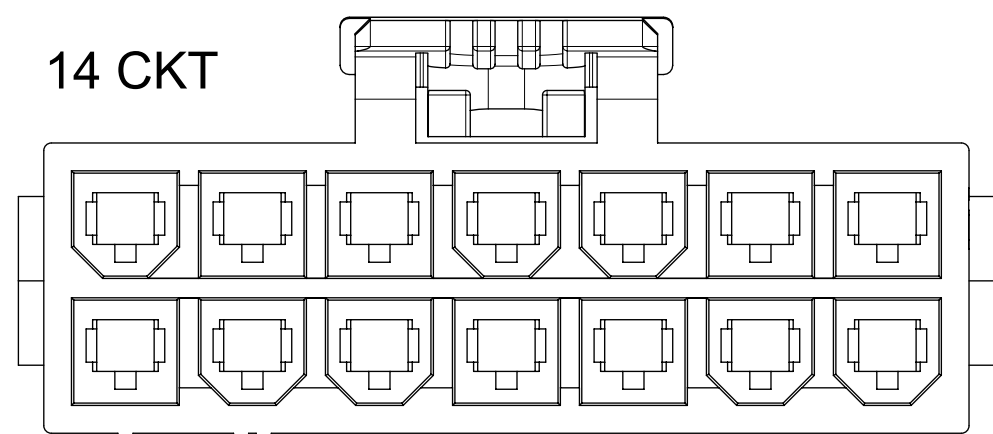

THIS DRAWING CONTAINS INFORMATION THAT IS PROPRIETARY TO MOLEX ELECTRONIC TECHNOLOGIES, LLC AND SHOULD NOT BE USED WITHOUT WRITTEN PERMISSION									
DIMENSION UNITS		SCALE		CURRENT REV DESC:				molex	
mm		NTS							
GENERAL TOLERANCES (UNLESS SPECIFIED)				EC NO: 768511				HOUSING, DUAL ROW RECEPTACLE MINI-FIT TPA2	
ANGULAR TOL ± °				DRWN: JERRYW8 2023/11/06					
4 PLACES ±				CHK'D: XQZHANG 2023/11/15				PRODUCT CUSTOMER DRAWING	
3 PLACES ±				APPR: XQZHANG 2023/11/15					
2 PLACES ± 0.13				INITIAL REVISION:				DOCUMENT NUMBER	
1 PLACE ± 0.2				DRWN: TGREGORI 2014/09/10				SD-172708-0000	
0 PLACES ±				APPR: TGREGORI 2014/09/24				DOC TYPE DOC PART REVISION	
DRAFT WHERE APPLICABLE MUST REMAIN WITHIN DIMENSIONS				THIRD ANGLE PROJECTION		DRAWING		SERIES	
				C-SIZE		172708		MATERIAL NUMBER CUSTOMER SHEET NUMBER	
						SEE TABLE GENERAL MARKET		4 OF 4	

DOCUMENT STATUS	P1	RELEASE DATE	2023/11/15 09:48:29
-----------------	----	--------------	---------------------