

ORDER NO.	WOODHEAD NO.	COLOR
130147-0107	29W75MB	YELLOW

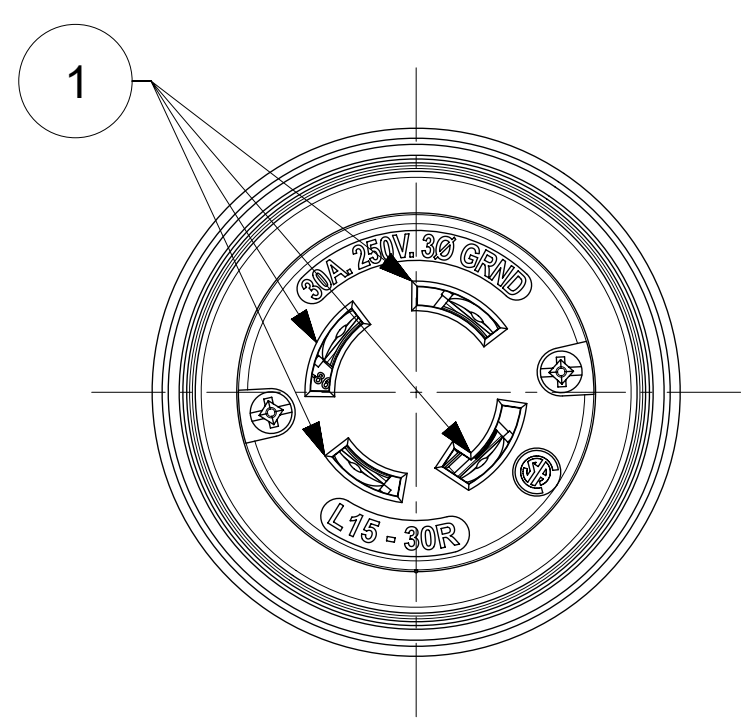

FACE VIEW

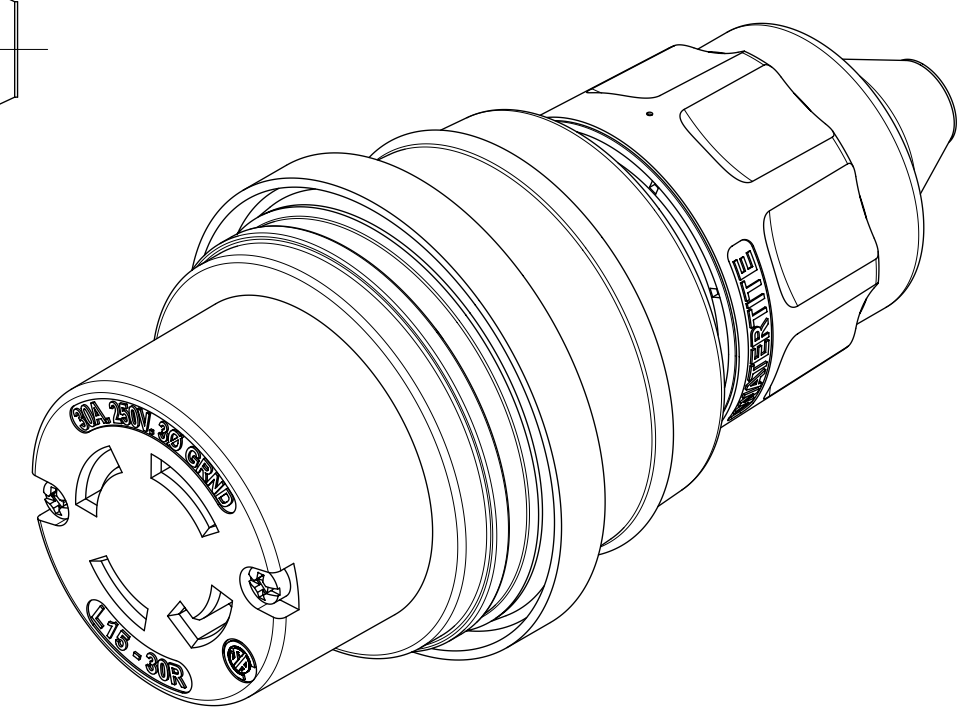
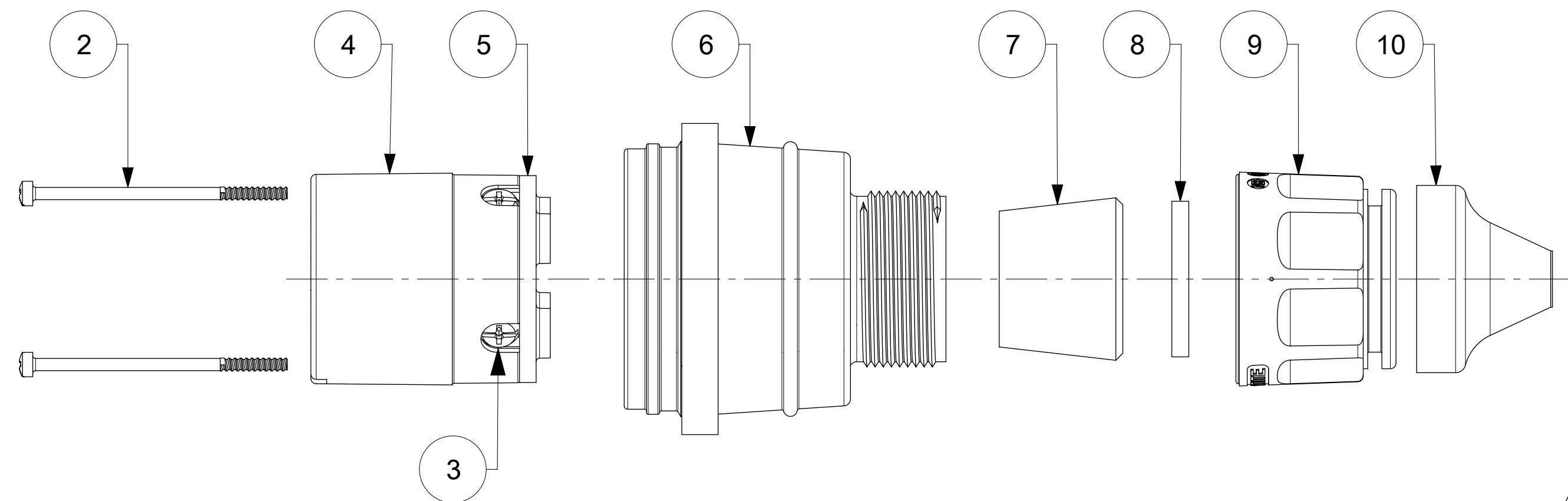
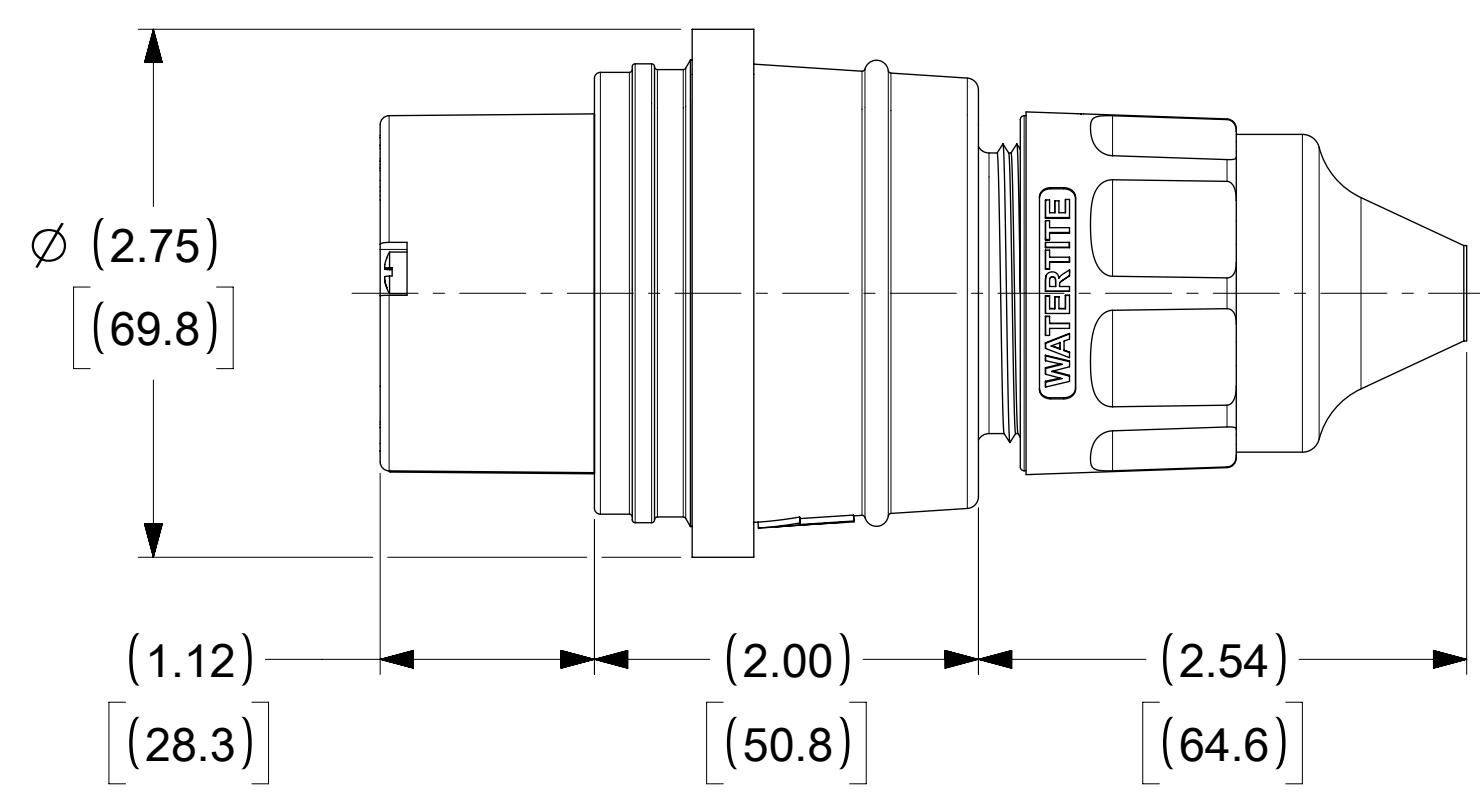

ITEM NO.	DESCRIPTIONS	MATERIAL	QTY.
1	BLADE	BRASS, NICKEL PLATED	4
2	RETAINING SCREWS	STAINLESS STEEL	2
3	CLAMP AND TERMINAL SCREW ASSY	BRASS, ZINC PLATED	4
4	INSERT	NYLON	1
5	TERMINAL COVER	POLYCARBONATE	1
6	HOUSING	SILICONE WITH NYLON THREAD	1
7	GROMMET	RUBBER	4
8	FRICTION RING	NYLON	1
9	COMPRESSION NUT	NYLON	1
10	CABLE GLOVE	SILICONE	1

NOTE:
1. "ACCEPT CABLE RANGE FROM .562" TO 1.00"

SYMBOLS DIMENSION UNITS: INCH[MM] SCALE: NTS GENERAL TOLERANCES (UNLESS SPECIFIED): 4 PLACES ± 3 PLACES ± 2 PLACES ± 1 PLACE ± 0 PLACES ± ANGULAR TOL ± ° DRAFT WHERE APPLICABLE MUST REMAIN WITHIN DIMENSIONS THIRD ANGLE PROJECTION	THIS DRAWING CONTAINS INFORMATION THAT IS PROPRIETARY TO MOLEX ELECTRONIC TECHNOLOGIES, LLC AND SHOULD NOT BE USED WITHOUT WRITTEN PERMISSION		CURRENT REV DESC: EC NO: 617635 DRWN: SRPATIL 2019/02/18 CHK'D: DNGUYEN62 2019/05/21 APPR: HKNEELAND 2019/10/16		
	PRODUCT CUSTOMER DRAWING DOCUMENT NUMBER: 1301470107 DOC TYPE: PSD DOC PART: 000 REVISION: A		INITIAL REVISION: DRWN: SRPATIL 2019/02/18 APPR: HKNEELAND 2019/10/16		