

ORDER NO.	WOODHEAD NO.	COLOR
130142-0038	2876	YELLOW

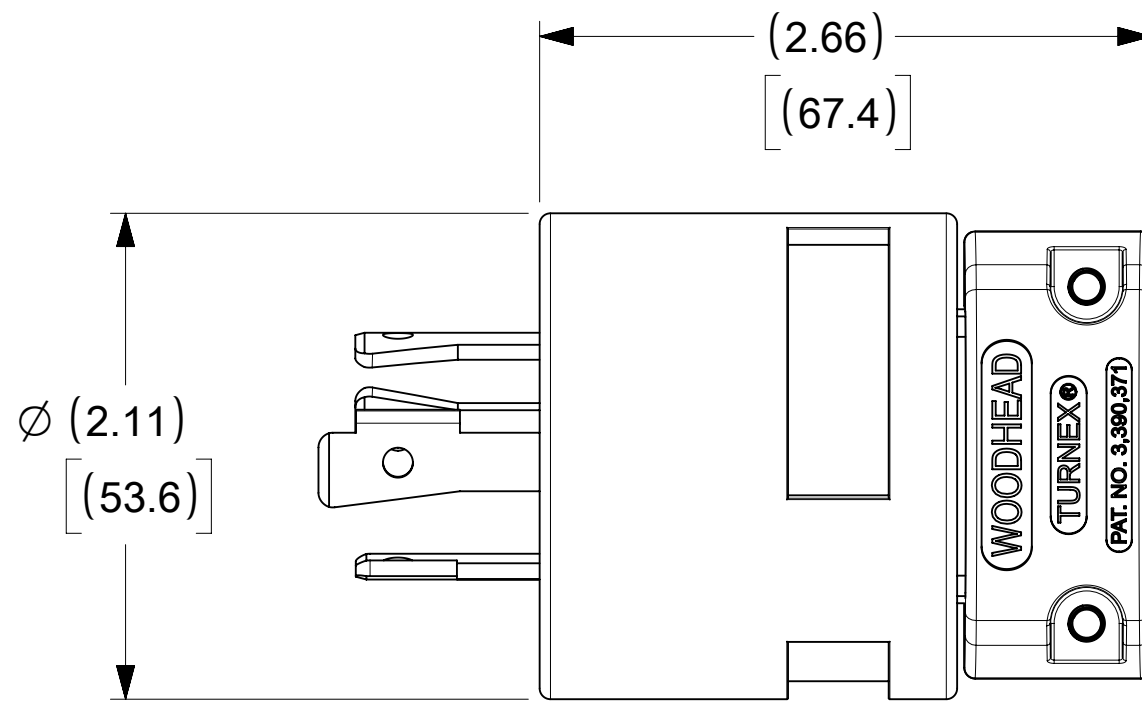

WIRING TERMINATION

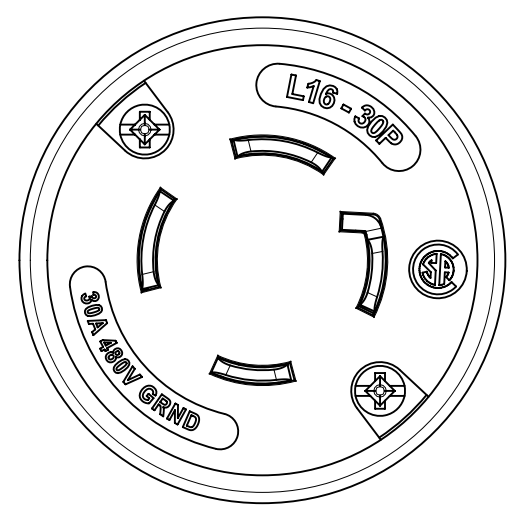
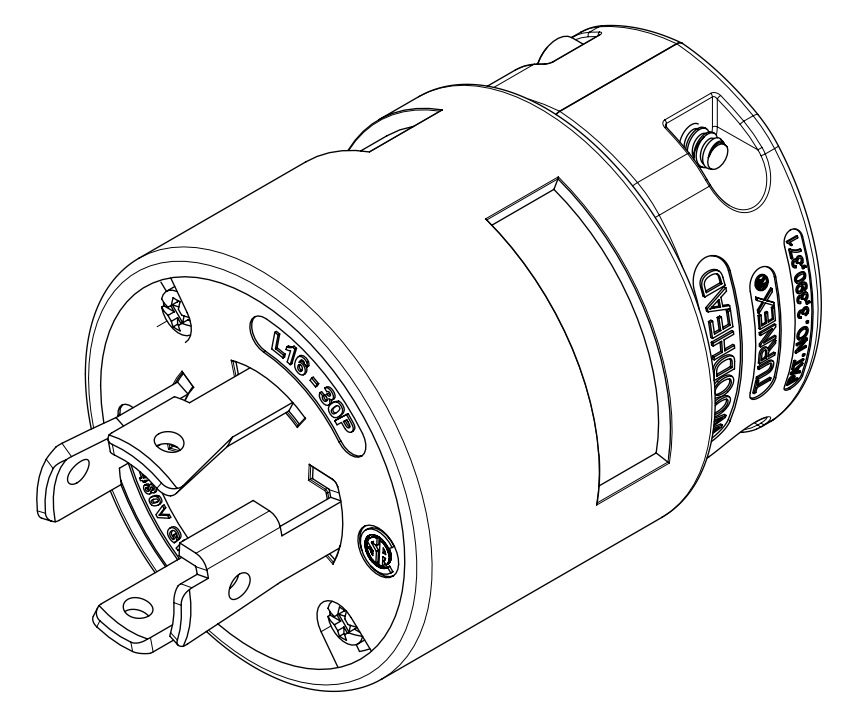
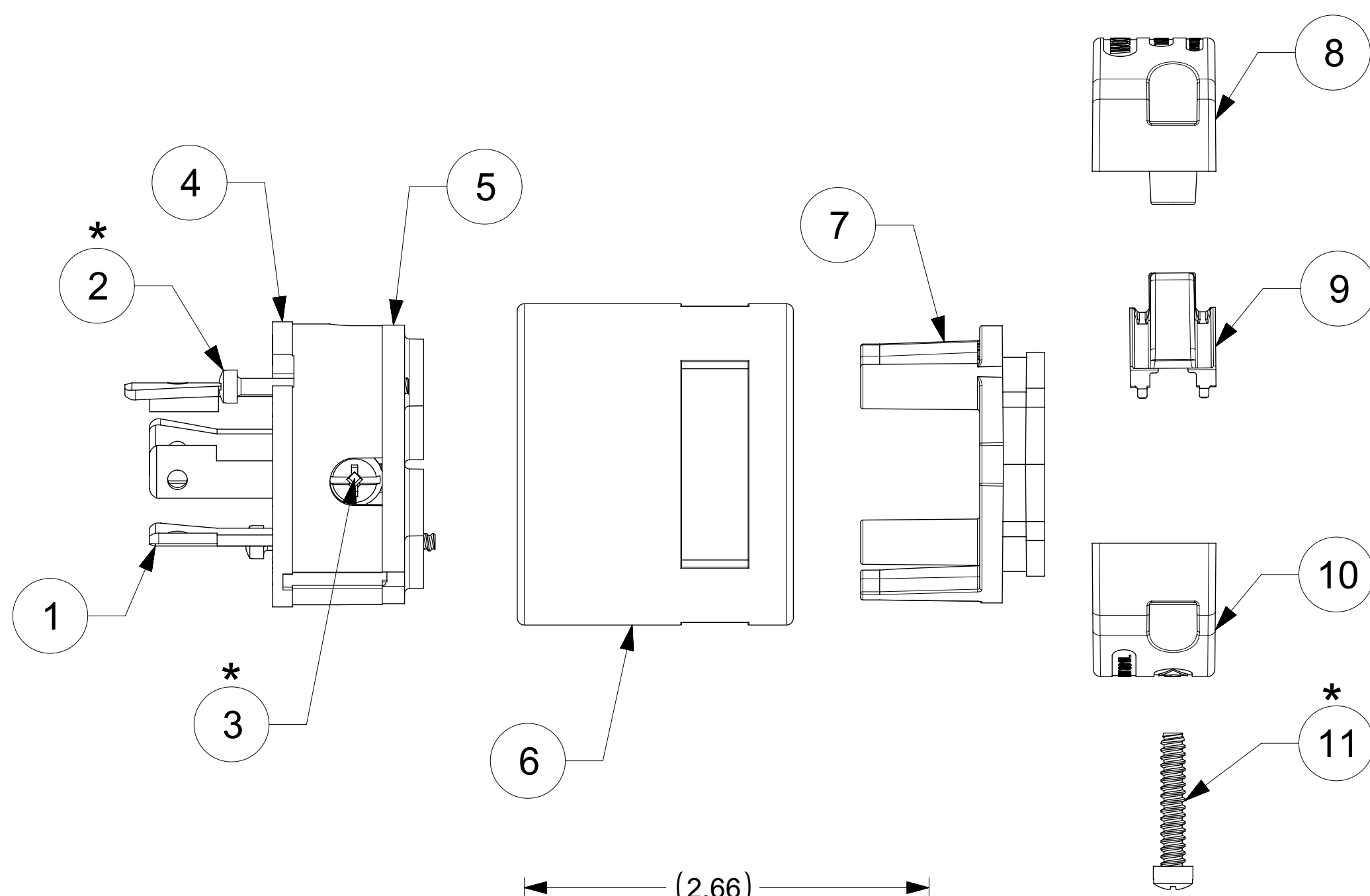
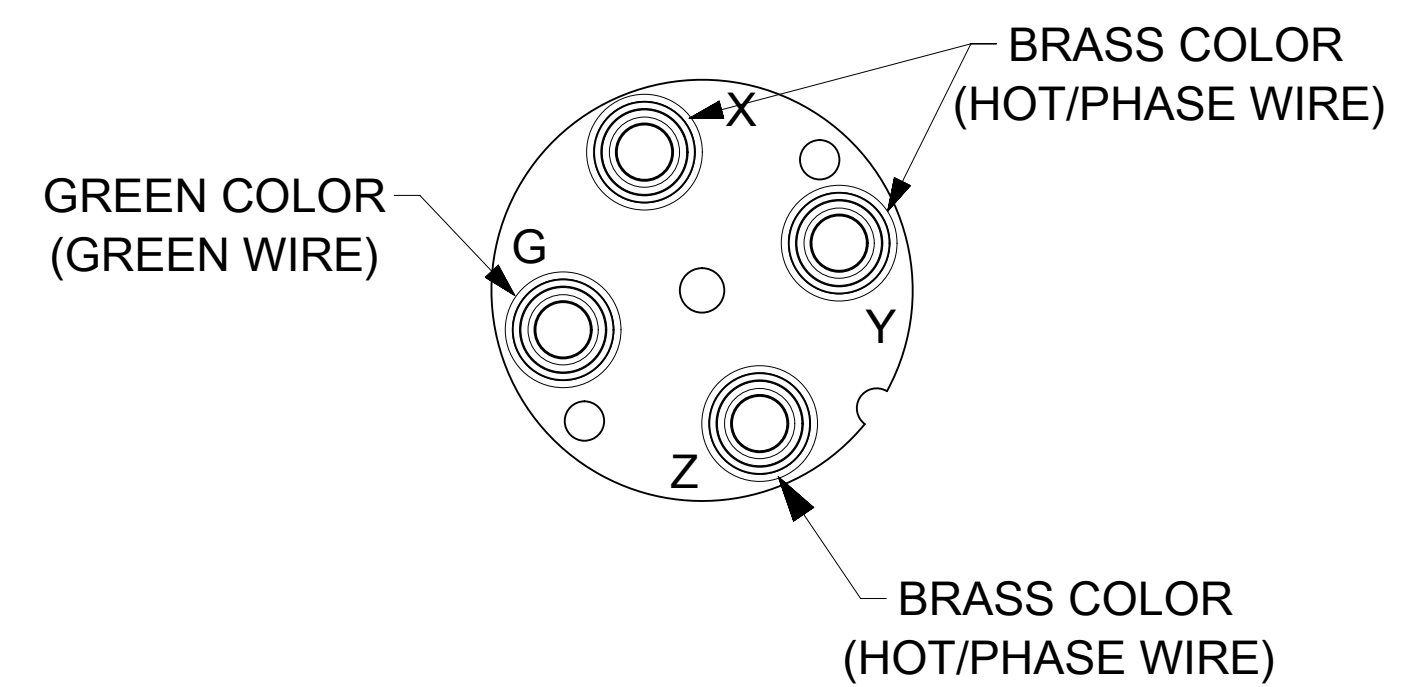

* FOR SCREW TORQUE, SEE ASSEMBLY INSTRUCTIONS

ITEM NO.	DESCRIPTION	MATERIAL	QTY.
1	BLADES	BRASS, NICKEL PLATED	4
2	RETAINING SCREWS	STAINLESS STEEL	2
3	TERMINAL SCREWS/CLAMP ASSEMBLY	BRASS, ZINC PLATED	4
4	INSERT; YELLOW	NYLON	1
5	TERMINAL COVER	POLYCARBONATE	1
6	MALE RUBBER HUSK	NYLON	1
7	CLAMP SUPPORT, YELLOW	NYLON	1
8	CLAMP CHORD MALE, YELLOW	NYLON	1
9	CLAMP CHORD INSERT, WHITE	NYLON	1
10	CLAMP CORD FEMALE, YELLOW	NYLON	1
11	RETAINING SCREWS	STAINLESS STEEL	2

SYMBOLS		THIS DRAWING CONTAINS INFORMATION THAT IS PROPRIETARY TO MOLEX ELECTRONIC TECHNOLOGIES, LLC AND SHOULD NOT BE USED WITHOUT WRITTEN PERMISSION	
▽ = 0	DIMENSION UNITS	SCALE	CURRENT REV DESC: NEW RELEASE
▽ = 0	INCH/MM	NTS	
▽ = 0	GENERAL TOLERANCES (UNLESS SPECIFIED)		
▽ = 0		MM	INCH
▽ = 0	4 PLACES	±	±
▽ = 0	3 PLACES	±	±
▽ = 0	2 PLACES	±	±
▽ = 0	1 PLACE	±	±
▽ = 0	0 PLACES	±	±
▽ = 0	ANGULAR TOL	± °	
▽ = 0	DRAFT WHERE APPLICABLE MUST REMAIN WITHIN DIMENSIONS		THIRD ANGLE PROJECTION
▽ = 0		DRAWING	SERIES
		C-SIZE	130142
			EC NO: 628448
			DRWN: ABENJAMINLW 2019/04/02
			CHK'D: DNGUYEN62 2020/02/14
			APPR: HKNEELAND 2020/06/02
			INITIAL REVISION:
			DRWN: ABENJAMINLW 2019/04/02
			APPR: HKNEELAND 2020/06/02
			PRODUCT CUSTOMER DRAWING
			DOCUMENT NUMBER
			1301420038
			DOC TYPE DOC PART REVISION
			PSD 000 A
			MATERIAL NUMBER
			SEE TABLE
			CUSTOMER
			GENERAL MARKET
			SHEET NUMBER
			1 OF 1