

KEY 1
PART NO. 2005010271

SEE NOTE 3g

PART NUMBER TUBE PACKAGING 2005058100	PART NUMBER TRAY PACKAGING 2005053013-PK	KEY	COLOR	TERMINAL QUANTITIES	
				0.5mm	1.2mm
2005010271	2005011271	1	BLACK	19	8
2005010272	2005011272	2	GREEN		
2005010273	2005011273	3	BLUE		
2005010274	2005011274	4	PURPLE		

FOUR (4) KEYS AVAILABLE
SEE INTERFACE DRAWING
SD-160029-002 FOR DEFINITION

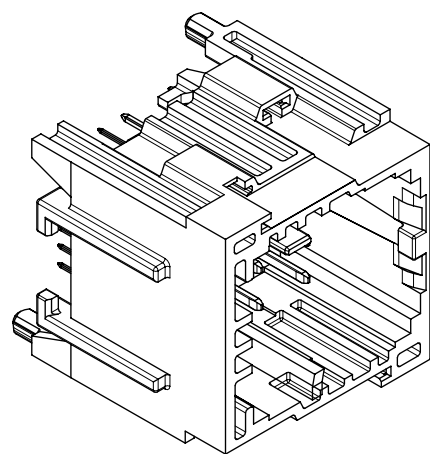

INSPECTION BALLOON NUMBER LOG
PER DRAWING REVISION: D1
LAST BALLOON NUMBER: 11B
ADDED BALLOON NUMBER: NONE
DELETED BALLOON NUMBER: NONE

NOTES: VALID UNLESS OTHERWISE SPECIFIED

1. GENERAL:
 - a. APPLICATION SPECIFICATION 2005060000-AS
 - b. PRODUCT SPECIFICATION 2005060001-PS
CLASSIFICATIONS T1V1S1 TO GMW 3191 2012
DEGREE OF PROTECTION IP40 TO ISO 20653 WITH MOLEX MATING CONNECTOR
 - c. PACKAGING SPECIFICATION PER MOLEX DRAWING
2. DESIGN - MATERIALS:
 - a. HOUSING: SPS 30% GF
 - b. BLADE TERMINALS:
 1. 0.5MM BLADES
BASE MATERIAL: COPPER ALLOY
CONDUCTIVITY ≥ 28% IACS @ 20°C
UNDERPLATE: OVERALL NICKEL
OVERPLATE: OVERALL TIN
 2. 1.2MM BLADES
BASE MATERIAL: COPPER ALLOY
CONDUCTIVITY ≥ 28% IACS @ 20°C
UNDERPLATE: OVERALL NICKEL
OVERPLATE: OVERALL TIN
3. DESIGN - GEOMETRY:
 - a. ALL GRAPHIC DATA IS BASIC (NO TOLERANCE) AND MUST BE TAKEN FROM THE DATA FILE AT ITS LATEST REVISION.
 - b. PRODUCT DESIGN MODEL NUMBER 2005010270
 - c. GEOMETRIC DIMENSIONS AND TOLERANCES PER ASME Y14.5-2009
 - d. EDGES AND UNDIMENSIONED DETAILS PER ISO13715
 - e. CORNERS SHOWN AS SHARP TO BE R 0.4 MAX.
 - f. LETTERING SHALL BE MAX POSSIBLE FOR READABILITY.
THIS INCLUDES RECYCLING CODE, CAVITY ID, VENDOR IDENTIFICATION, AND CUSTOMER MATERIAL NUMBER.
 - g. FOR BAY/POCKET DEFINITION SEE MOLEX INTERFACE DRAWING SD-160029-002
 - h. MATING HARNESS CONNECTORS MOLEX PN:
1600290011 (KEY 1)
1600290012 (KEY 2)
1600290013 (KEY 3)
1600290014 (KEY 4)
4. DESIGN - MANUFACTURING:
 - a. VISUAL DEFECTS SHALL MEET COSMETIC STANDARD PS-45499-002 (CLASS B)
 - b. REFLOW SOLDERABILITY PER SMES-152

FUNCTIONAL SYMBOLS										THIS DRAWING CONTAINS INFORMATION THAT IS PROPRIETARY TO MOLEX ELECTRONIC TECHNOLOGIES, LLC AND SHOULD NOT BE USED WITHOUT WRITTEN PERMISSION															
DIMENSION UNITS		SCALE		CURRENT REV DESC: SEE REVISION TABLE										 STAK50H MOD HDR 27 VERT SOLDER											
MM		2:1		GENERAL TOLERANCES (UNLESS SPECIFIED)																					
ANGULAR TOL		±		4 PLACES ±																					
DIVISIONAL SYMBOLS		3 PLACES ±		2 PLACES ± 0.130																					
1 PLACE ± 0.25		0 PLACES ±		DRAFT WHERE APPLICABLE MUST REMAIN WITHIN DIMENSIONS										THIRD ANGLE PROJECTION		DRAWING		SERIES		MATERIAL NUMBER		CUSTOMER		SHEET NUMBER	
STATUS: Production		DRWN: Praveen Kumar S		2024-01-09		2024-01-12		2024-01-12		2024-01-12		200501		SEE TABLE		SEE TABLE		1 OF 2							

RECOMMENDED MODULE OPENING
TO PASS ISO 20653 IP40

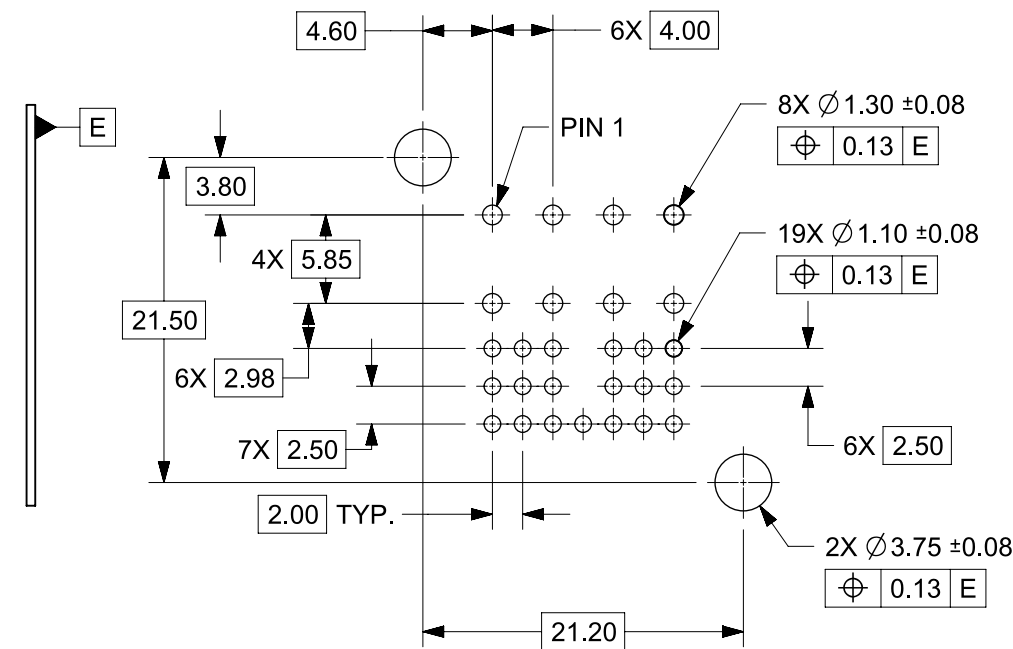
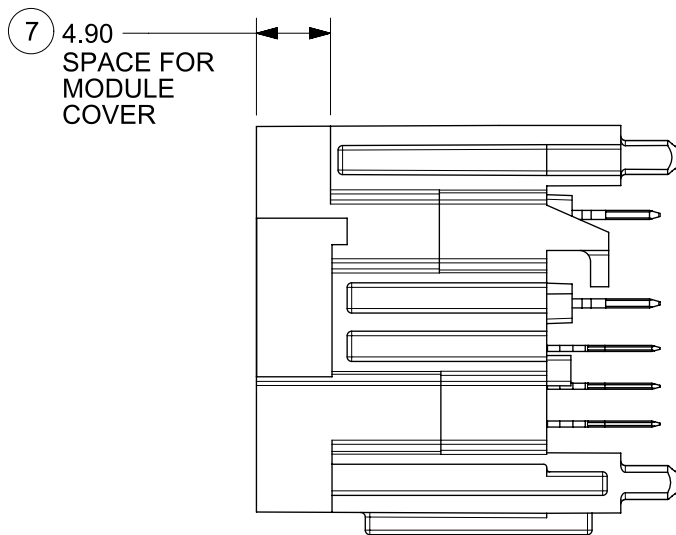
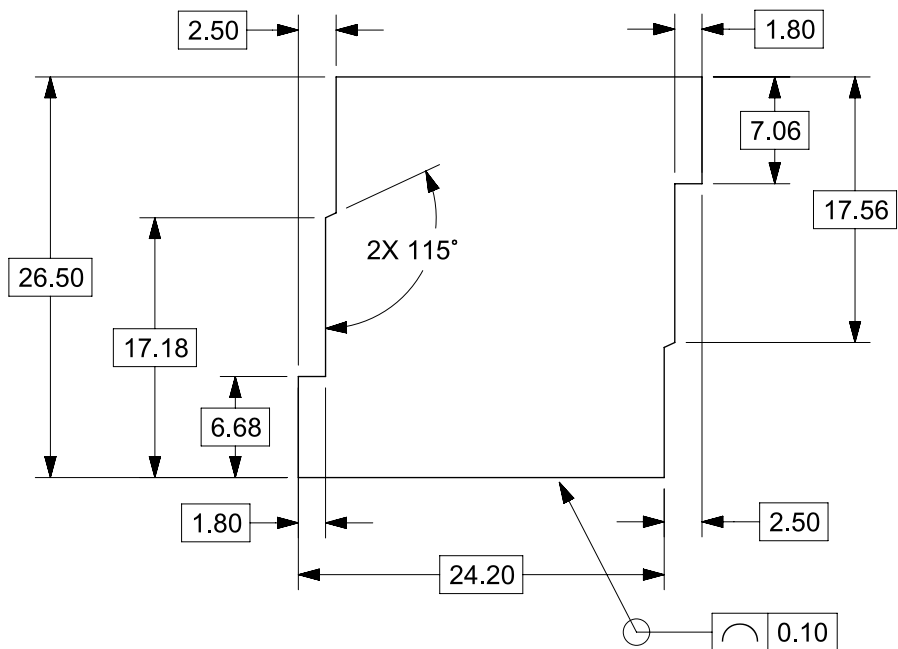

PCB LAYOUT
FOR REFERENCE

FOR SINGLE-BAY HEADER ONLY
FOR MULTIPLE-BAY STACKED HEADER SEE DRAWING 2005050000

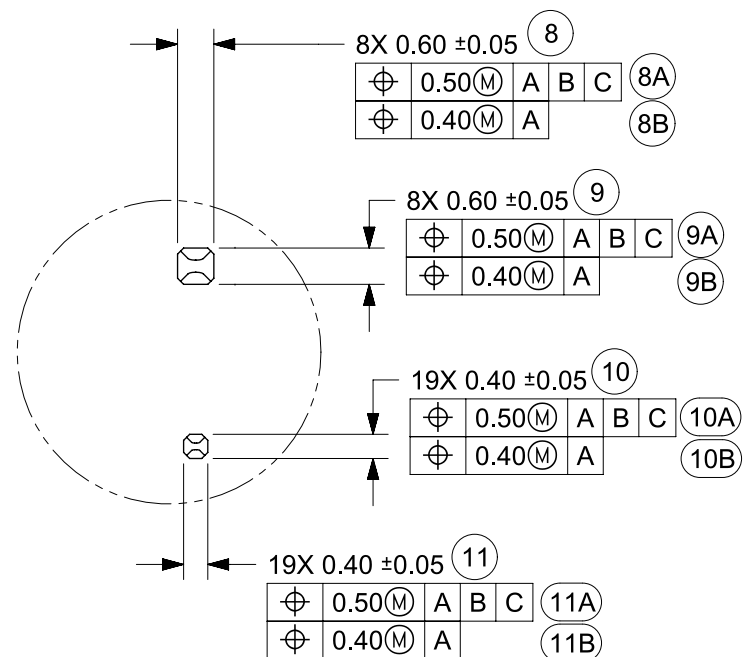

DETAIL A
SCALE 8:1

REVISION	DESCRIPTION
D1	TITLE BLOCK UPDATE
D	UPDATED THE PACKAGING DETAILS
C1	ADDED PCB HOLE DIMENSIONAL & POSITIONAL TOLERANCE 10-JUNE-2020 YPENG47 ECN:639277

THIS DRAWING CONTAINS INFORMATION THAT IS PROPRIETARY TO MOLEX ELECTRONIC TECHNOLOGIES, LLC AND SHOULD NOT BE USED WITHOUT WRITTEN PERMISSION																																																																																																														
FUNCTIONAL SYMBOLS	DIMENSION UNITS	SCALE	CURRENT REV DESC: SEE REVISION TABLE																																																																																																											
$\sqrt{A} = 0$	MM	1:1	<table border="1"> <tr> <td colspan="4" rowspan="2"> molex STAK50H MOD HDR 27 VERT SOLDER </td> <td colspan="3">PRODUCT SALES DRAWING</td> </tr> <tr> <td>DOCUMENT NUMBER</td> <td>DOC TYPE</td> <td>DOC PART</td> <td>REVISION</td> </tr> <tr> <td>$\sqrt{E} = 0$</td> <td colspan="2">GENERAL TOLERANCES (UNLESS SPECIFIED)</td> <td colspan="2">2024-01-09</td> <td colspan="2">2005011270SD</td> <td>PSD</td> <td>000</td> <td>D1</td> </tr> <tr> <td>$\sqrt{E} = 0$</td> <td colspan="2">ANGULAR TOL ±</td> <td colspan="2">2024-01-12</td> <td colspan="2">SEE TABLE</td> <td colspan="2"></td> <td></td> </tr> <tr> <td></td> <td colspan="2">4 PLACES ±</td> <td colspan="2">2024-01-12</td> <td colspan="2"></td> <td colspan="2"></td> <td></td> </tr> <tr> <td>DIVISIONAL SYMBOLS</td> <td colspan="2">3 PLACES ±</td> <td colspan="2">STATUS: Production</td> <td colspan="2">MATERIAL NUMBER</td> <td colspan="2">CUSTOMER</td> <td>SHEET NUMBER</td> </tr> <tr> <td></td> <td colspan="2">2 PLACES ± 0.130</td> <td colspan="2">DRWN: Praveen Kumar S</td> <td colspan="2">SEE TABLE</td> <td colspan="2"></td> <td>2 OF 2</td> </tr> <tr> <td></td> <td colspan="2">1 PLACE ± 0.25</td> <td colspan="2">CHK'D: Kun Du</td> <td colspan="2"></td> <td colspan="2"></td> <td></td> </tr> <tr> <td></td> <td colspan="2">0 PLACES ±</td> <td colspan="2">APPR: Ringo Hu</td> <td colspan="2"></td> <td colspan="2"></td> <td></td> </tr> <tr> <td></td> <td colspan="2">DRAFT WHERE APPLICABLE MUST REMAIN WITHIN DIMENSIONS</td> <td>THIRD ANGLE PROJECTION</td> <td>DRAWING</td> <td>SERIES</td> <td colspan="2"></td> <td colspan="2"></td> </tr> <tr> <td></td> <td></td> <td></td> <td></td> <td>B-SIZE</td> <td>200501</td> <td colspan="2"></td> <td colspan="2"></td> </tr> </table>							molex STAK50H MOD HDR 27 VERT SOLDER				PRODUCT SALES DRAWING			DOCUMENT NUMBER	DOC TYPE	DOC PART	REVISION	$\sqrt{E} = 0$	GENERAL TOLERANCES (UNLESS SPECIFIED)		2024-01-09		2005011270SD		PSD	000	D1	$\sqrt{E} = 0$	ANGULAR TOL ±		2024-01-12		SEE TABLE						4 PLACES ±		2024-01-12							DIVISIONAL SYMBOLS	3 PLACES ±		STATUS: Production		MATERIAL NUMBER		CUSTOMER		SHEET NUMBER		2 PLACES ± 0.130		DRWN: Praveen Kumar S		SEE TABLE				2 OF 2		1 PLACE ± 0.25		CHK'D: Kun Du								0 PLACES ±		APPR: Ringo Hu								DRAFT WHERE APPLICABLE MUST REMAIN WITHIN DIMENSIONS		THIRD ANGLE PROJECTION	DRAWING	SERIES									B-SIZE	200501				
molex STAK50H MOD HDR 27 VERT SOLDER														PRODUCT SALES DRAWING																																																																																																
										DOCUMENT NUMBER	DOC TYPE	DOC PART	REVISION																																																																																																	
$\sqrt{E} = 0$	GENERAL TOLERANCES (UNLESS SPECIFIED)									2024-01-09		2005011270SD		PSD	000	D1																																																																																														
$\sqrt{E} = 0$	ANGULAR TOL ±		2024-01-12		SEE TABLE																																																																																																									
	4 PLACES ±		2024-01-12																																																																																																											
DIVISIONAL SYMBOLS	3 PLACES ±		STATUS: Production		MATERIAL NUMBER		CUSTOMER		SHEET NUMBER																																																																																																					
	2 PLACES ± 0.130		DRWN: Praveen Kumar S		SEE TABLE				2 OF 2																																																																																																					
	1 PLACE ± 0.25		CHK'D: Kun Du																																																																																																											
	0 PLACES ±		APPR: Ringo Hu																																																																																																											
	DRAFT WHERE APPLICABLE MUST REMAIN WITHIN DIMENSIONS		THIRD ANGLE PROJECTION	DRAWING	SERIES																																																																																																									
				B-SIZE	200501																																																																																																									