

MATERIAL NO.	PART NO.	COLOR
130145-0017	26T75	BLACK
130145-0018	26T75YL	YELLOW

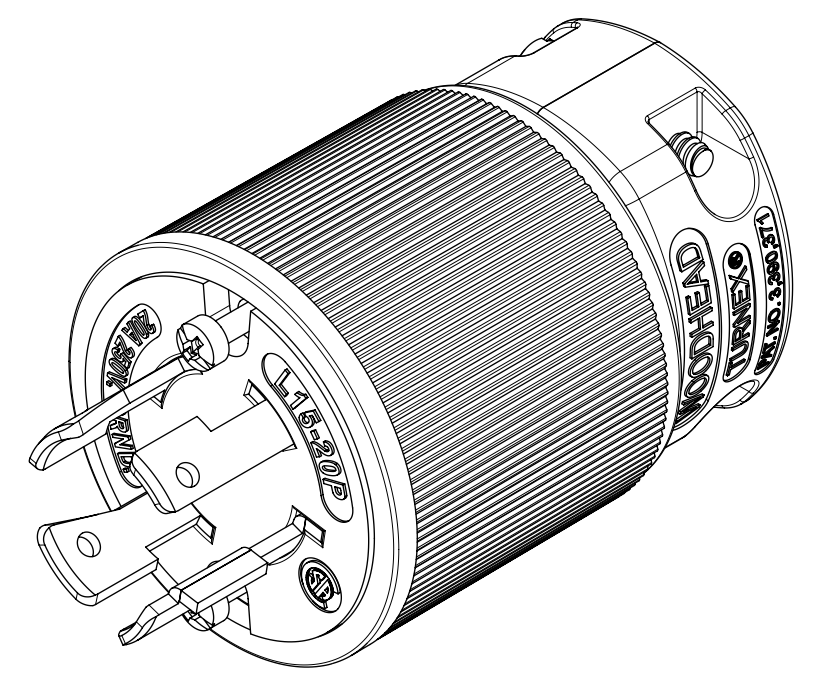

FACE VIEW

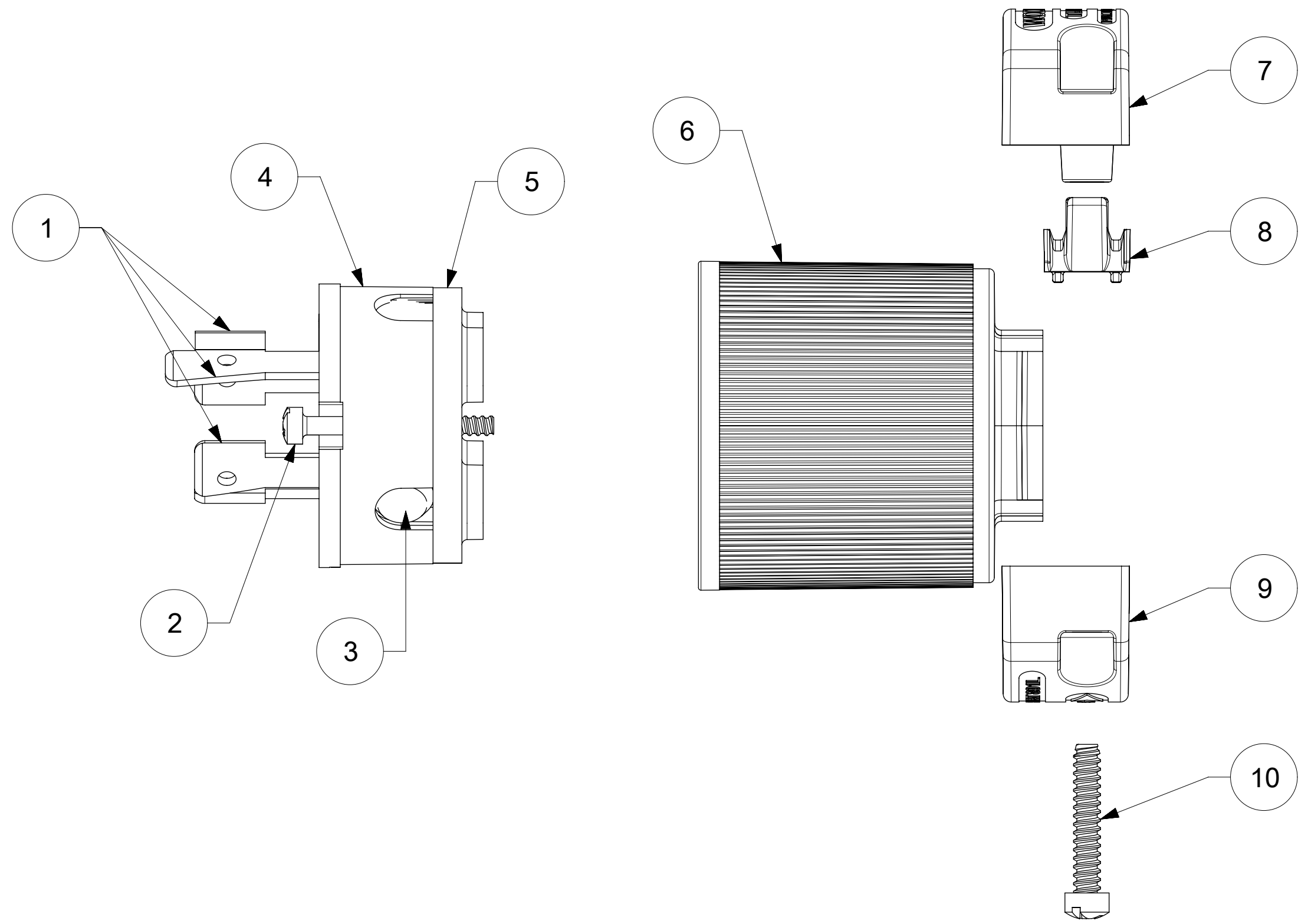
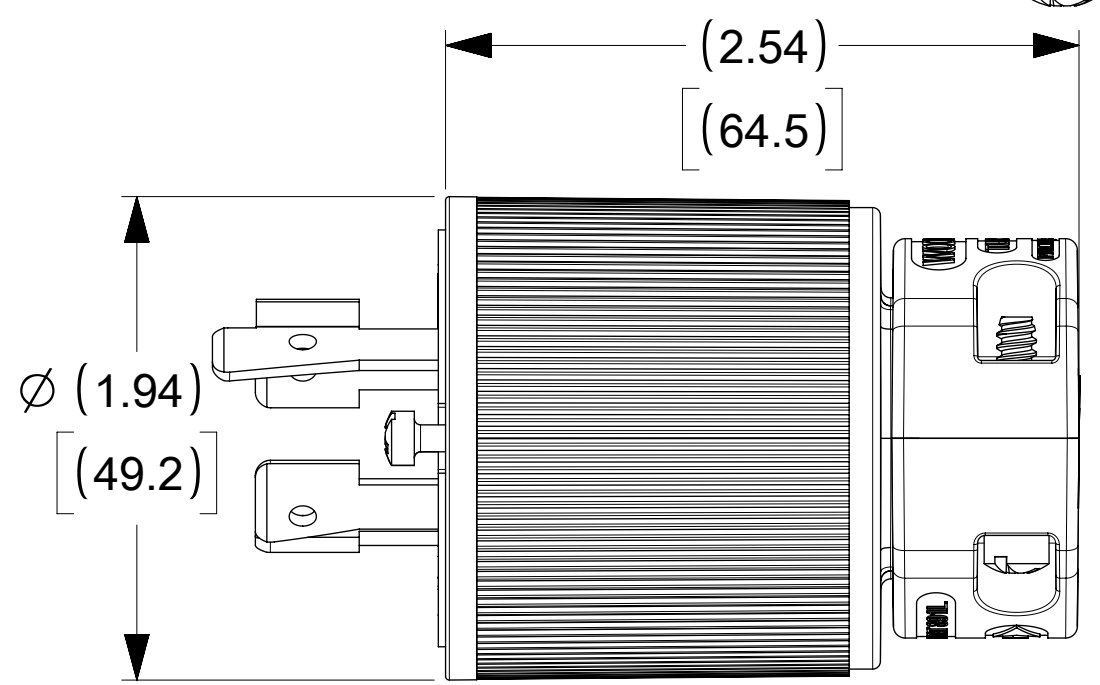
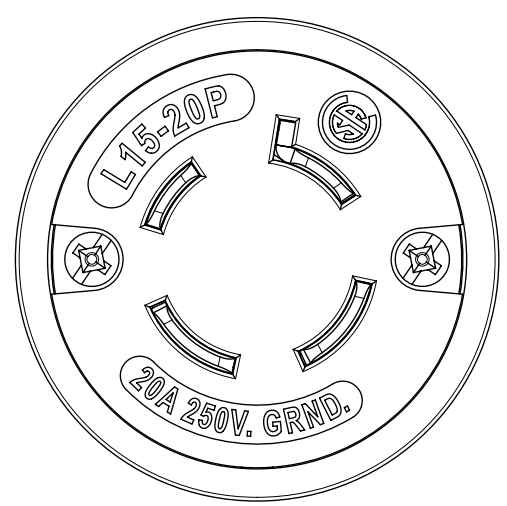

WIRING TERMINATION

GREEN COLOR
(GREEN WIRE)

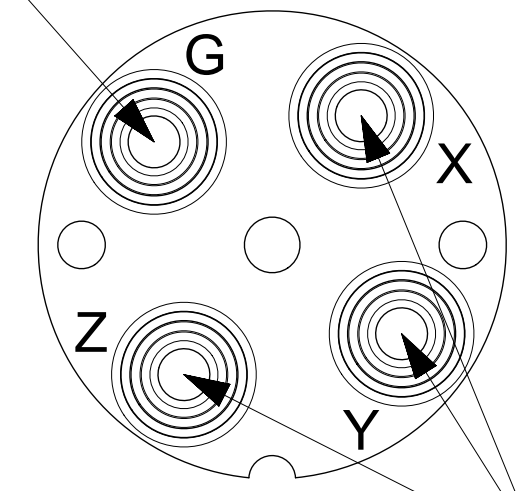

BRASS COLOR
(HOT/PHASE WIRE)

ITEM NO.	DESCRIPTIONS	MATERIAL	QTY.
1	BLADES	BRASS, NICKEL PLATED	4
2	RETAINING SCREWS	STAINLESS STEEL	2
3	TERMINAL SCREWS/CLAMP ASSEMBLY	BRASS, ZINC PLATED	4
4	INSERT	NYLON	1
5	TERMINAL COVER	POLYCARBONATE	1
6	HOUSING	NYLON	1
7	CLAMP CORD MALE	NYLON	1
8	CLAMP CORD INSERT	NYLON	1
9	CLAMP CORD FEMALE	NYLON	1
10	RETAINING SCREWS	STAINLESS STEEL	2

SYMBOLS		THIS DRAWING CONTAINS INFORMATION THAT IS PROPRIETARY TO MOLEX ELECTRONIC TECHNOLOGIES, LLC AND SHOULD NOT BE USED WITHOUT WRITTEN PERMISSION	
$\nabla = 0$	DIMENSION UNITS	SCALE	CURRENT REV DESC: NEW RELEASE
$\nabla = 0$	INCH[MM]	NTS	
$\nabla = 0$	GENERAL TOLERANCES (UNLESS SPECIFIED)		
$\nabla = 0$		MM	INCH
$\nabla = 0$	4 PLACES	±	±
$\nabla = 0$	3 PLACES	±	±
$\nabla = 0$	2 PLACES	±	±
$\nabla = 0$	1 PLACE	±	±
$\nabla = 0$	0 PLACES	±	±
$\nabla = 0$	ANGULAR TOL	± °	
$\nabla = 0$	DRAFT WHERE APPLICABLE MUST REMAIN WITHIN DIMENSIONS	THIRD ANGLE PROJECTION	DRAWING SERIES
			C-SIZE 130145
			EC NO: 626991
			DRWN: DSOPPIN 2019/04/10
			CHK'D: DNGUYEN62 2019/12/27
			APPR: HKNEELAND 2020/02/04
			INITIAL REVISION:
			DRWN: DSOPPIN 2019/04/10
			APPR: HKNEELAND 2020/02/04
			DOCUMENT NUMBER
			1301450017
			DOC TYPE DOC PART REVISION
			PSD 000 A
			MATERIAL NUMBER CUSTOMER SHEET NUMBER
			SEE TABLE GENERAL MARKET 1 OF 1