

ORDER NO.	WOODHEAD NO.	COLOR
130142-0025	2775	YELLOW

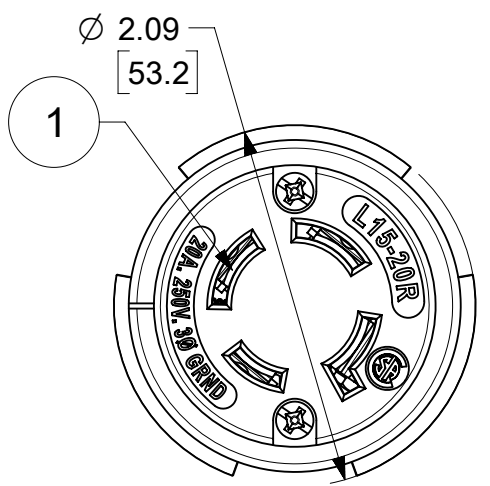

WIRING TERMINATION

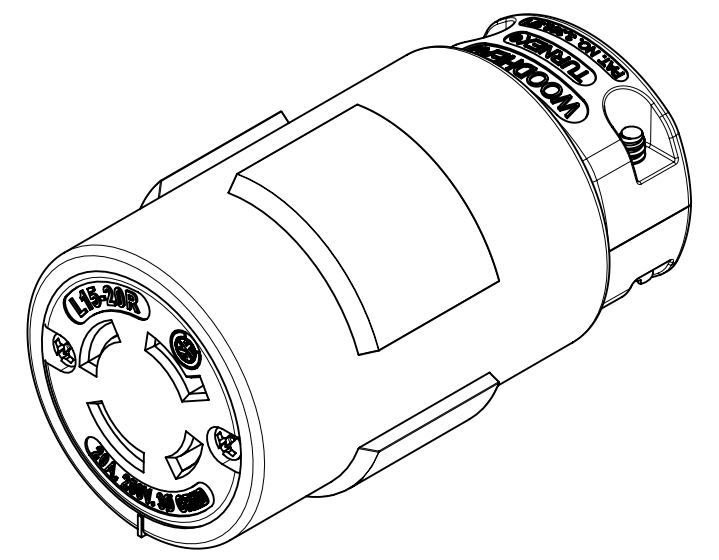
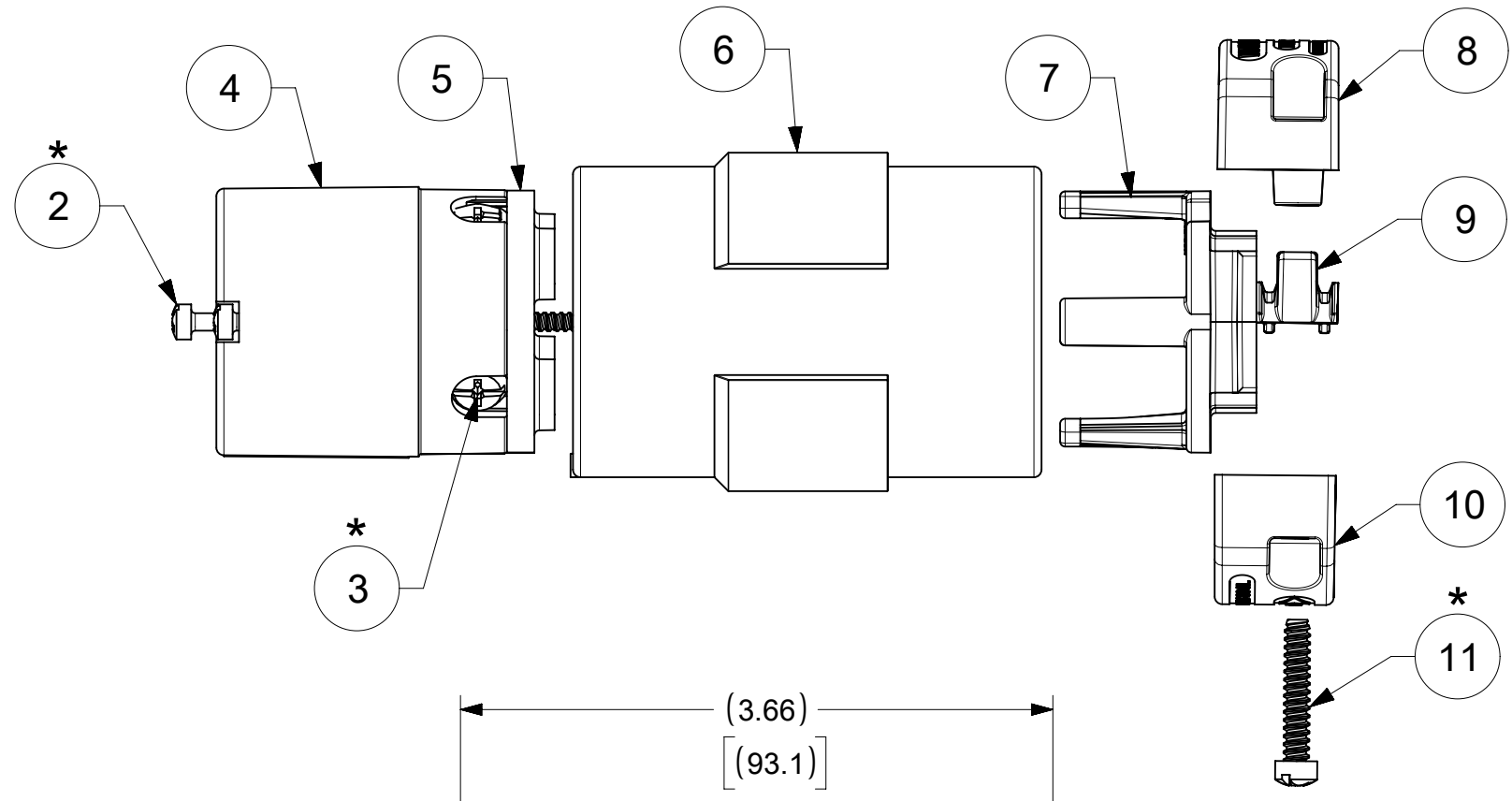
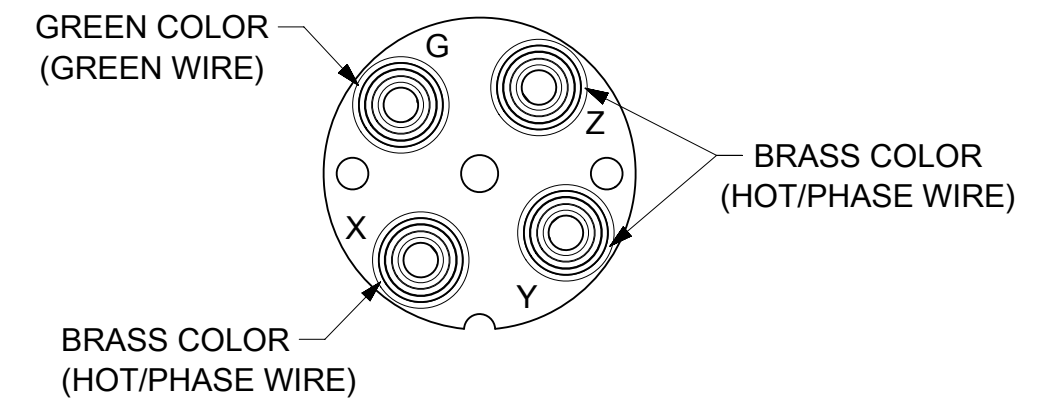

* FOR SCREW TORQUE, SEE ASSEMBLY INSTRUCTIONS

ITEM NO.	DESCRIPTIONS	MATERIAL	QTY.
1	CLIP ASSEMBLY	BRASS, NICKEL PLATED	4
2	RETAINING SCREWS	STAINLESS STEEL	2
3	TERMINAL SCREWS/CLAMP ASSEMBLY	BRASS, ZINC PLATED	4
4	INSERT	NYLON	1
5	TERMINAL COVER	POLYCARBONATE	1
6	CONNECTOR HUSK	RUBBER	1
7	CLAMP SUPPORT	NYLON	1
8	CLAMP CORD MALE	NYLON	1
9	CLAMP CORD INSERT	NYLON	1
10	CLAMP CORD FEMALE	NYLON	1
11	RETAINING SCREWS	STAINLESS STEEL	2

SYMBOLS		THIS DRAWING CONTAINS INFORMATION THAT IS PROPRIETARY TO MOLEX ELECTRONIC TECHNOLOGIES, LLC AND SHOULD NOT BE USED WITHOUT WRITTEN PERMISSION	
▽ = 0	DIMENSION UNITS	SCALE	CURRENT REV DESC: NEW RELEASE
▽ = 0	INCH/MM	NTS	
▽ = 0	GENERAL TOLERANCES (UNLESS SPECIFIED)		<p>molex</p> <p>SUPER-SAFEWAY CONN NEMA 3P4W L15-20R</p> <p>PRODUCT CUSTOMER DRAWING</p> <p>DOCUMENT NUMBER: 1301420025 DOC TYPE: PSD DOC PART: 000 REVISION: A</p> <p>MATERIAL NUMBER: SEE TABLE CUSTOMER: GENERAL MARKET SHEET NUMBER: 1 OF 1</p>
▽ = 0	4 PLACES ±	MM INCH	
▽ = 0	3 PLACES ±		
▽ = 0	2 PLACES ±		
▽ = 0	1 PLACE ±		
▽ = 0	0 PLACES ±		<p>EC NO: 628052</p> <p>DRWN: VHANDI 2019/06/27</p> <p>CHK'D: DNGUYEN62 2020/02/14</p> <p>APPR: HKNEELAND 2020/06/02</p>
▽ = 0	ANGULAR TOL ± °		<p>INITIAL REVISION:</p> <p>DRWN: VHANDI 2019/06/27</p> <p>APPR: HKNEELAND 2020/06/02</p>
▽ = 0	DRAFT WHERE APPLICABLE MUST REMAIN WITHIN DIMENSIONS	THIRD ANGLE PROJECTION	<p>DRAWING: B-SIZE</p> <p>SERIES: 130142</p>