

ORDER NO.	WOODHEAD NO.	COLOR
130141-0020	1448	YELLOW

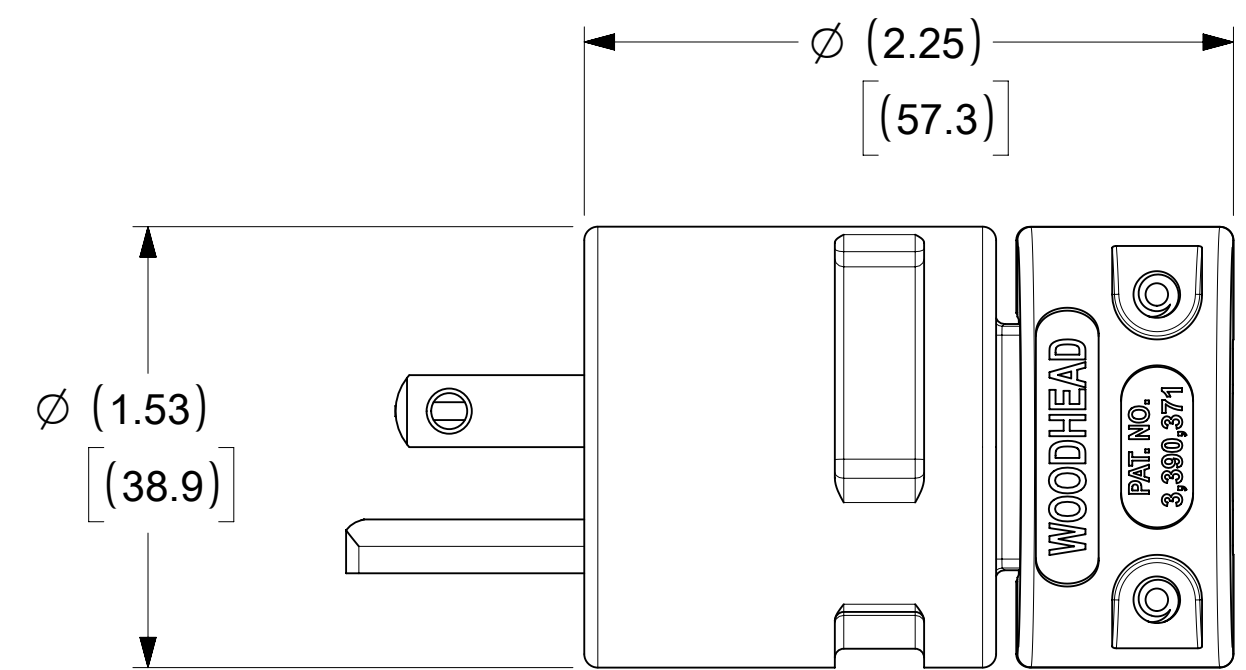

WIRING TERMINATION

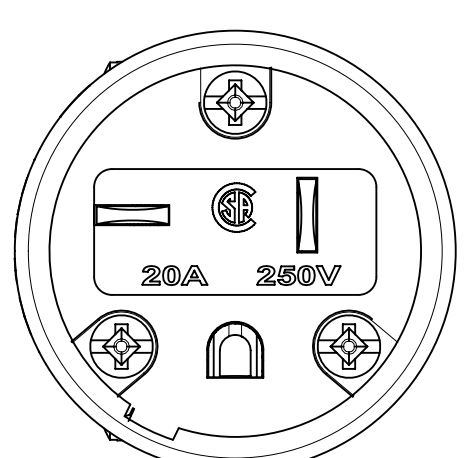
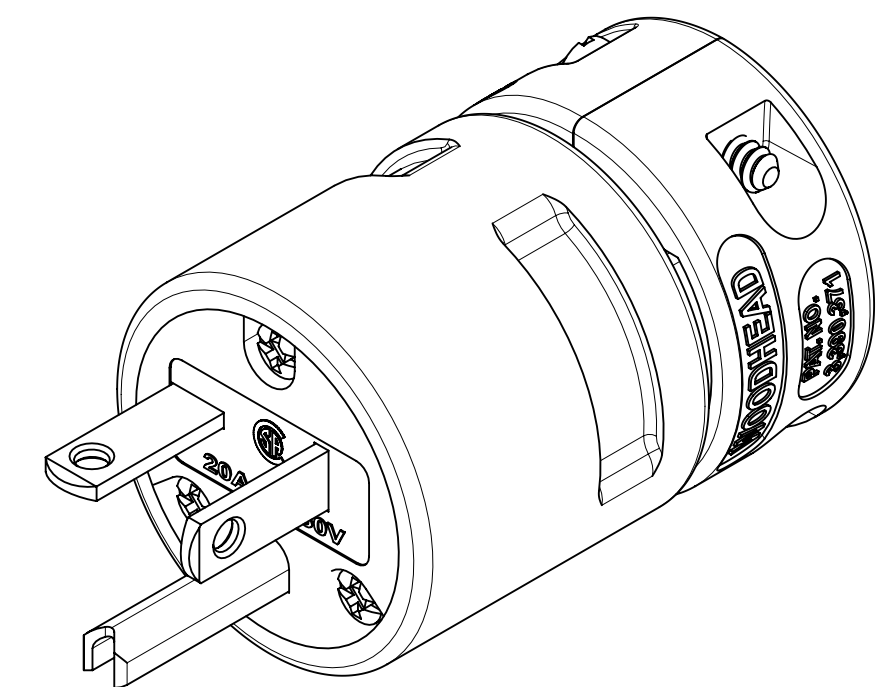
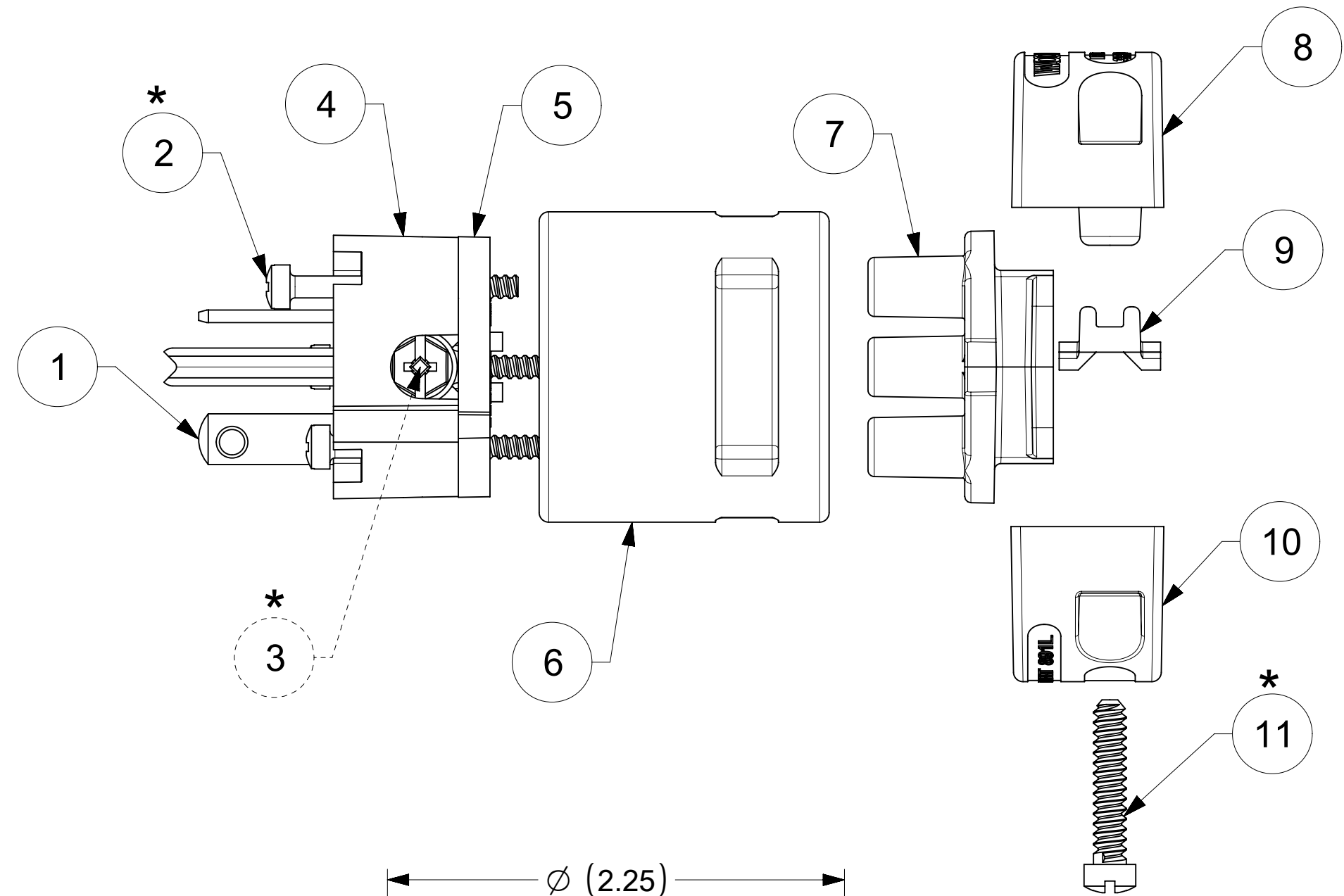
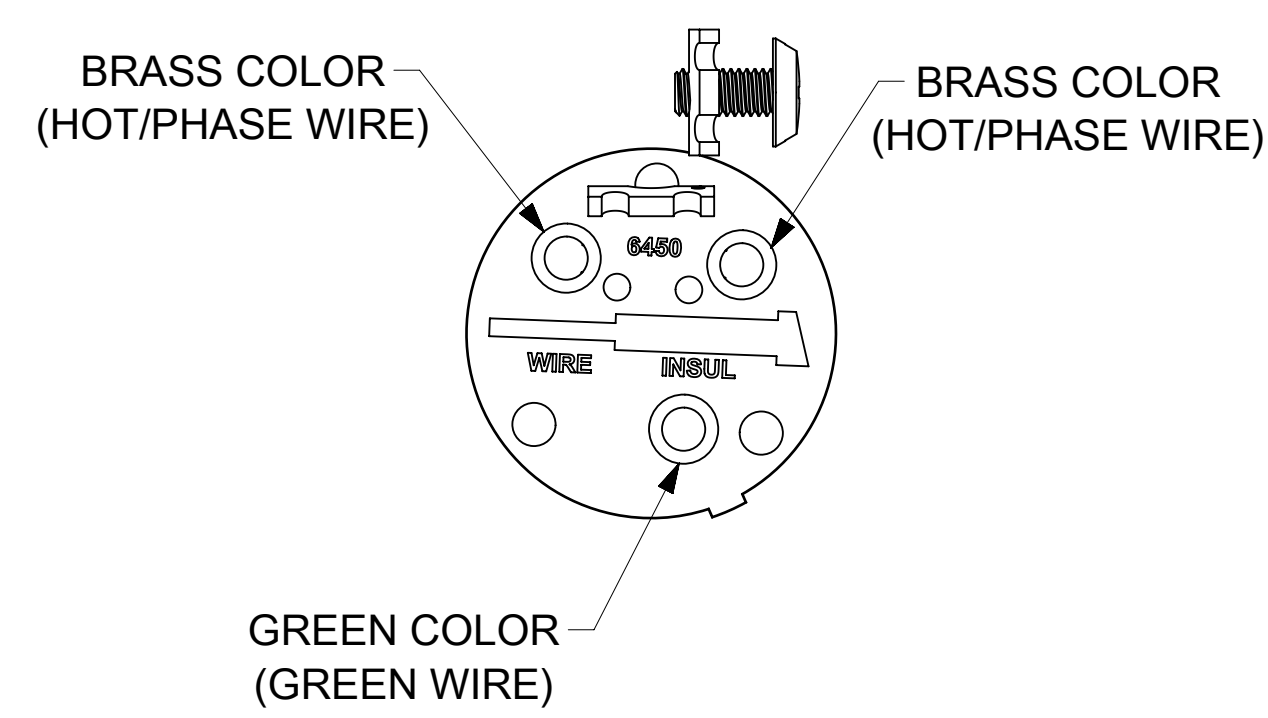

* FOR SCREW TORQUE, SEE ASSEMBLY INSTRUCTIONS

ITEM NO.	DESCRIPTIONS	MATERIAL	QTY.
1	BLADES	BRASS, NICKEL PLATED	3
2	RETAINING SCREWS	STAINLESS STEEL	3
3	TERMINAL SCREWS/CLAMP ASSEMBLY	BRASS, ZINC PLATED	3
4	INSERT; YELLOW	NYLON	1
5	TERMINAL COVER	POLYCARBONATE	1
6	HOUSING; YELLOW	NYLON	1
7	CLAMP SUPPORT; YELLOW	NYLON	1
8	CLAMP CORD MALE; YELLOW	NYLON	1
9	CLAMP CORD INSERT	NYLON	1
10	CLAMP CORD FEMALE; YELLOW	NYLON	1
11	RETAINING SCREWS	STEEL ZINC PLATED	2

SYMBOLS DIMENSION UNITS: INCH/MM SCALE: NTS CURRENT REV DESC: NEW RELEASE GENERAL TOLERANCES (UNLESS SPECIFIED): 4 PLACES: ± 3 PLACES: ± 2 PLACES: ± 1 PLACE: ± 0 PLACES: ± ANGULAR TOL: ± ° DRAFT WHERE APPLICABLE MUST REMAIN WITHIN DIMENSIONS THIRD ANGLE PROJECTION DRAWING SERIES: C-SIZE 130141	THIS DRAWING CONTAINS INFORMATION THAT IS PROPRIETARY TO MOLEX ELECTRONIC TECHNOLOGIES, LLC AND SHOULD NOT BE USED WITHOUT WRITTEN PERMISSION		molex SUPER-SAFEWAY PLUG NEMA 6-20 2P3W PRODUCT CUSTOMER DRAWING	
	EC NO: 621242 DRWN: VHANDI 2019/06/11 CHK'D: DNGUYEN62 2020/02/14 APPR: HKNEELAND 2020/09/03 INITIAL REVISION: DRWN: VHANDI 2019/06/11 APPR: HKNEELAND 2020/09/03	DOCUMENT NUMBER: 1301410020 DOC TYPE: PSD DOC PART: 000 REVISION: A	MATERIAL NUMBER: SEE TABLE CUSTOMER: GENERAL MARKET	SHEET NUMBER: 1 OF 1