

1. DESCRIPTION

These devices contain two independent 4-input NAND gates.

The XL74LS10,XD74LS10 are characterized for operation from 0°C to 70°C.

2. PIN CONFIGURATIONS

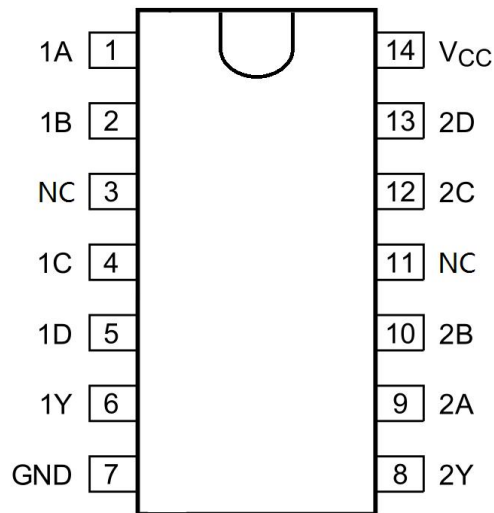

3. LOGIC DIAGRAM

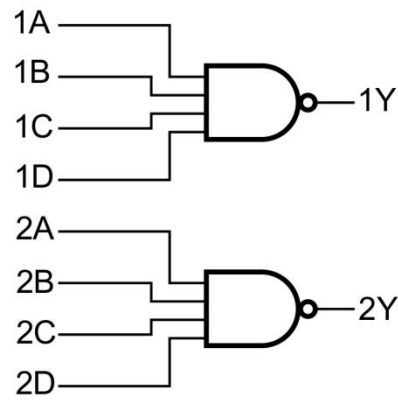

INPUTS				OUTPUT
A	B	C	D	Y
H	H	H	H	L
L	X	X	X	H
X	L	X	X	H
X	X	L	X	H
X	X	X	L	H

4. SCHEMATICS (each gate)

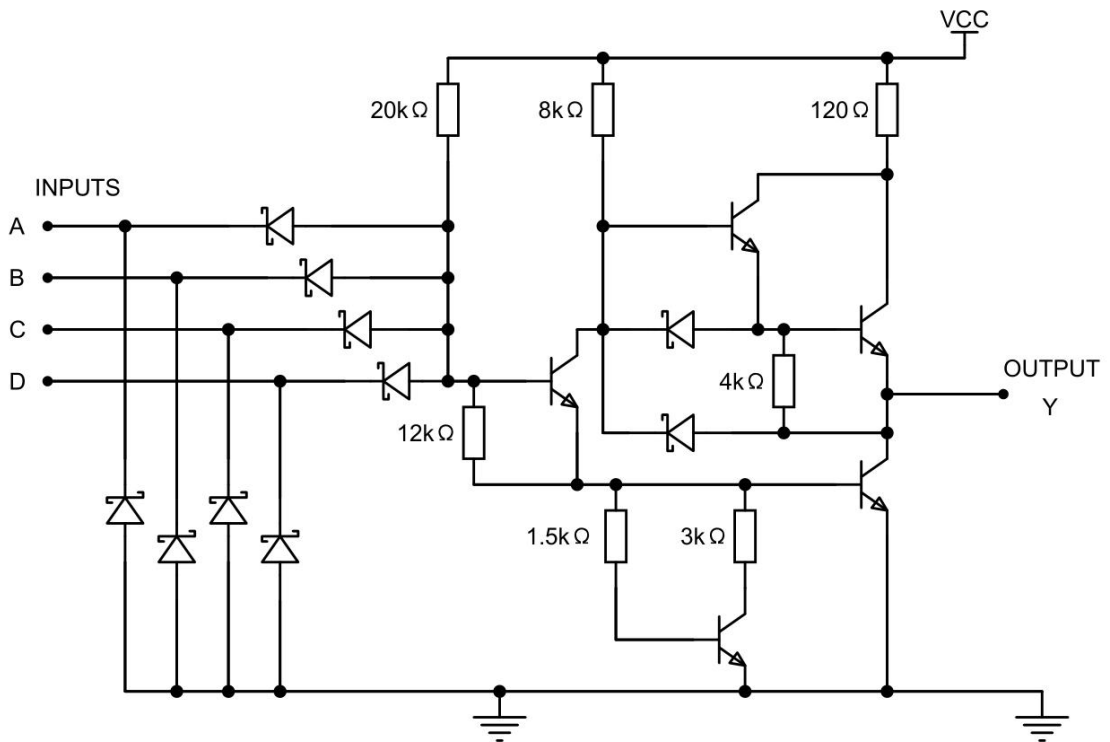

5. ABSOLUTE MAXIMUM RATINGS OVER OPERATING FREE-AIR TEMPERATURE RANGE (UNLESS OTHERWISE NOTES)

Supply voltage, V_{CC} (see Note 1).....	7V
Input voltage, V_I : 74LS20.....	7V
Operating free-air temperature range: SOP package.....	0°C to 70°C
DIP package.....	0°C to 70°C
Storage temperature range, T_{stg}	-65°C to 150°C

NOTE 1 : Voltage values are with respect to network ground terminals.

6. RECOMMENDED OPERATING CONDITIONS (SEE NOTE 3)

		XL/XD74LS20			UNIT
		MIN	NOM	MAX	
V _{CC}	Supply voltage	4.75	5	5.25	V
V _{IH}	High-level input voltage	2			V
V _{IL}	Low-level input voltage			0.8	V
I _{OH}	High-level output current			-0.4	mA
I _{OL}	Low-level output current			8	mA
T _A	Operating free-air temperature	0		70	°C

7. ELECTRICAL CHARACTERISTICS OVER RECOMMENDED OPERATING FREE-AIR RANGE (UNLESS OTHERWISE NOTED)

PARAMETER	TEST CONDITIONS [†]	XL/XD74LS20			UNIT
		MIN	TYP [‡]	MAX	
V _{IK}	V _{CC} = MIN, I _I = -18 mA			-1.5	V
V _{OH}	V _{CC} = MIN, V _{IL} = MAX, I _{OH} = -0.4 mA	2.7	3.4		V
V _{OL}	V _{CC} = MIN, V _{IH} = 2 V			0.4	V
		I _{OL} = 4 mA	I _{OL} = 8 mA	0.25	
I _I	V _{CC} = MAX, V _I = 7 V			0.1	mA
I _{IH}	V _{CC} = MAX, V _I = 2.7 V			20	μA
I _{IL}	V _{CC} = MAX, V _I = 0.4 V			-0.4	mA
I _{OS} [§]	V _{CC} = MAX	-20		-100	mA
I _{CCH}	V _{CC} = MAX, V _I = 4.5 V		0.4	0.8	mA
I _{CCL}	V _{CC} = MAX, V _I = 0 V		1.2	2.2	mA

[†] For conditions shown as MIN or MAX, use the appropriate value specified under recommended operating conditions.

[‡] All typical values are at V_{CC} = 5 V, T_A = 25°C.

[§] Not more than one output should be shorted at a time, and the duration of the short-circuit should not exceed one second.

8. SWITCHING CHARACTERISTICS, V_{CC} = 5 V, T_A = 25 °C (see Figure 2)

PARAMETER	FROM (INPUT)	TO (OUTPUT)	TEST CONDITIONS	XL/XD74LS20			UNIT
				MIN	TYP	MAX	
t _{PLH}	Any	Y	R _L = 2 kΩ, C _L = 15 pF		9	15	ns
t _{PHL}					10	15	

NOTE 2: Load circuits and voltage waveforms are shown in Section 1.

9. ORDERING INFORMATION

Ordering Information

Part Number	Device Marking	Package Type	Body size (mm)	Temperature (°C)	MSL	Transport Media	Package Quantity
XL74LS20	XL74LS20	SOP14	8.75 * 4.00	-0 to 70	MSL3	T&R	2500
XD74LS20	XD74LS20	DIP14	19.05 * 6.35	-0 to 70	MSL3	Tube 25	1000

10. DIMENSIONAL DRAWINGS

SOP14

Mark	Size	Min (mm)	Max (mm)	Mark	Size	Min (mm)	Max (mm)
A		8.55	8.75	C4		0.193	0.213
A1		0.356	0.456	D		0.95	1.15
A2		1.27TYP		D1		0.40	0.70
A3		0.312TYP		D2		0.20TYP	
B		3.80	4.00	R1		0.20TYP	
B1		5.80	6.20	R2		0.20TYP	
C		1.40	1.60	θ1		8° ~ 12° TYP4	
C1		0.60	0.70	θ2		8° ~ 12° TYP4	
C2		0.55	0.65	θ3		0° ~ 8°	
C3		0.05	0.25	θ4		4° ~ 12°	

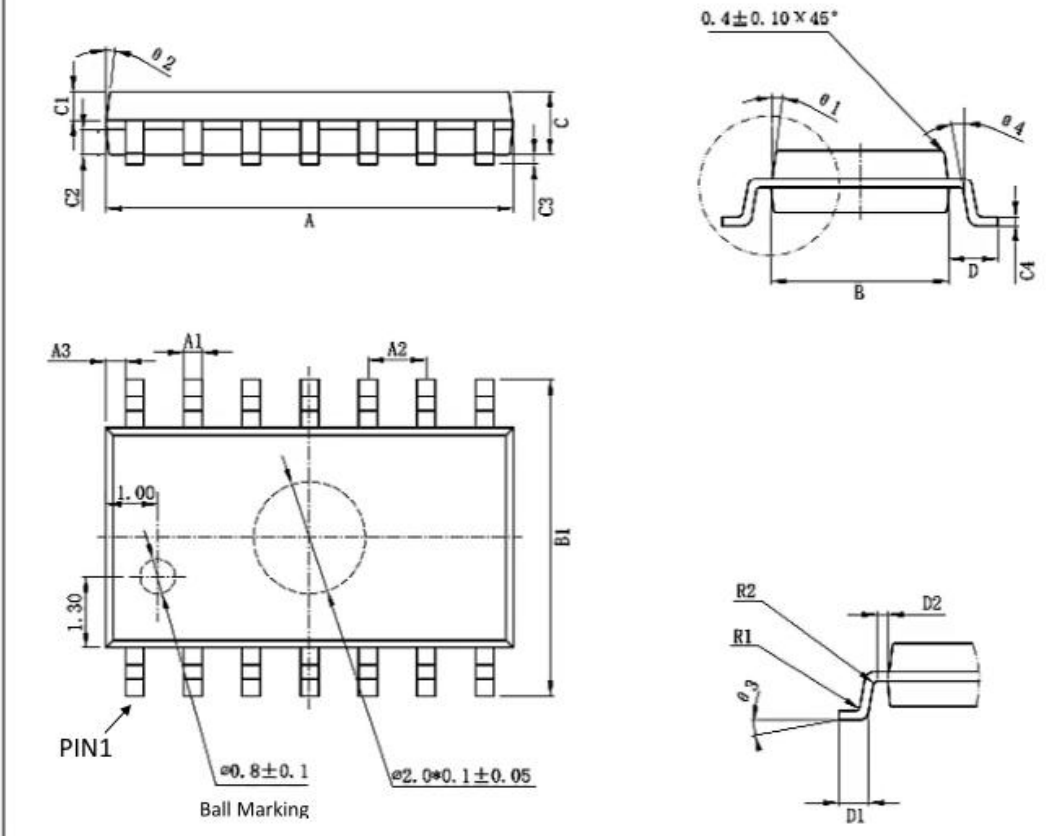

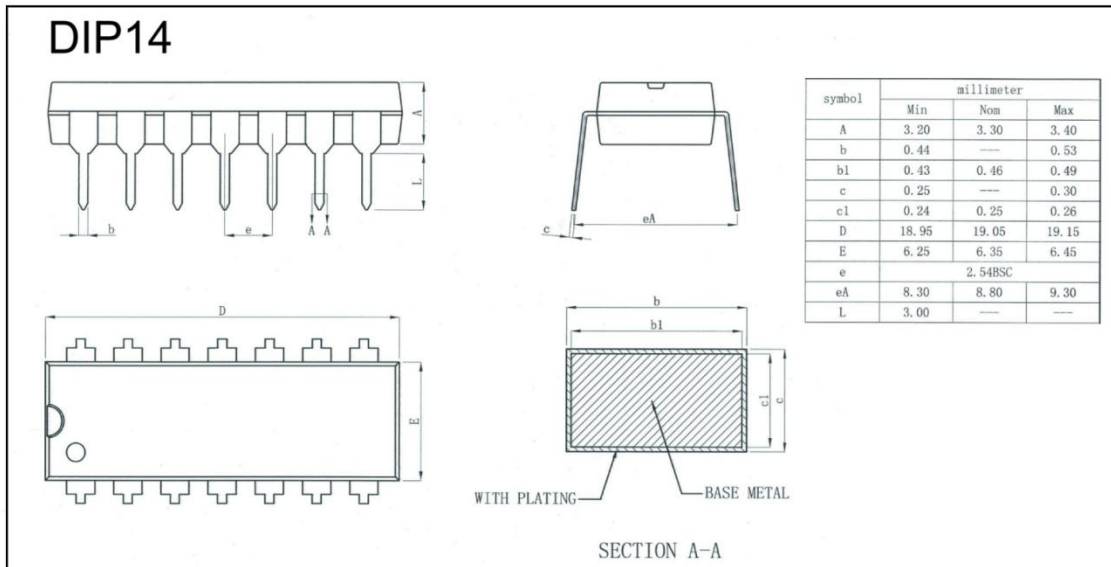

[if you need help contact us. Xinluda reserves the right to change the above information without prior notice]