

## General Description

The EA8212L is a 2A buck regulator, designed to operate from 4.5V to 16V input voltage range. Built-in low  $R_{DS(ON)}$  high/low side Power-MOSFETS not only reduce external components and has up to 96% efficiency, ideal for 2A output current applications. The EA8212L is designed to take into account the light load mode operation. At output loading 20mA condition, the efficiency up to 80%. The EA8212L has complete protection functions, including cycle-by-cycle current limit, short circuit protection, OTP and UVLO protection. The internal compensation design not only allows users to more simplified application, and can reduce the cost of external components. The EA8212L is available in the SOT-23-6 package and easy to use.

## Features

- ▶ Built-in Low  $R_{DS(ON)}$  Power-MOSFETS
- ▶ Efficiency Up to 96%
- ▶ Light Load Efficiency Up to 80%
- ▶ 4.5V to 16V Input Voltage Range
- ▶ Output Adjustable Down to 0.6V
- ▶ 2A Continuous Load Current
- ▶ Fixed 600KHz Switching Frequency
- ▶ Internal Compensation
- ▶ Cycle-by-Cycle Current Limit
- ▶ Auto Recovery Hiccup Mode Short Circuit Protection
- ▶ Input UVLO Protection
- ▶ Auto Recovery OTP Protection
- ▶ Available in SOT-23-6 Package

## Applications

- ▶ Distributed Power Systems
- ▶ Netcom Products
- ▶ LCD TVs and Flat TVs
- ▶ Notebooks

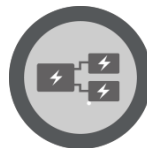

## Pin Configurations



### Pin Description

Pin Name	Function Description	Pin No.
BOOT	The power input of the internal high side N-MOSFET gate driver. Connect a 33nF ceramic capacitor from BOOT pin to SWITCH pin.	1
GND	Ground pin.	2
FBK	Feedback input. Connect FBK pin and GND pin with voltage dividing resistors to set the output voltage.	3
RUN	The device turns on/turns off control input. The EA8212L on/off state can be controlled by RUN pin voltage level. Connect RUN pin to PWR pin with a 150KΩ pull up resistor for automatic startup.	4
PWR	The EA8212L power input pin. Recommended to use two 10uF MLCC capacitors between PWR pin and GND pin.	5
SWITCH	Internal MOSFET switching output. Connect SWITCH pin with a low pass filter circuit to obtain a stable DC output voltage.	6

### Function Block Diagram

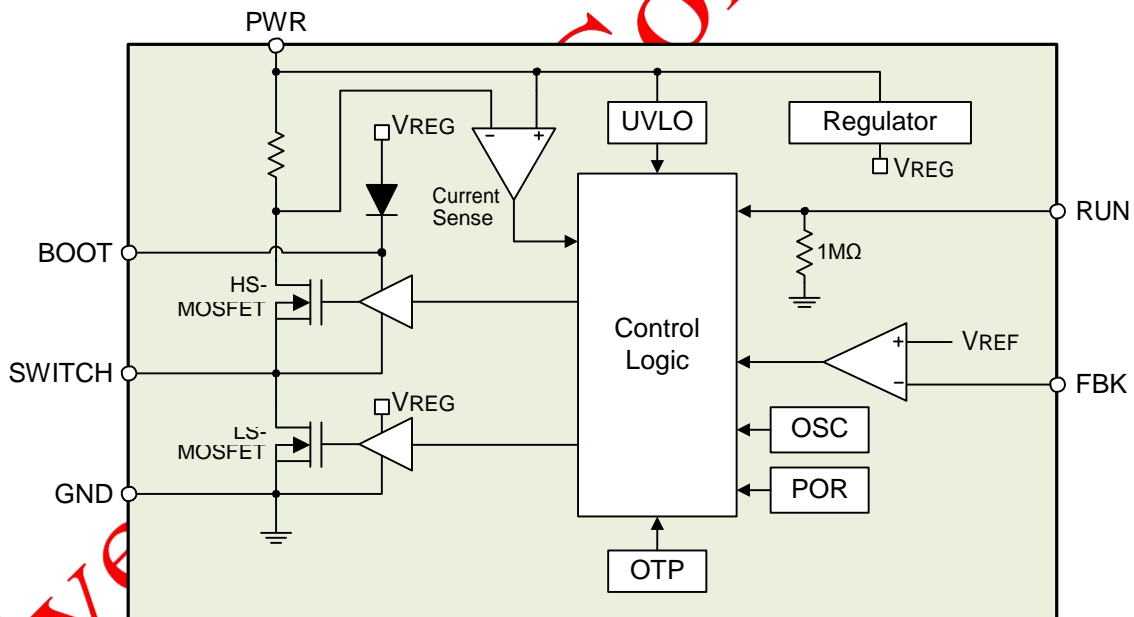

Figure 1. EA8212L internal function block diagram

### Absolute Maximum Ratings

Parameter	Value
Input Voltage ( $V_{PWR}$ )	-0.3V to +17V
RUN Pin Input Voltage ( $V_{RUN}$ )	-0.3V to +17V
BOOT Pin Voltage ( $V_{BOOT}$ )	$V_{SWITCH}-0.3V$ to $V_{SWITCH}+6.3V$
SWITCH Pin Voltage ( $V_{SWITCH}$ )	-1V to +17.5V
FBK Pin Voltage ( $V_{FBK}$ )	-0.3V to +6.3V
Ambient Temperature operating Range ( $T_A$ )	-40°C to +85°C
Maximum Junction Temperature ( $T_{Jmax}$ )	+150°C
Lead Temperature (Soldering, 10 sec)	+260°C
Storage Temperature Range ( $T_s$ )	-65°C to +150°C

Note (1): Stresses beyond those listed under "Absolute Maximum Ratings" may cause permanent damage to the device. Exposure to "Absolute Maximum Ratings" conditions for extended periods may affect device reliability and lifetime.

(2): The EA8212L works normally if the negative voltage is in the -6V range and the time is shorter than 4ns.

### Package Thermal Characteristics

Parameter	Value
SOT-23-6 Thermal Resistance ( $\theta_{JC}$ )	125°C/W
SOT-23-6 Thermal Resistance ( $\theta_{JA}$ )	250°C/W
SOT-23-6 Power Dissipation at $T_A=25^\circ\text{C}$ ( $P_{Dmax}$ )	0.5W

Note (1):  $P_{Dmax}$  is calculated according to the formula:  $P_{Dmax}=(T_{JMAX}-T_A)/\theta_{JA}$ .

### Recommended Operating Conditions

Parameter	Value
Input Voltage ( $V_{PWR}$ )	+4.5V to +16V
RUN Pin Input Voltage ( $V_{RUN}$ )	-0.3V to +16V
Output Voltage ( $V_{OUT}$ )	+0.6V to +9V
Junction Temperature Range ( $T_J$ )	-40°C to +125°C

**Electrical Characteristics**
 $V_{PWR}=12V$ ,  $T_A=25^{\circ}C$ , unless otherwise noted

Parameter	Symbol	Test Conditions	Min	Typ	Max	Unit
Input Voltage	$V_{PWR}$		4.5		16	V
Shutdown Supply Current	$I_{SD}$	$V_{RUN} = 0V$		3	10	$\mu A$
Quiescent Current	$I_Q$	$V_{RUN} = 2V$ , $V_{FBK} = 105\% V_{REF}$ , $I_{LOAD} = 0A$		300	600	$\mu A$
UVLO Threshold	$V_{UVLO}$	$V_{PWR}$ Rising		3.8		V
UVLO Hysteresis	$V_{UV-HYST}$			400		mV
Output Load Current	$I_{LOAD}$				2	A
Reference Voltage	$V_{REF}$	$4.5V \leq V_{PWR} \leq 16V$	0.588	0.6	0.612	V
Switching Frequency	$F_{SW}$		400	600	800	KHz
Input OVP Voltage	$V_{OVP}$			19		V
High Side MOSFET On-Resistance	$R_{DS(ON)-HM}$			90		m $\Omega$
Low Side MOSFET On-Resistance	$R_{DS(ON)-LM}$			70		m $\Omega$
High Side MOSFET Current Limit	$I_{LIM-HM}$		2.5	3		A
High Side MOSFET Leakage Current	$I_{LEAK-HM}$	$V_{RUN} = 0V$ , $V_{SWITCH} = 0V$		1	10	$\mu A$
RUN Pin Input Low Voltage	$V_{RUN-L}$				0.4	V
RUN Pin Input High Voltage	$V_{RUN-H}$		2			V
Maximum Duty Cycle	$D_{MAX}$	$V_{FBK} = 0.5V$		92		%
High Side MOSFET Minimum On Time	$T_{ONMIN}$			60		ns
Internal Soft-Start Time	$t_{SS}$			4		ms
Thermal Shutdown Threshold	$T_{OTP}$			160		$^{\circ}C$
Thermal Shutdown Hysteresis	$T_{HYST}$			30		$^{\circ}C$

Note (1): MOSFET on-resistance specifications are guaranteed by correlation to wafer level measurements.

(2): Thermal shutdown specifications are guaranteed by correlation to the design and characteristics analysis.

**Application Circuit Diagram**

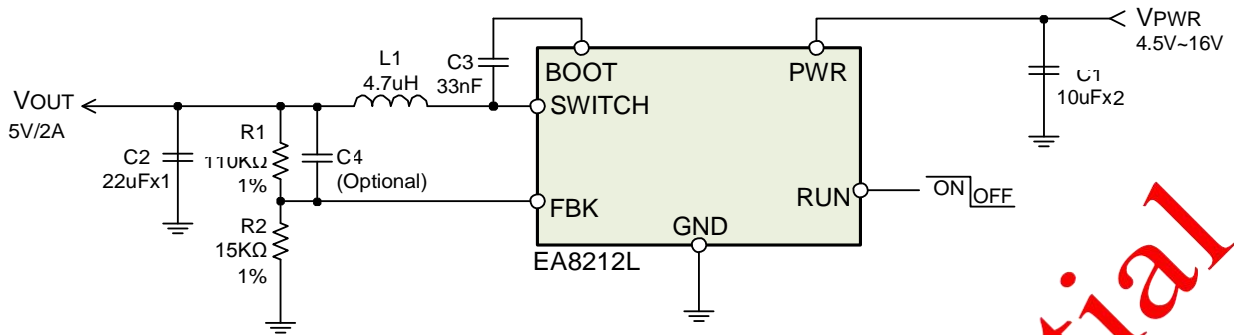

Figure 2. Typical application circuit diagram

**Ordering Information**

Part Number	Package Type	Packing Information
EA8212LT6R	SOT-23-6	Tape & Reel / 3000

Note (1): "T6": Package type code.  
 (2): "R": Tape & Reel.

Everanalog Confidential

### Typical Operating Characteristics

$V_{PWR}=12V$ ,  $V_{OUT}=5V$ ,  $L1=4.7\mu H$ ,  $C1=10F \times 2$ ,  $C2=22\mu F$ ,  $T_A=25^\circ C$ , unless otherwise noted

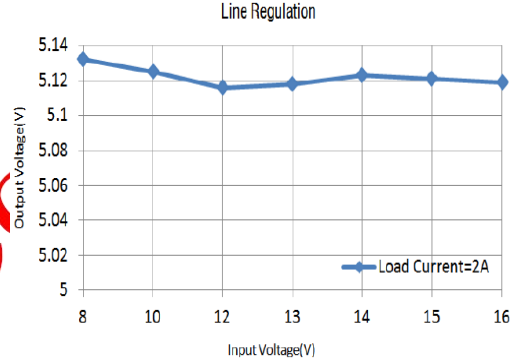
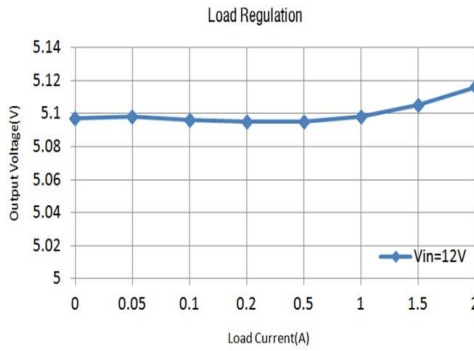
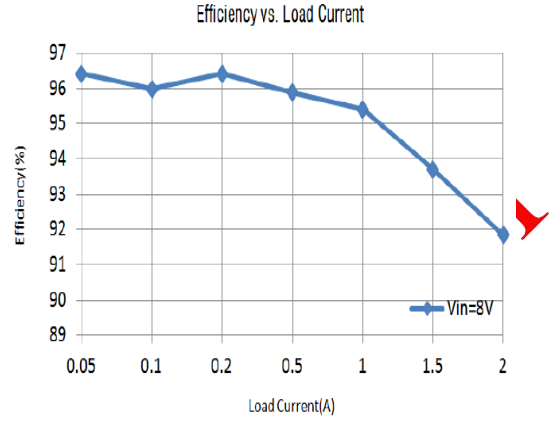
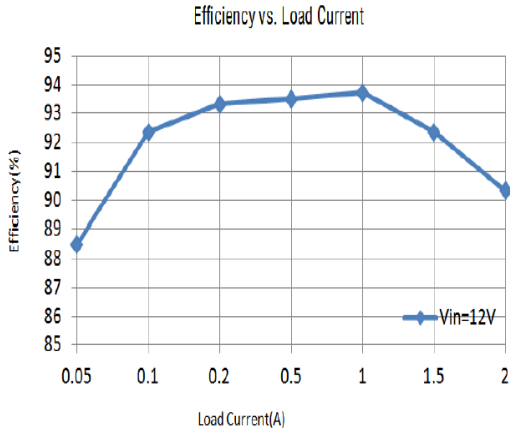

CH1:  $V_{SW}$  CH3:  $V_{OUT} (AC)$

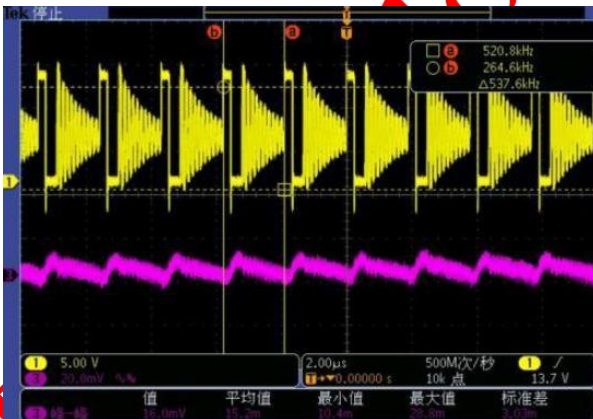

DCM Mode Waveform

CH1:  $V_{SW}$  CH3:  $V_{OUT} (AC)$

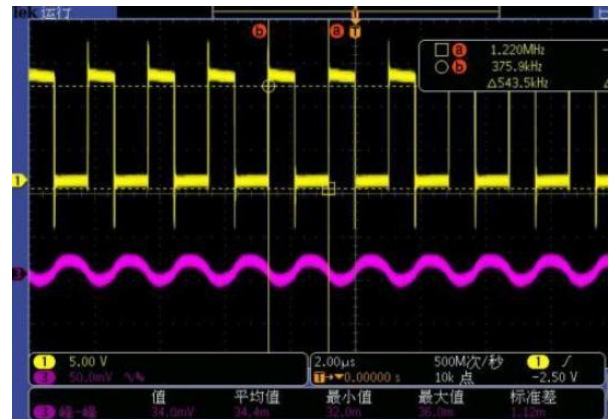

CCM Mode Waveform

## Application Information

### Enable Control

The EA8212L use RUN pin to control the regulator turns on / turns off. When the RUN pin input voltage is higher than 2V, the EA8212L enters the operating mode. Drive the RUN pin input voltage lower than 0.4V to ensure the EA8212L into shutdown mode, as shown in Figure3. When the device works in the shutdown mode, the shutdown supply current is less than 10uA. The EA8212L also provides automatic startup function as shown in Figure 4. Connect RUN pin and PWR pin with a 150KΩ resistor, when the PWR supply input voltage increasing and higher than RUN pin threshold voltage, the EA8212L will enter operating mode automatically.

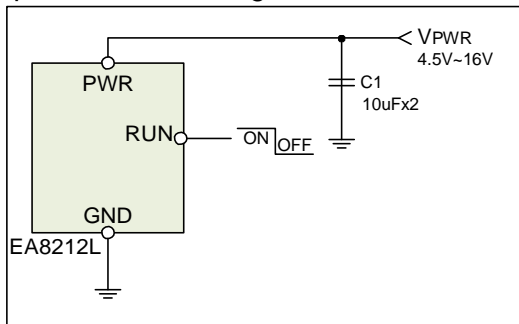

Figure 3. Enable control by RUN pin voltage

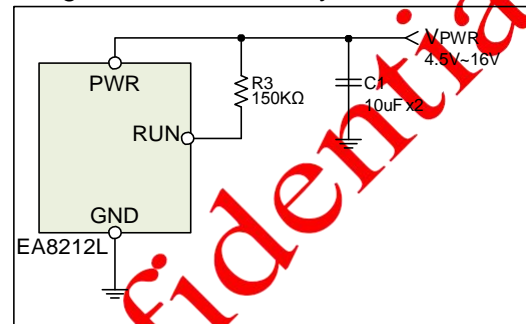

Figure 4. Automatic startup application circuit

### Output Voltage Setting

The EA8212L output voltage can be set via a resistor divider (R1, R2). The output voltage is calculated by following equation:

$$V_{OUT} = 0.6 \times \frac{R1}{R2} + 0.6 \text{ V}$$

Taking into account the loop stability, R1 resistance value must be greater than 100KΩ. The following table lists common output voltage and the corresponding R1, R2 resistance value for reference.

Output Voltage	R1 Resistance	R2 Resistance	Tolerance
5V	220KΩ	30KΩ	1%
3.3V	510KΩ	110KΩ	1%
1.8V	200KΩ	100KΩ	1%
1.2V	100KΩ	100KΩ	1%

### Input / Output Capacitors Selection

The input capacitors are used to suppress the noise amplitude of the input voltage and provide a stable and clean DC input to the device. Because the ceramic capacitor has low ESR characteristic, so it is suitable for input capacitor use. It is recommended to use X5R or X7R MLCC capacitors in order to have better temperature performance and smaller capacitance tolerance. In order to suppress the output voltage ripple, the MLCC capacitor is also the best choice. The suggested part numbers of input / output capacitors are as follows:



Vendor	Part Number	Capacitance	Edc	Parameter	Size
TDK	C2012X5R1C106K	10uF	16V	X5R	0805
TDK	C3216X5R1E106K	10uF	25V	X5R	1206
TDK	C2012X5R0J226K	22uF	6.3V	X5R	0805
TDK	C3216X5R1A226M	22uF	10V	X5R	1206

### Output Inductor Selection

The output inductor selection mainly depends on the amount of ripple current through the inductor  $\Delta I_L$ . Large  $\Delta I_L$  will cause larger output voltage ripple and loss, but the user can use a smaller inductor to save cost and space. On the contrary, the larger inductance can get smaller  $\Delta I_L$  and thus the smaller output voltage ripple and loss. But it will increase the space and the cost. The inductor value can be calculated as:

$$L = \frac{V_{PWR} - V_{OUT}}{\Delta I_L \times F_{SW}} \times \frac{V_{OUT}}{V_{PWR}}$$

For most applications, 4.7uH to 10uH inductors are suitable for EA8212L. The suggested part numbers of output inductors are as follows:

Vendor	Part Number	Inductance	DCR (Max.)	Saturation Current	Dimensions (mm) (WxLxH)
SUMIDA	CDRH8D38-4R7	4.7uH	29mΩ	4A	8x8x3.8
SUMIDA	CDRH8D43R-6R8	6.8uH	29.8mΩ	4.2A	8.3x8.5x4.5

### PCB Layout Recommendations

For EA8212L PCB layout considerations, please refer to the following suggestions in order to get good performance.

- ▶ High current path traces (shown as Figure 5.) need to be widened.
- ▶ Place the input capacitors as close as possible to the PWR pin to reduce noise interference.
- ▶ Keep the feedback path (from  $V_{OUT}$  to FBK) away from the noise node (ex. SWITCH).
- ▶ SWITCH is a high current noise node. Complete the layout by using short and wide traces.

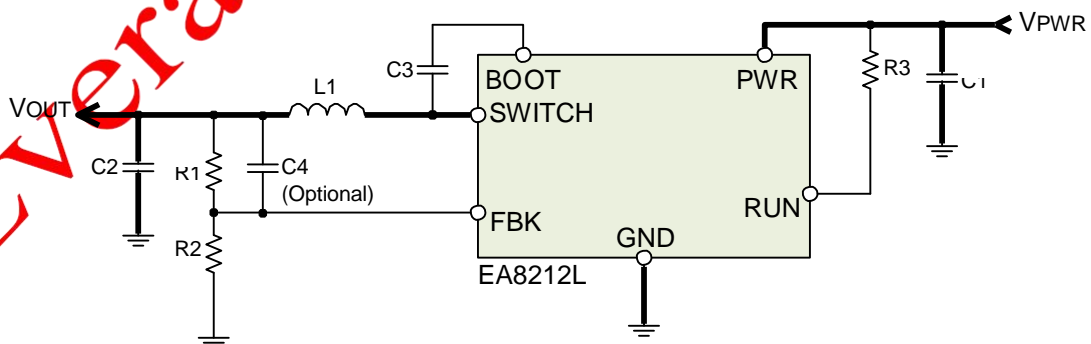

\* Bold lines indicate high current paths

Figure 5. Recommended high current traces layout guide



**Package Information**

SOT-23-6 Package

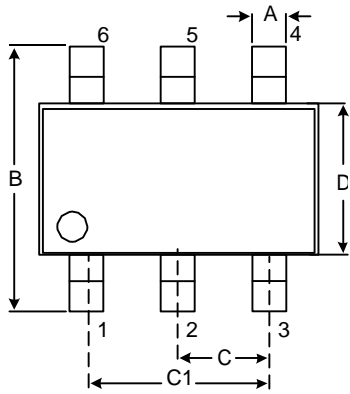

Top View

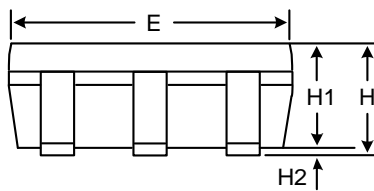

Side View

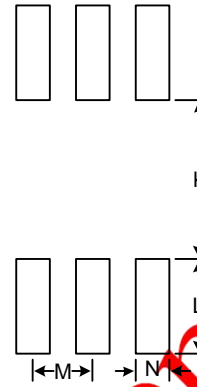

Recommended Layout Pattern

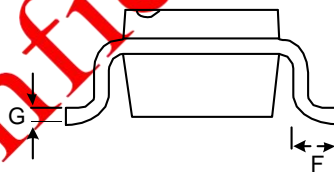

Front View

Unit: mm

Symbol	Dimension		Symbol	Dimension
	Min	Max		Typ
A	0.25	0.52	K	1.40
B	2.59	3.01	L	1.40
C	0.85	1.05	M	0.95
C1	1.70	2.10	N	0.65
D	1.40	1.80		
E	2.70	3.10		
F	0.30	0.62		
G	0.08	0.25		
H	0.89	1.35		
H1	0.89	1.20		
H2	0.00	0.15		