



Schottky Barrier Rectifiers
Reverse Voltage - 40 to 200 V
Forward Current - 30 A

ITO-220ABW

Features

- High current capability
- Low forward voltage drop
- Low power loss, high efficiency
- High surge capability
- High temperature soldering guaranteed
- Mounting position: any

Mechanical data

- Case: ITO-220ABW
- Approx Weight: 1.561g (0.055oz)
- Lead free finish, RoHS compliant
- Case Material: “Green” molding compound, UL flammability classification 94V-0, “Halogen-free”.

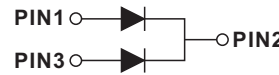
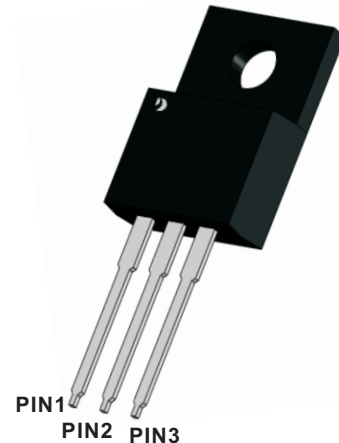

Maximum Ratings And Electrical Characteristics

Ratings At 25°C Ambient Temperature Unless Otherwise Specified

Characteristics	ITO-220	MBR3040FTS	MBR3045FTS	MBR3060FTS	MBR30100FTS	MBR30150FTS	MBR30200FTS	Units
Maximum Recurrent Peak Reverse Voltage	V_{RRM}	40	45	60	100	150	200	V
Maximum RMS voltage	V_{RMS}	28	32	42	70	105	140	V
Maximum DC Blocking Voltage	V_{DC}	40	45	60	100	150	200	V
Maximum Average Forward Rectified Current per leg per device	$I_{F(AV)}$	15 30						A
Peak Forward Surge Current, 8.3ms Single Half Sine-wave Superimposed on Rated Load (JEDEC method) per leg	I_{FSM}	200						A
Max Instantaneous Forward Voltage at 15A(per leg)	V_F	0.75		0.80	0.88	0.92	0.95	V
Maximum DC Reverse Current $T_J = 25^\circ\text{C}$ at Rated DC Reverse Voltage $T_J = 100^\circ\text{C}$	I_R	0.1 20			0.05 20			mA
Typical Thermal Resistance	$R_{\theta JA}$ $R_{\theta JC}$	45 8						$^\circ\text{C/W}$
Typical Junction Capacitance (f=1MHz, $V_R=4\text{V}$)	C_j	600			400			pF
Operating Junction Temperature Range	T_j	-55 ~ +150				-55 ~ +175		$^\circ\text{C}$
Storage Temperature Range	T_{stg}	-55 ~ +150				-55 ~ +175		$^\circ\text{C}$



Fig.1 Typical Forward Current Derating Curve

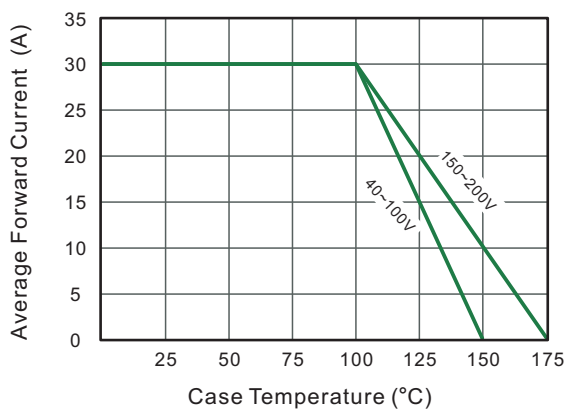

Fig.2 Typical Reverse Characteristics

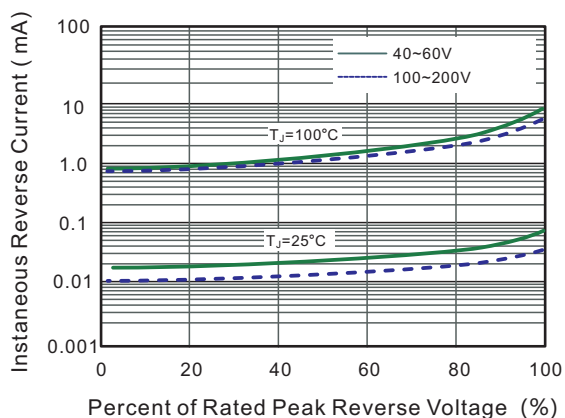

Fig.3 Typical Forward Characteristic(per leg)

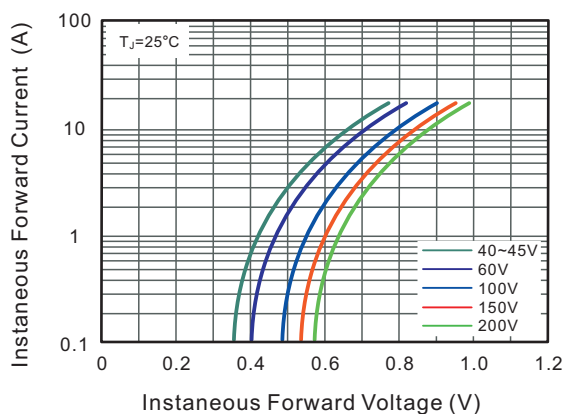

Fig.4 Typical Junction Capacitance

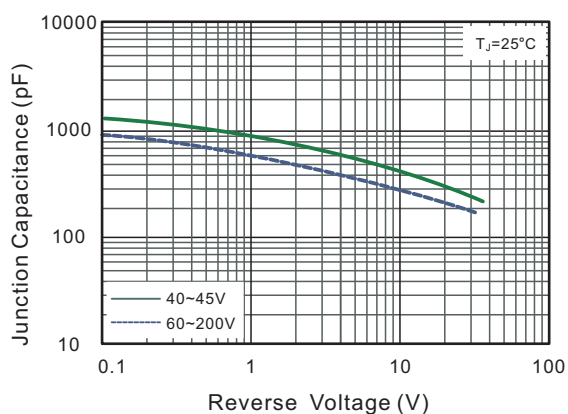

Fig.5 Maximum Non-Repetitive Peak Forward Surge Current

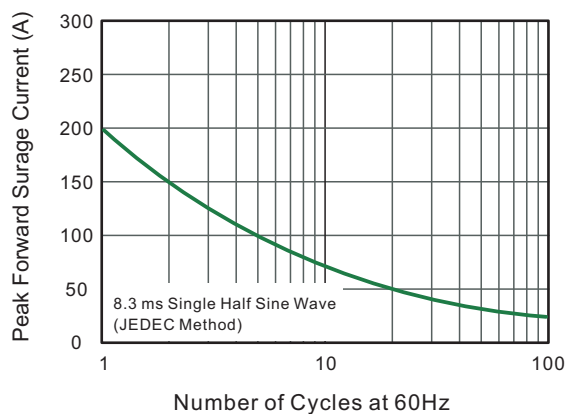
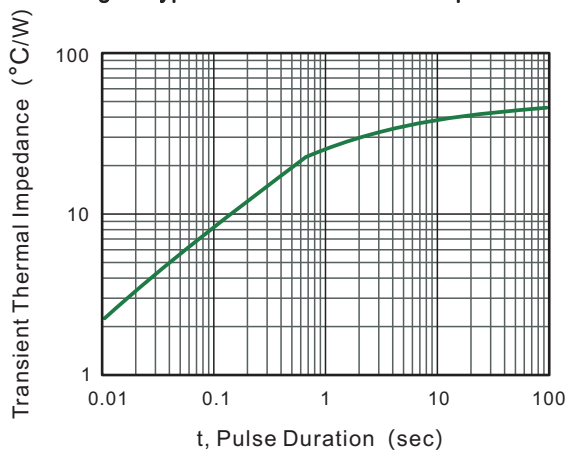

Fig.6- Typical Transient Thermal Impedance





Package Outline
Through Hole Package ; 3 leads

ITO-220ABW

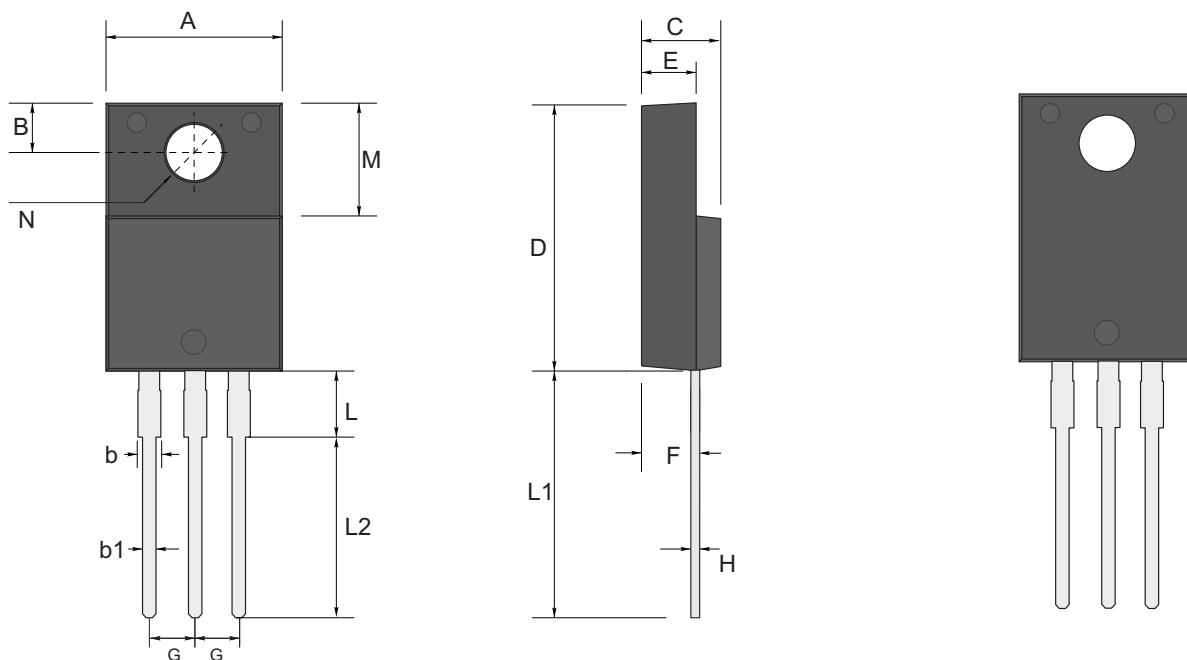

ITO-220ABW Mechanical data

UNIT		A	B	b	b1	C	D	E	F	G	H	L	L1	L2	M	N
mm	max	10.5	2.85	1.4	0.8	4.7	16.0	2.9	3.55	2.54 typ.	0.70	2.9	14.3	11.8	7.0	3.4 typ.
	typ	10.0	2.70	1.2	0.6	4.5	15.0	2.7	3.25		0.55	2.5	13.5	11.0	6.8	
	min	9.85	2.54	1.1	0.5	4.4	14.7	2.5	2.95		0.41	2.3	13.0	10.5	6.3	
mil	max	413	112	55	31	185	630	114	140	100 typ.	28	114	563	465	276	134 typ.
	typ	394	106	47	24	177	591	106	128		22	98	531	433	268	
	min	388	100	43	20	173	579	98	116		16	91	512	413	248	

Marking

Type number	Marking code
MBR3040FTS	MBR3040FTS
MBR3045FTS	MBR3045FTS
MBR3060FTS	MBR3060FTS
MBR30100FTS	MBR30100FTS
MBR30150FTS	MBR30150FTS
MBR30200FTS	MBR30200FTS



Important Notice and Disclaimer

Jingdao Microelectronics reserves the right to make changes to this document and its products and specifications at any without notice.

Customers should obtain and confirm the latest product information and specifications before final, purchase or use.

Jingdao Microelectronics makes no warranty, representation or guarantee regarding the suitability of its products for any particular purpose, not does Jingdao Microelectronics assume any liability for application assistance or customer product design.

Jingdao Microelectronics does not warrant or accept any liability with products which are purchased or used for any unintended or unauthorized application.

No license is granted by implication or otherwise under any intellectual property rights of Jingdao Microelectronics.

Jingdao Microelectronics products are not authorized for use as critical components in life support devices or systems without express written approval of Jingdao Microelectronics.