

5XG Series 5.0 x 3.2 mm SMD Crystal

5 : 5.0×3.2×1.4 mm | SMD5032-2P

X : Crystal Resonator

G : Glass Seal SMD Package

Feature

- AT-cut Crystal Construction
- Ceramic surface mount with glass sealed
- Package Size: 5.0 x 3.2 x 1.4mm (2PAD)
- Excellent heat resistance, high precision, and high reliability.
- Pb-free and RoHS/Green compliant

Applications

- Industrial applications
- Portable devices
- Short-range Wireless module
- Computers, Modems, Microprocessors



Electrical Specifications

Item	Symb.	Min.	Typ.	Max.	Unit	Notes
Frequency Range	Freq.	8.000		50.000	MHz	
Oscillation Mode		Fundamental (AT-cut)				
Frequency Tolerance	$\Delta f/f$			± 10	ppm	at 25°C±2°C
Operating Temperature	T_use	-20		70	°C	
		-40		85	°C	
Storage Temperature Range	T_sta	-55		125	°C	
Shunt Capacitance	C0			5	pF	
Drive Level	DL		10	300	μW	
Load Capacitance	CL	8		20	pF	
Insulation Resistance	IR			500	MΩ	at DC 100V
Aging	f_age			3	ppm	1st. Year at 25°C

Frequency Stability & Operating Temperature Range

Temp.	FT	±10ppm	±15ppm	±20ppm	±30ppm
	-20°C to +70°C		△	★	★
-40°C to +85°C			△	★	★

★: Available △: Conditional

Equivalent Series Resistance

Frequency Range	ESR(Max.)
8MHz ≤ Freq. < 10MHz	100 Ω
10MHz ≤ Freq. < 12MHz	80 Ω
12MHz ≤ Freq. < 16MHz	60 Ω
16MHz ≤ Freq. < 20MHz	50 Ω
20MHz ≤ Freq. < 24MHz	40 Ω
24MHz ≤ Freq. ≤ 50MHz	30 Ω

5XG Series 5.0 x 3.2 mm SMD Crystal

5 : 5.0×3.2×1.4 mm | SMD5032-2P

X : Crystal Resonator

G : Glass Seal SMD Package

Dimensions (UNIT:mm)

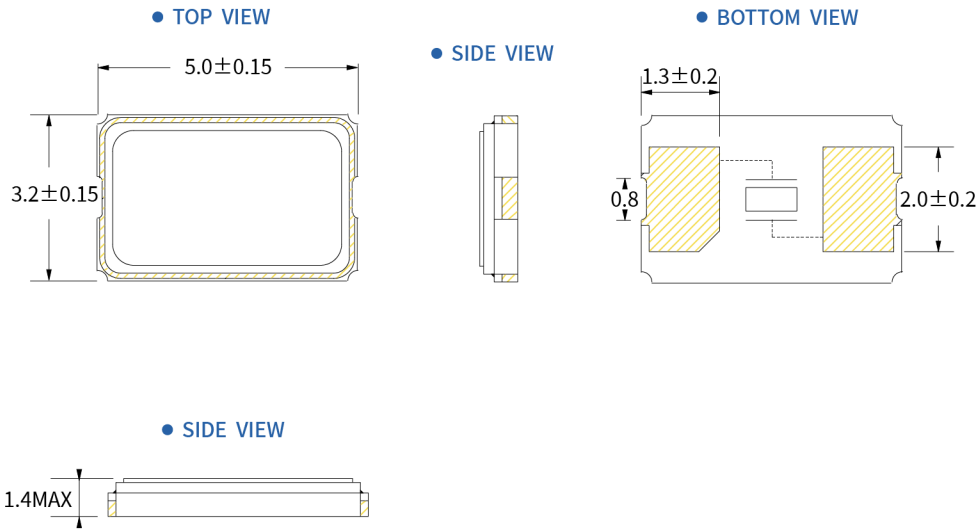

Solder pad layout (UNIT:mm)

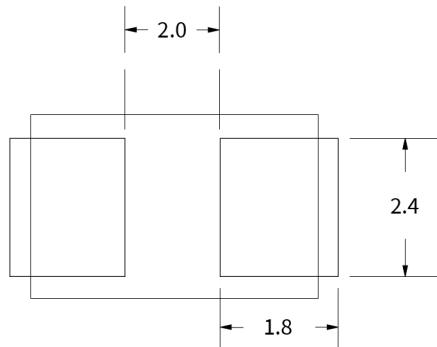

Options and Part Identification : Example SX5A8.000F1010F30G

Company	Ceramic Package	Frequency Code [MHz]	Vibration Mode	Load Capacitance	Frequency Tolerance	Operating Temperature	Frequency Drift	Material
SX	5A	X.XXX	F	10	10	F	30	G
Code Company	Code Ceramic Package	Frequency	Code Vibration Mode	Code Load Capacitance	Code Frequency Tolerance	Code Operating Temperature	Code Frequency Drift	Code Others
SX SCTF	5A 5.0 x 3.2 x 1.4mm[2PAD]	8.000	F AT - Fundamental	S Please specify CL in pF or S for series 08 8pF 10 10pF 12 12pF 20 20pF	10 ±10ppm 20 ±20ppm	E -20°C ~ +70°C F -40°C ~ +85°C	10 ±10ppm 15 ±15ppm 20 ±20ppm 30 ±30ppm	G Glass Seal SMD

If you have other parameter requirements, you can contact **SCTF** at any time.

5XG Series 5.0 x 3.2 mm SMD Crystal

5 : 5.0×3.2×1.4 mm | SMD5032-2P

X : Crystal Resonator

G : Glass Seal SMD Package

Frequency Temperature Characteristics

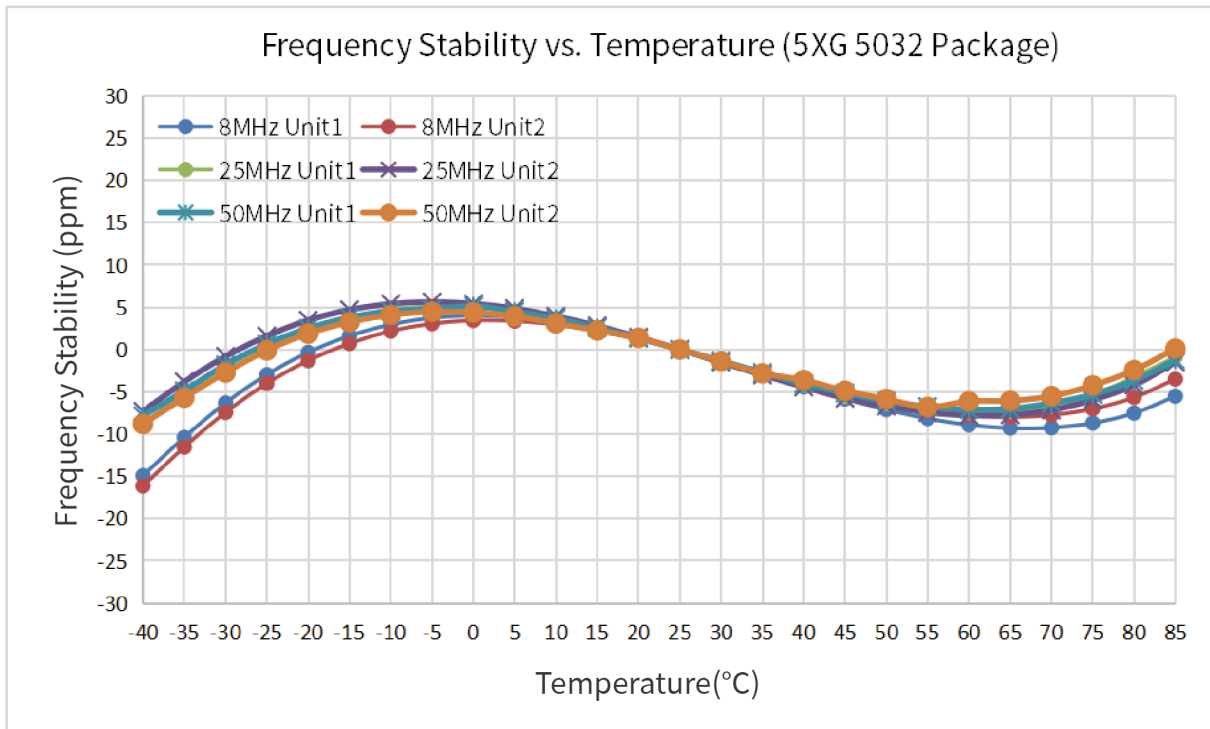

Product Structure & Marking Information

Product Structure

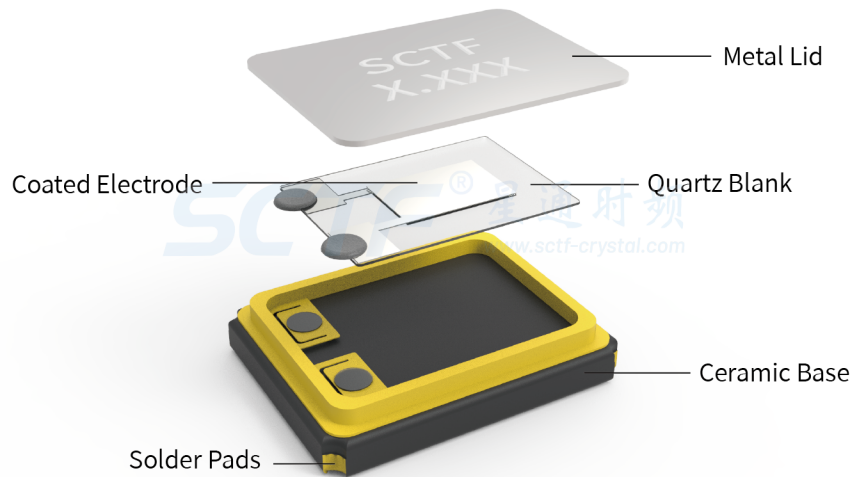

Marking Information

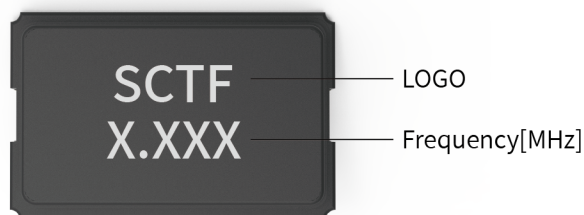

5XG Series 5.0 x 3.2 mm SMD Crystal

5 : 5.0×3.2×1.4 mm | SMD5032-2P

X : Crystal Resonator

G : Glass Seal SMD Package

Suggested Reflow Profile

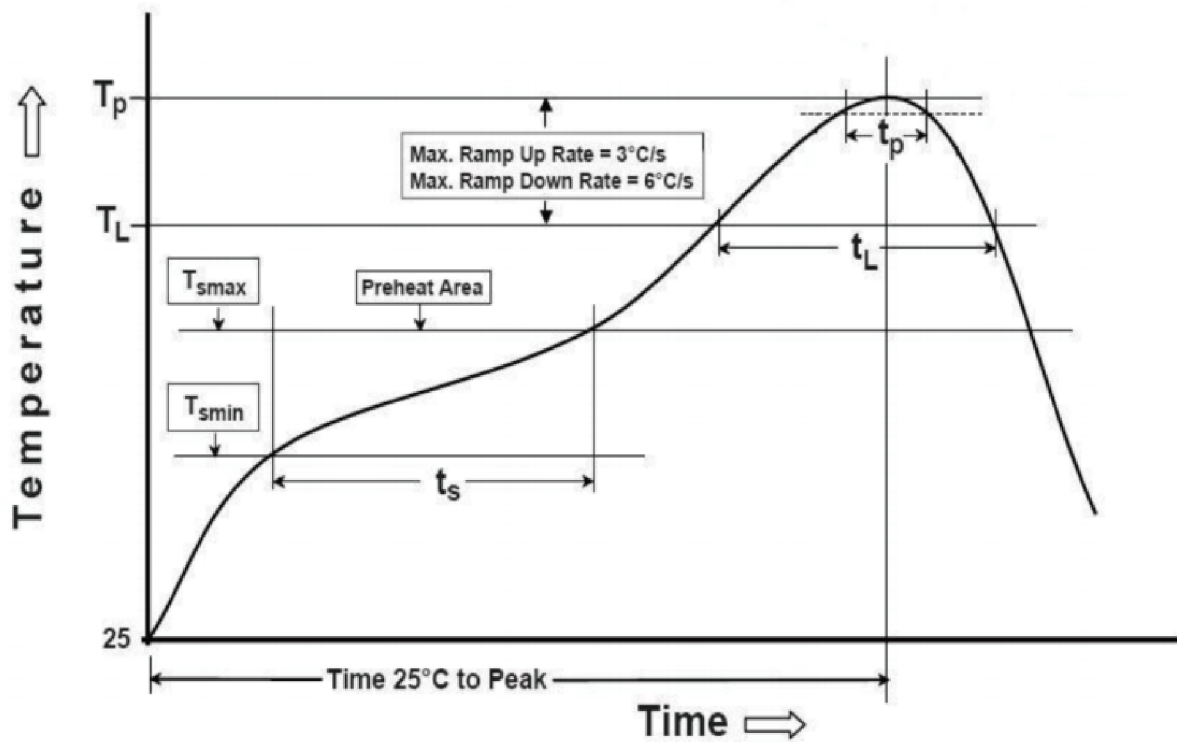

Profile Feature	Sn - Pb Eutectic Assembly	Preheat / Soak
Preheat / Soak <ul style="list-style-type: none"> ● Temperature Min (T_s min) ● Temperature Max (T_s max) ● Time (T_s min to T_s max) 	100°C 150°C 60-120 seconds	150°C 200°C 60-120 seconds
Ramp - up rate (T _L to T _p)	3°C/ second max.	3°C/ second max.
Time maintained above <ul style="list-style-type: none"> ● Liquidous temperature (T_L) ● Time (t_L) maintained above T_L 	183°C 60-150 seconds	217°C 60-150 seconds
Peak package body temperature (T _p)	235°C	260°C
Time within 5° C of the specified classification temperature (T _p)	20 seconds	30 seconds
Ramp - down rate (T _p to T _L)	6°C/ second max.	6°C/ second max.
Time 25° C to peak temperature	6 minutes max.	8 minutes max.
Suggest reflow times	2 Times max.	

5XG Series 5.0 x 3.2 mm SMD Crystal

5 : 5.0×3.2×1.4 mm | SMD5032-2P

X : Crystal Resonator

G : Glass Seal SMD Package

Packaging Information

T=Tape and reel (1,000pcs/reel)

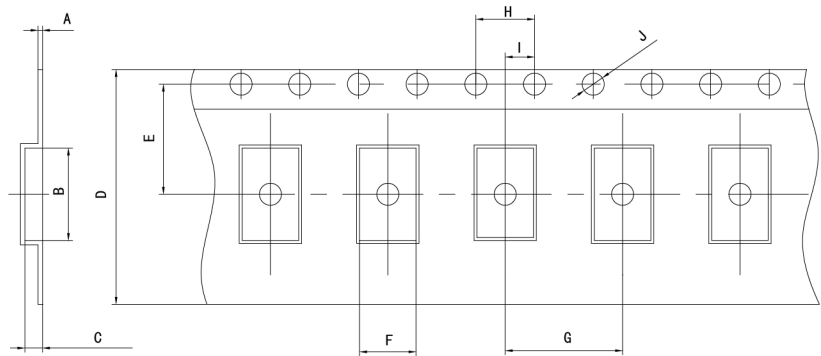
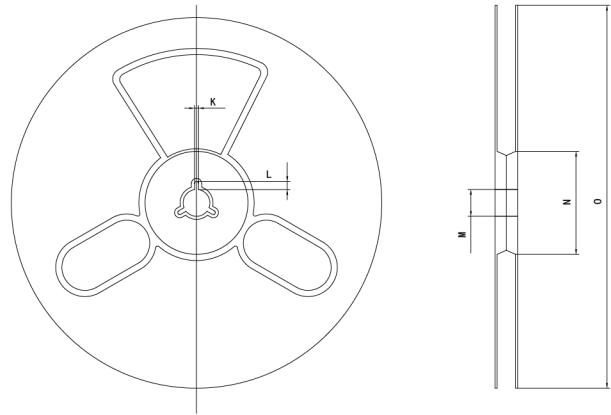

Pocket Tape Dimensions(mm)

Series	A	B	C	D	E	F	G	H	I	J	K	L	M	N	O
5XG	0.3±0.05	5.4±0.1	1.2±0.1	12±0.3	5.5±0.1	3.6±0.1	8.0±0.1	4.0±0.1	2.0±0.1	φ1.5±0.1	2.0±0.2	4.0±1.0	φ13±0.5	φ60±1	φ180±1

Common Frequencies – MHz

5XG Series				
8.000	8.192	10.000	11.0592	11.2896
12.000	12.288	13.000	13.560	14.31818
14.7456	16.000	16.384	18.432	19.6608
20.000	22.1184	24.000	24.576	25.000
26.000	27.000	27.120	28.63636	30.000
32.000	40.000	48.000	50.000	