

1. DESCRIPTION

These Schottky-clamped TTL MSI circuits are designed to be used in high-performance memory decoding or data-routing applications requiring very propagation delay times. In high-performance memory systems, these decoders can be used to minimize the effects of system decoding. When employed with high-speed memories utilizing a fast enable circuit, the delay times of the memory are usually less than the typical access time of the memory. This means that the effective system delay introduced by the Schottky-clamped system decoder is negligible.

The XL/XDLS138 decode one of eight lines dependent on the conditions at the three binary select inputs and the three binary select inputs reduce the need for external gates or inverters when expanding. A 24-line decoder can be implemented without external inverters and a 32-line decoder requires only one inverter. An enable input can be used as a data input for demultiplexing applications.

All of these decoder/demultiplexers feature fully buffered inputs, each of which represents only one normalized load to its driving circuit. All inputs are clamped with high-performance Schottky diodes to suppress line-ringing and to simplify system design.

The XL74LS138, XD74LS138 are characterized for operation from 0°C to 70°C.

2. PIN CONFIGURATIONS

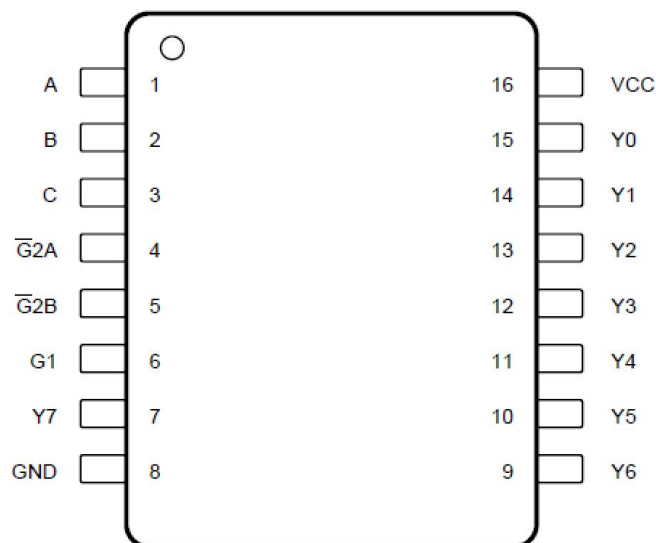

3. LOGIC DIAGRAM

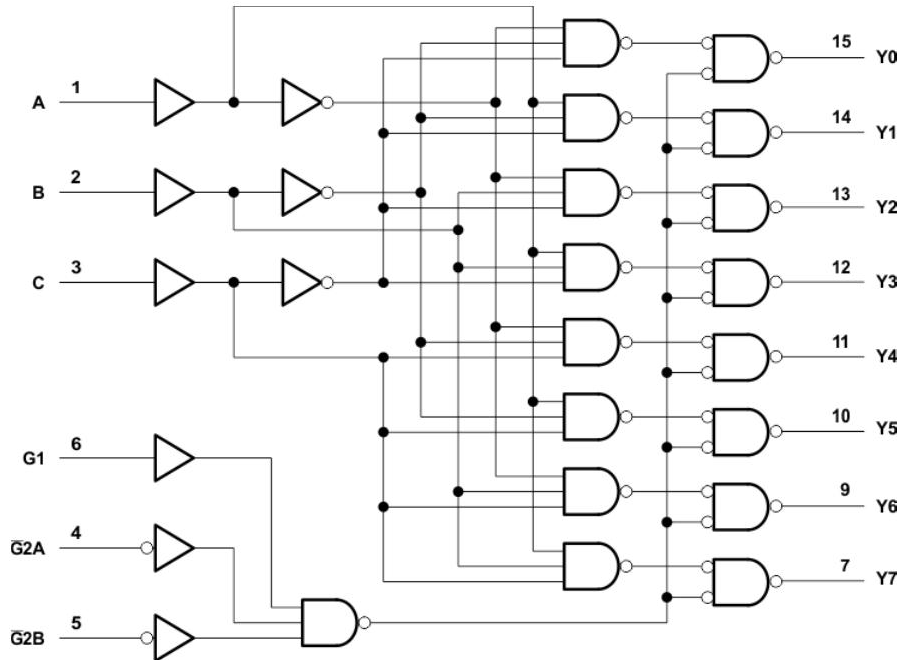

INPUTS					OUTPUTS							
ENABLE		SELECT										
$\overline{G1}$	$\overline{G2}^*$	C	B	A	Y0	Y1	Y2	Y3	Y4	Y5	Y6	Y7
X	H	X	X	X	H	H	H	H	H	H	H	H
L	X	X	X	X	H	H	H	H	H	H	H	H
H	L	L	L	L	L	H	H	H	H	H	H	H
H	L	L	L	H	H	L	H	H	H	H	H	H
H	L	L	H	L	H	H	L	H	H	H	H	H
H	L	L	H	H	H	H	H	L	H	H	H	H
H	L	H	L	L	H	H	H	H	L	H	H	H
H	L	H	L	H	H	H	H	H	H	L	H	H
H	L	H	H	L	H	H	H	H	H	H	L	H
H	L	H	H	H	H	H	H	H	H	H	H	L

4. SCHEMATICS OF INPUTS AND OUTPUTS

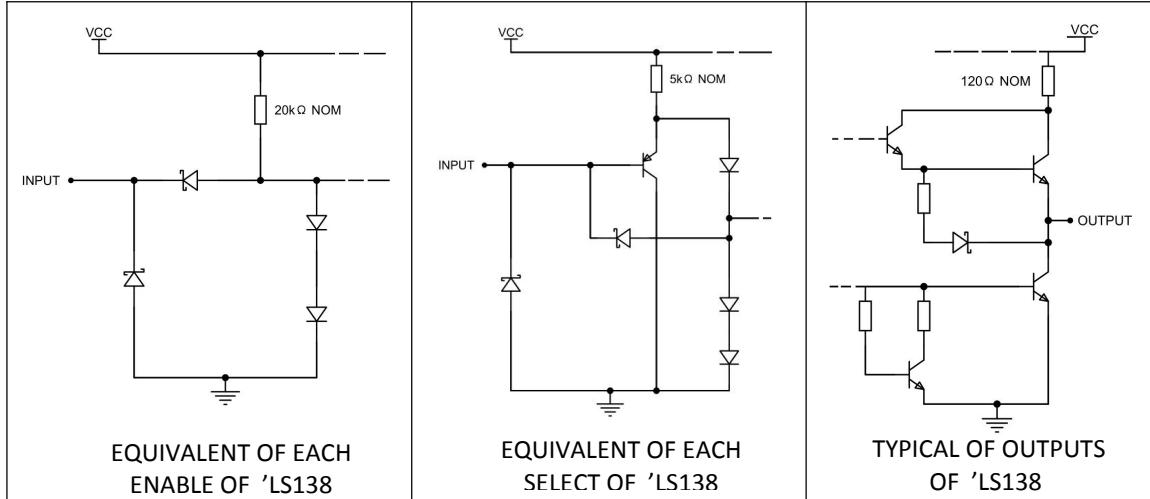

5. ABSOLUTE MAXIMUM RATINGS OVER OPERATING FREE-AIR TEMPERATURE RANGE (UNLESS OTHERWISE NOTES)

Supply voltage, V_{CC} (see Note 1).....	7V
Input voltage, V_I : 74LS138.....	7V
Operating free-air temperature range: SOP package.....	0°C to 70°C
DIP package.....	0°C to 70°C
Storage temperature range, T_{stg}	-65°C to 150°C

NOTE 1 : Voltlage values are with respect to network ground terminal.

6. RECOMMENDED OPERATING CONDITIONS

		XL/XD74LS138			UNIT
		MIN	NOM	MAX	
V _{CC}	Supply voltage	4.75	5	5.25	V
V _{IH}	High-level input voltage	2			V
V _{IL}	Low-level input voltage			0.8	V
I _{OH}	High-level output current			-0.4	mA
I _{OL}	Low-level output current			8	mA
T _A	Operating free-air temperature	0		70	°C

7. ELECTRICAL CHARACTERISTICS OVER RECOMMENDED OPERATING FREE-AIR RANGE (UNLESS OTHERWISE NOTED)

PARAMETER	TEST CONDITIONS [†]	XL/XD74LS138			UNIT
		MIN	TYP [‡]	MAX	
V _{IK}	V _{CC} = MIN, I _I = -18 mA			-1.5	V
V _{OH}	V _{CC} = MIN, V _{IL} = MAX, I _{OH} = -0.4 mA	2.7	3.4		V
V _{OL}	V _{CC} = MIN, V _{IH} = 2 V		0.25	0.4	V
			0.35	0.5	
I _I	V _{CC} = MAX, V _I = 7 V			0.1	mA
I _{IH}	V _{CC} = MAX, V _I = 2.7 V			20	μA
I _{IL}	V _{CC} = MAX, V _I = 0.4 V			-0.4	mA
I _{OS} [§]	V _{CC} = MAX			-0.2	mA
I _{CCH}	V _{CC} = MAX, V _I = 4.5 V	-20		-100	mA
I _{CCL}	V _{CC} = MAX, V _I = 0 V		6.3	10	mA

[†] For conditions shown as MIN or MAX, use the appropriate value specified under recommended operating conditions.

[‡] All typical values are at V_{CC} = 5 V, T_A = 25°C.

[§] Not more than one output should be shorted at a time, and the duration of the short-circuit should not exceed one second.

8. SWITCHING CHARACTERISTICS, V_{CC} = 5 V, T_A = 25°C

PARAMETER	FROM (INPUT)	TO (OUTPUT)	TEST CONDITIONS	XL/XD74LS138			UNIT
				MIN	TYP	MAX	
t _{PLH}	Binary Select	Any	R _L = 2 kΩ, CL = 15 pF See Note 2		11	20	ns
t _{PHL}					18	41	ns
t _{PLH}					21	27	ns
t _{PHL}					20	39	ns
t _{PLH}	Enable	Any			12	18	ns
t _{PHL}					20	32	ns
t _{PLH}					14	26	ns
t _{PHL}					13	38	ns

NOTE 2: Load circuits and voltage waveforms are shown in Section 1.

9. ORDERING INFORMATION

Ordering Information

Part Number	Device Marking	Package Type	Body size (mm)	Temperature (°C)	MSL	Transport Media	Package Quantity
XL74LS138	XL74LS138	SOP16	10.00 * 3.95	-0 to 70	MSL3	T&R	2500
XD74LS138	XD74LS138	DIP16	19.05 * 6.35	-0 to 70	MSL3	Tube 25	1000

10. DIMENSIONAL DRAWINGS

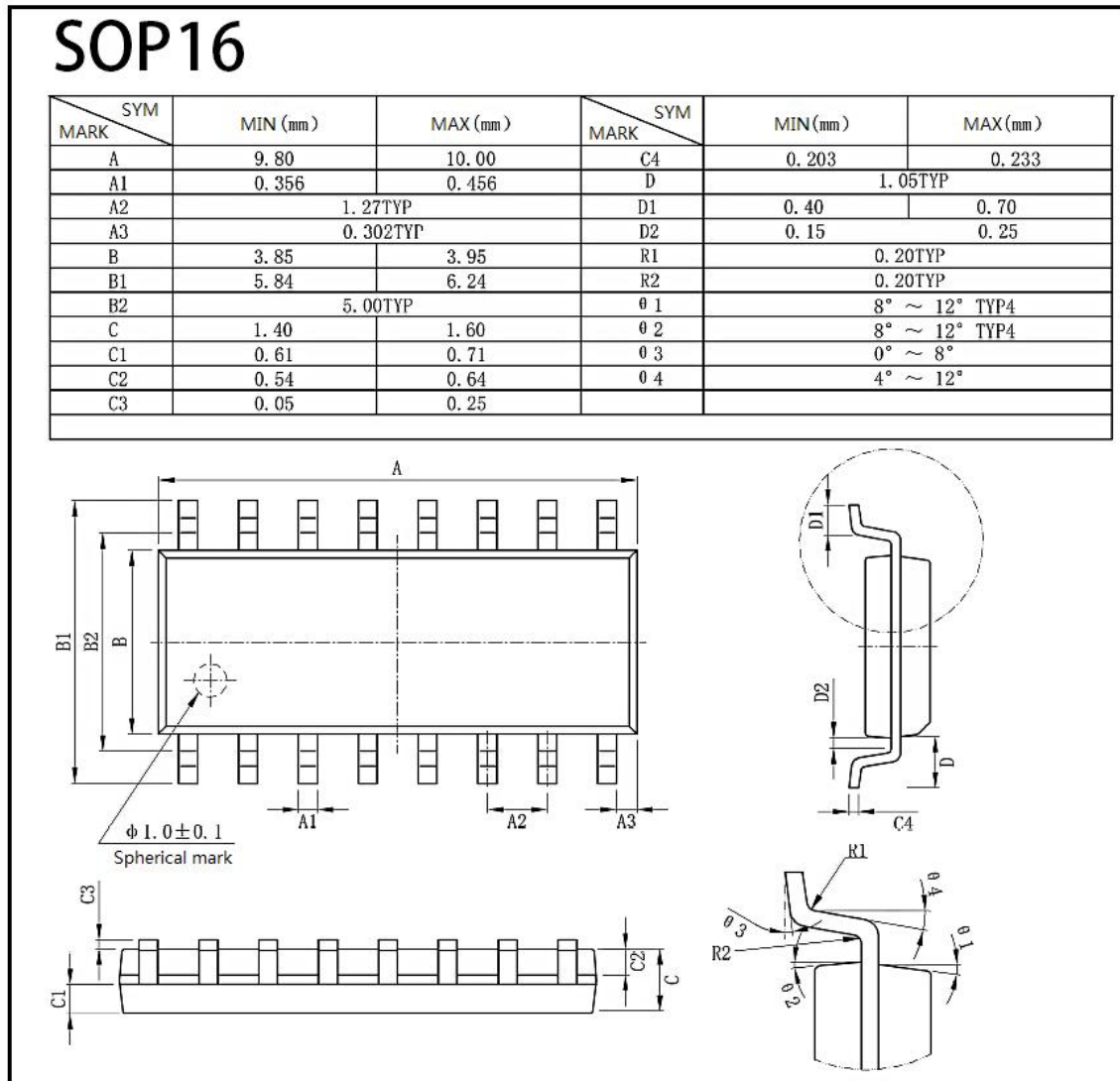

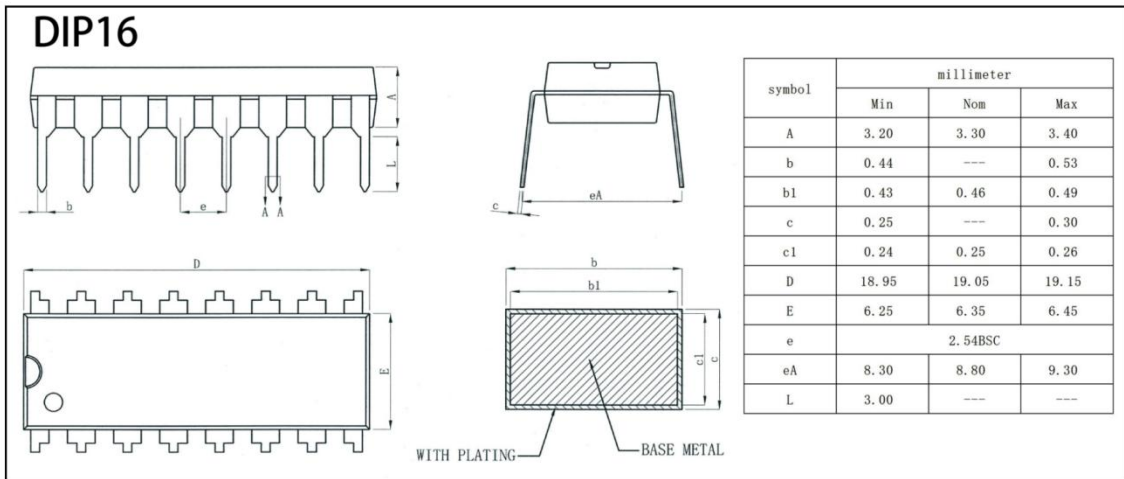

[if you need help contact us. Xinluda reserves the right to change the above information without prior notice]