

Specification of MEMS Microphone

RoHS Compliance & Halogen Free

LinkMems P/N: LMD4030T261-OY2S

Designed by	Checked by	Approved by
Kevin	Thomas	Hary

Customer Approval

Approved by: _____



Contents

1. Introduction	3
2. Electrical Characteristics	3
3. Timing Characteristics	4
4. Frequency Response Curve	5
5. Test Setup	5
6. Measurement Circuit	5
7. Mechanical Characteristics	6
7.1. Weight	6
7.2. Appearance Drawing	6
8. Application	7
8.1. Pickup Tool Pick Location & PCB Solder Pad Layout	7
8.2. Recommended Reflow Process Condition	7
8.3. Storage Condition	8
9. Packaging	8
9.1. Tape & Reel Specification	8
9.2. Packaging Information	9
10. Reliability Test	10

MEMS Microphone

1. Introduction

The LMD4030T MEMS Microphones are integrated with specialized Pre-amplification ASIC to provide high sensitivity, high SNR output from a capacitive audio sensor. It's packaged for surface mounting and high temperature reflow assembly. Data format is a single bit PDM.

2. Electrical Characteristics

Parameter	Absolute Maximum Rating	Unit
Voltage Range of VDD to Ground	-0.3 to +4.0	V
DATA, CLOCK, L/R to Ground	-0.3 to +4.0	V
Input Current	±5	mA
Temperature Range	-40 to +100	°C

Test Condition: 23±2°C, 55±20% R.H.VDD=2.0V.fclock=2.4MHz

Parameter	Symbol	Conditions	Min.	Typ.	Max.	Unit
Directivity			Omni-directional			
Sensitivity Range	S	94dB SPL @1kHz	-27	-26	-25	dB
Supply Voltage	VDD		1.6		3.6	V
Current Consumption	I	Supply Voltage			750	μA
S/N Ratio	SNR	94dB SPL @1kHz A-Weighted		64.5		dB(A)
Sleep Current	ISLEEP	F _{CLOCK} < 1kHz		3	4	μA
Total Harmonic Distortion	THD	94dB SPL @1kHz		0.2		%
Acoustic Overload Point	AOP	10% THD @1kHz		120		dB SPL
Power Supply Rejection	PSR	100mVpp Square wave@217Hz, A-weighted		-90		dBFS
Fall-asleep time		(F _{CLOCK} < 1kHz)			50	usec
Wake-up Time		F _{CLOCK} =2.4MHz			52	msec
Short Circuit Current	I _{SC}	Grounded Data Pin		1	10	mA
Output Load	C _{load}				100	pF

Parameter	Symbol	Conditions	Min.	Typ.	Max.	Unit
Data Format			1-Bit-PDM			
Clock Frequency	F_{CLOCK}		1.024	2.4	3.25	MHz
Clock Duty Cycle	F_{DC}		40		60	%
Clock Rise Time	T_{CR}				10	nsec
Clock Fall Time	T_{CF}				10	nsec
Logic Input High	V_{IH}		$0.75 \cdot V_{\text{DD}}$			V
Logic Input Low	V_{IL}				$0.25 \cdot V_{\text{DD}}$	V
Logic Output High	V_{OH}		$0.9 \cdot V_{\text{DD}}$			V
Logic Output Low	V_{OL}				$0.1 \cdot V_{\text{DD}}$	V
Delay Time for Valid Data	T_{DV}		18		40	nsec
Delay Time for High z	T_{DH}		0		15	nsec

3. Timing Characteristics

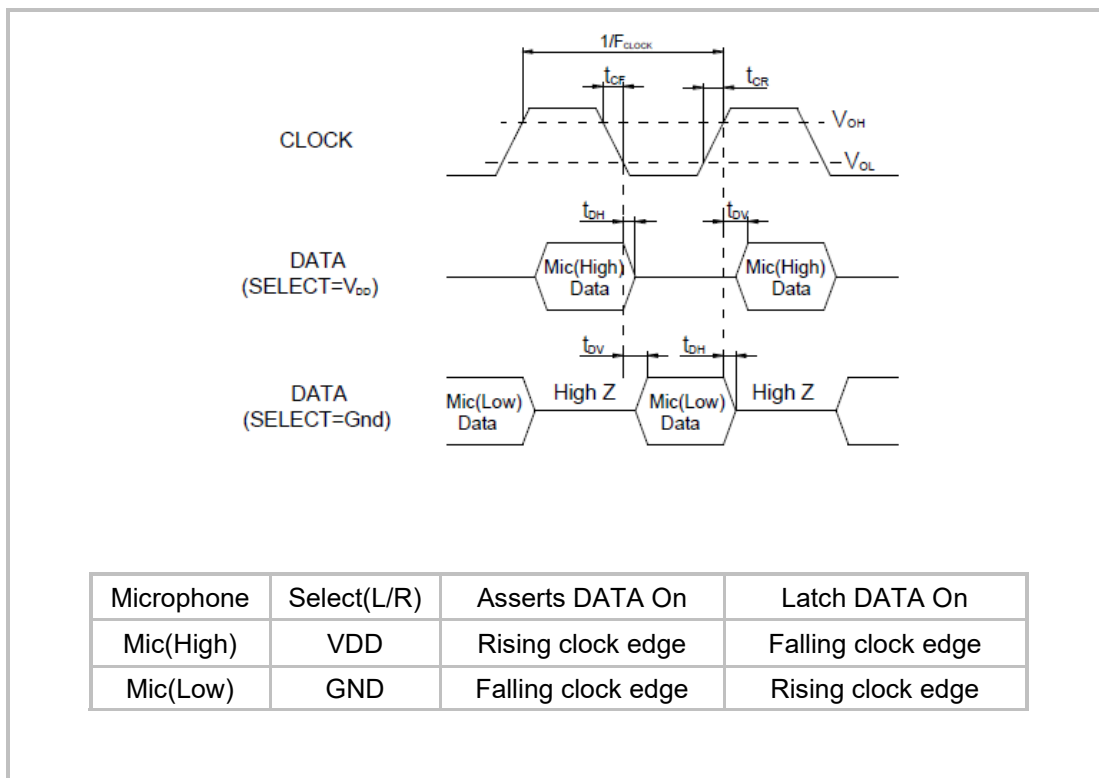

4. Frequency Response Curve

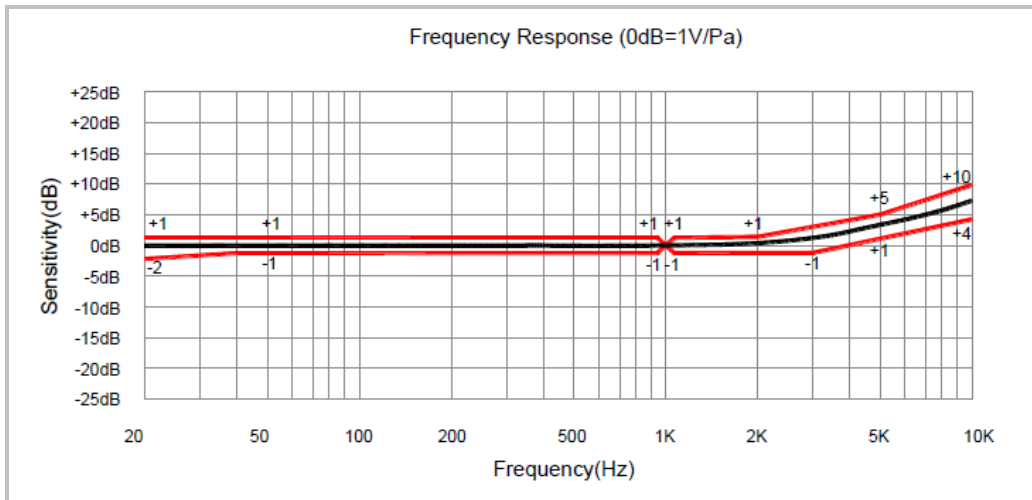

5. Test Setup (Sensitivity Test in Anechoic Room)

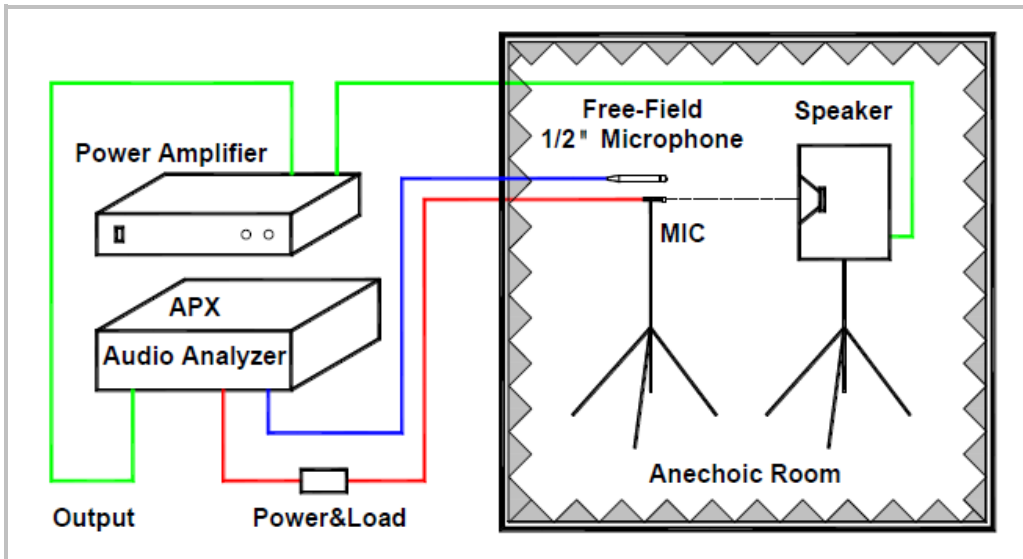

6. Measurement Circuit

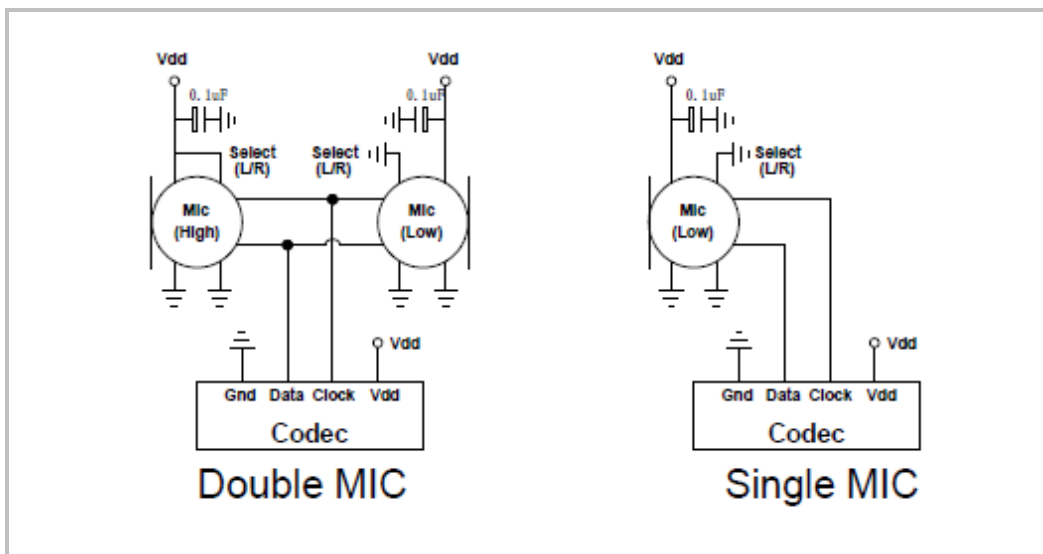

7. Mechanical Characteristics

7.1 Weight: Less than 0.03g

7.2 Appearance Drawing(unit: mm)

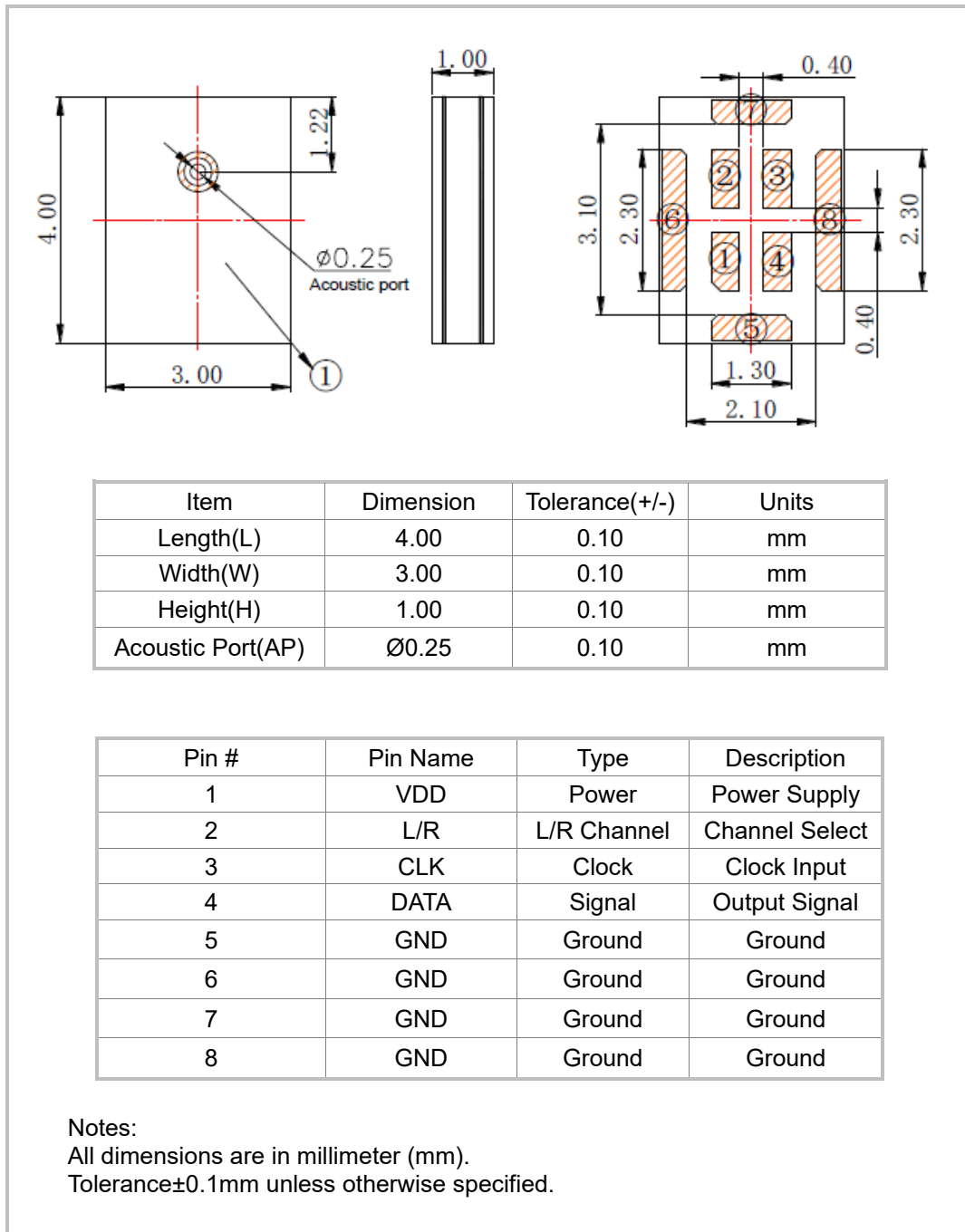

8. Application

8.1 Pickup Tool Pick Location & PCB Solder Pad Layout

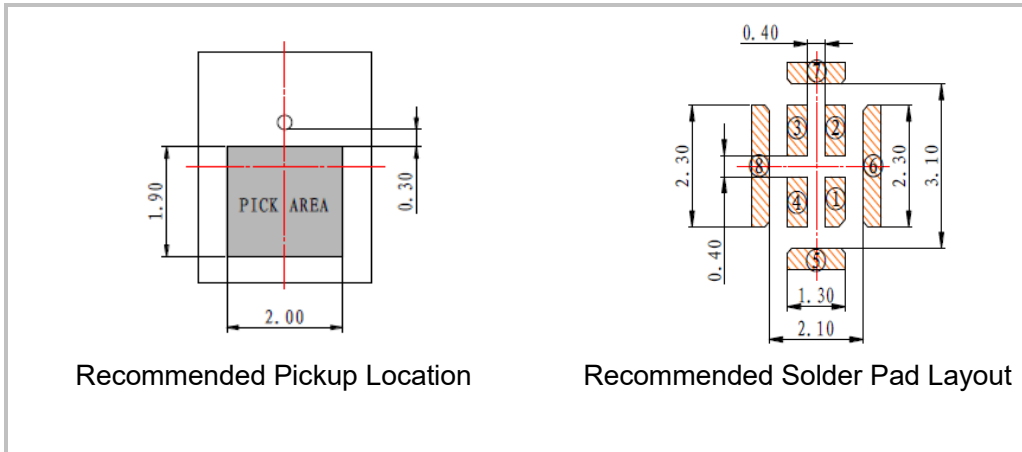

8.2 Recommended Reflow Process Condition

Recommend reflow profile, solder reflow $\leq 260^{\circ}\text{C}$ (for 30s Max of peak temperature).

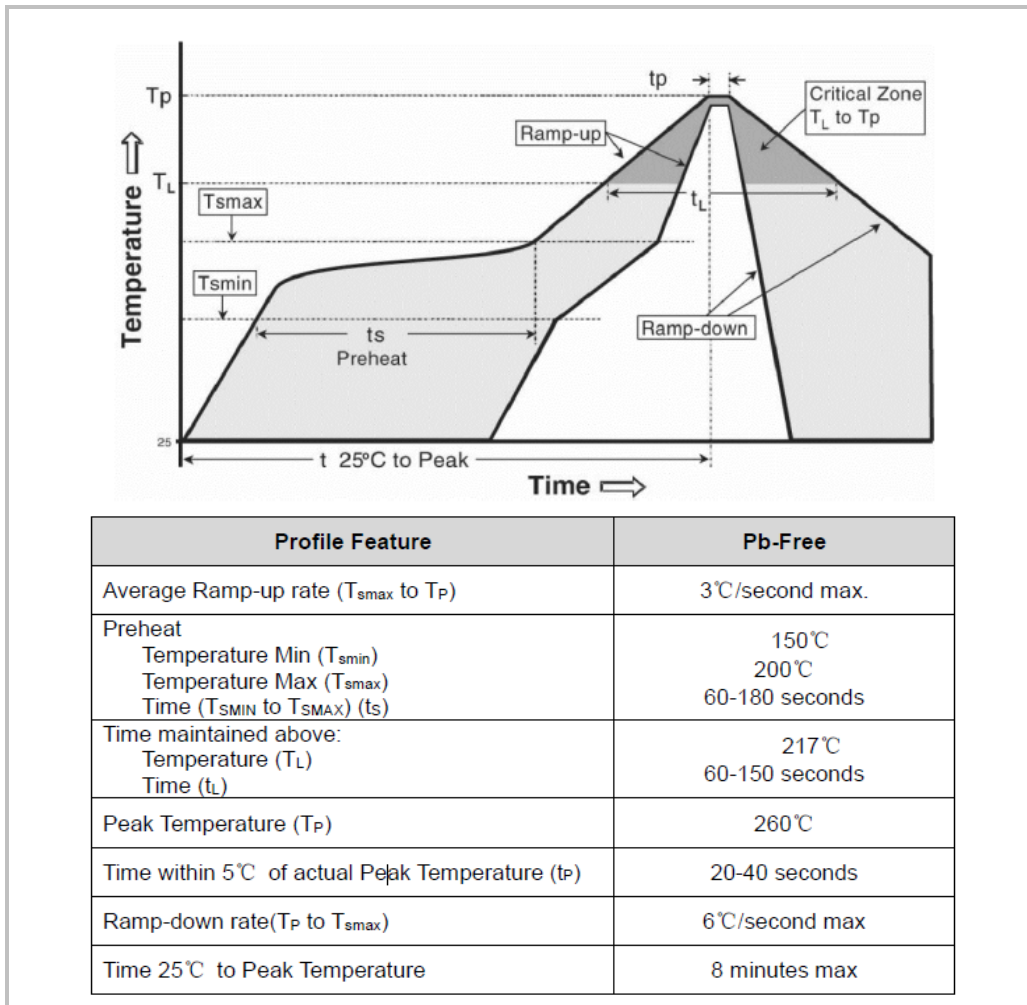

Important Notes

1. Pulling vacuum over acoustical hole of the microphone is not allowed, because the device can be damaged by vacuum.
2. Wash the board after reflow process is not allowed, because board washing and cleaning agents can damage the device. Device should not be exposed to ultrasonic processing or cleaning.
3. Recommended number of reflow is no more than 3 times.

8.3 Storage Condition

8.3.1 Storage temperature range:-40~+100℃,and humidity is less than 75%.

8.3.2 Operating temperature range:-40~+100℃.

8.3.3 MSL (moisture sensitivity Level) is Class 1.

9. Packaging

9.1 Tape & Reel Specification

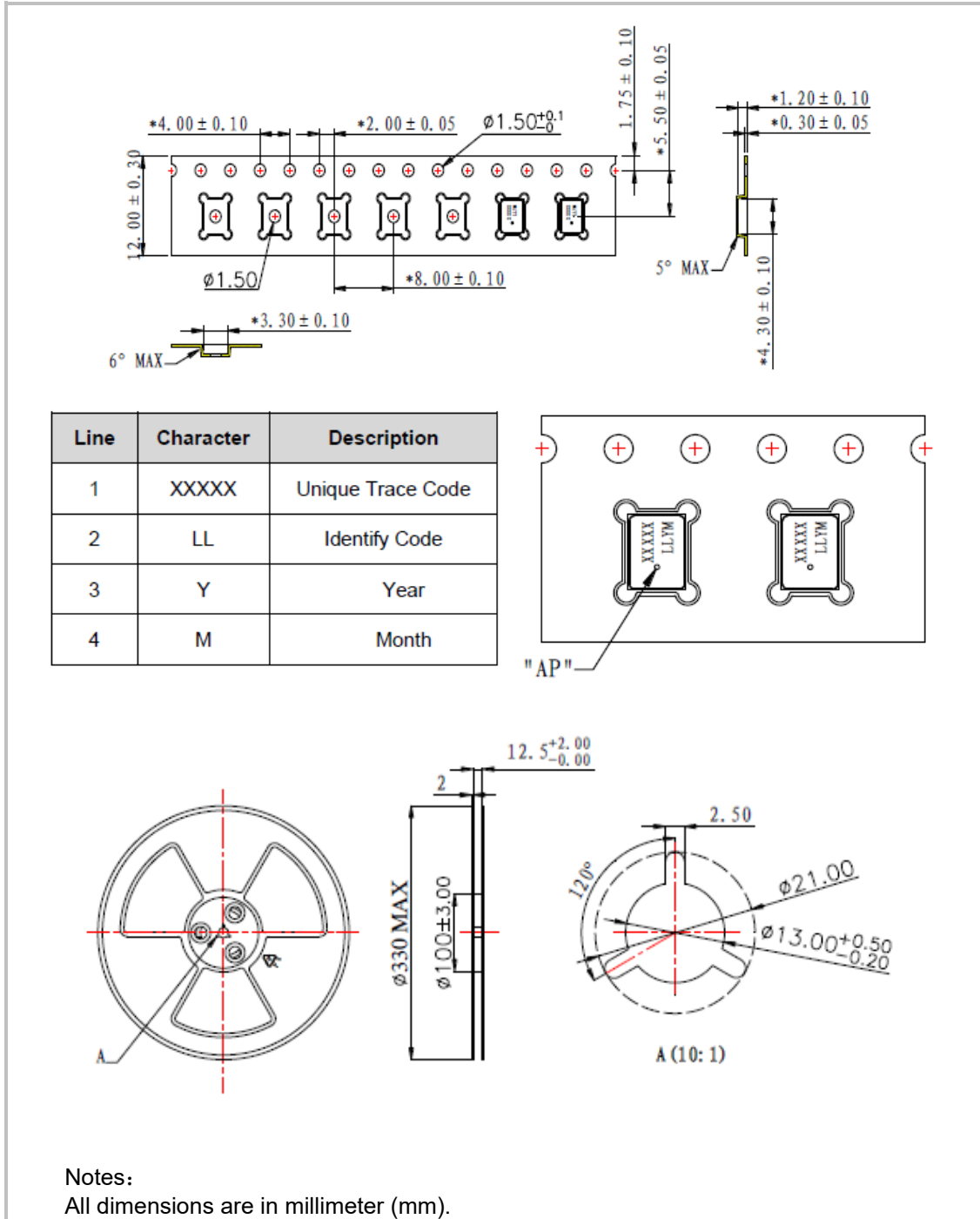

9.2 Packaging Information

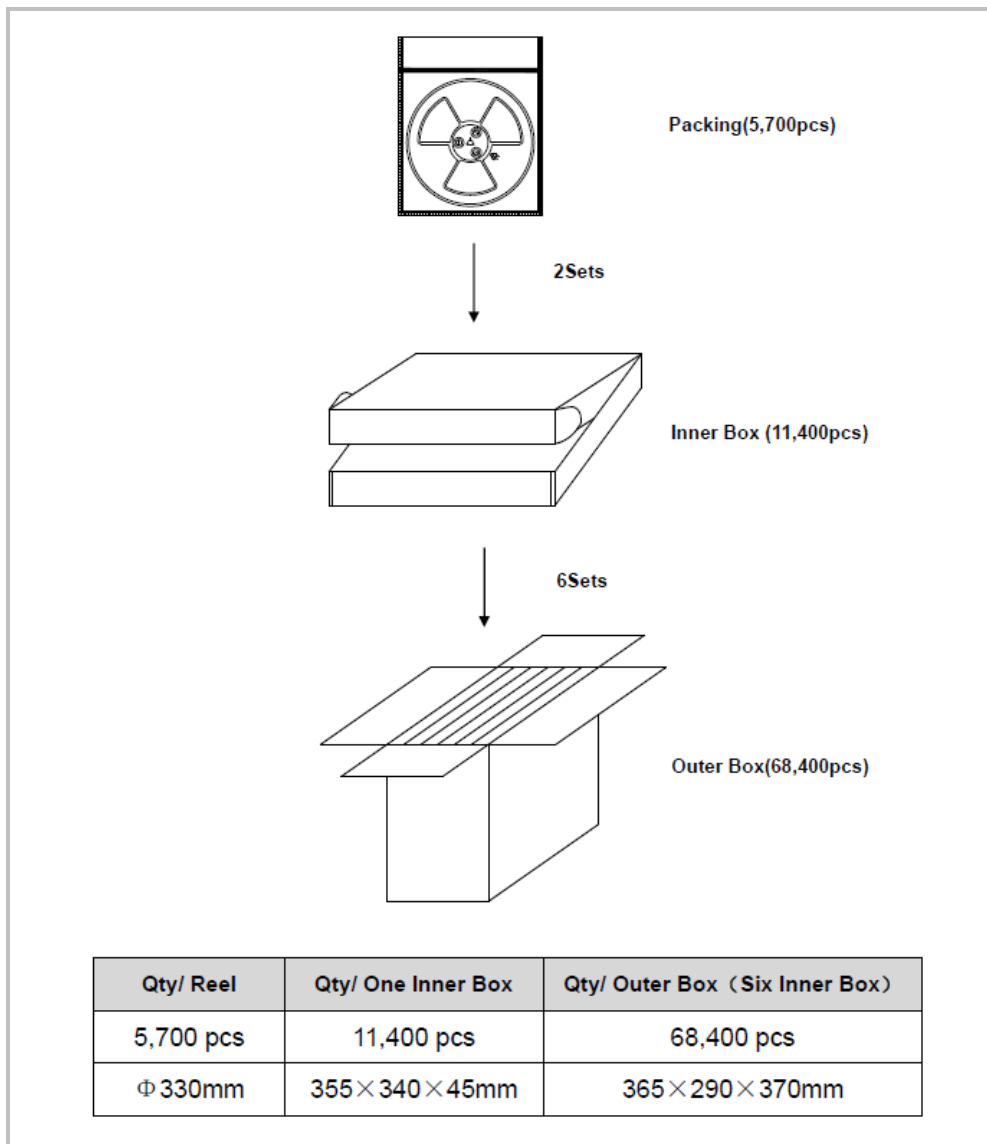

10. Reliability Test

The samples should be placed in the room with 23+/-2°C, 55+/-10%R.H. for 2 hours at least before final measurement, unless otherwise specified.

Item	Detail	Standard
Thermal Shock	100 cycles of air-air thermal shock from -40°C to +105°C with 15 minute soaks.	±3 dB
High Temperature Storage	+105°C environment for 240 hours.	±3 dB
Low Temperature Storage	-40°C environment for 240 hours.	±3 dB
High Temperature Test	+105°C environment while under bias for 240 hours.	±3 dB
Low Temperature Test	-40°C environment while under bias for 240 hours.	±3 dB
Humidity Test	+85°C/85% R.H. environment while under bias for 240 hours.	±3 dB
Vibration Test	16 minutes in each X, Y, Z axis from 20 to 2,000 Hz with peak acceleration of 20G.	±3 dB
Drop Test	1.5-meter height onto a concrete surface each time at three directions in state of packaging.	±3 dB
Reflow Test	5 reflow cycles with peak temperature of +260°C.	±3 dB
ESD Test	Under C=150pF, R=330ohm. Tested to ±8KV contact to the case and tested to ±2kV contact to I/O terminals. 10 times. Grounding.	±3 dB

Specification Revisions

Revision	Description	Approved	Date
1.1	New Version Released	Hary	17/05/2024