

Specification of MEMS Microphone

RoHS Compliance & Halogen Free

LinkMems P/N: LMD4020T261-OC3

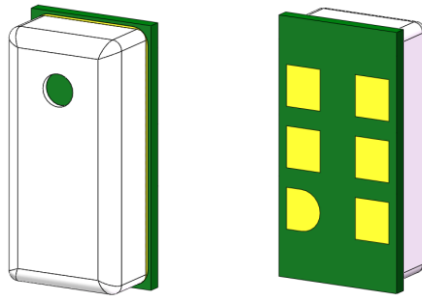

| Designed by | Checked by | Approved by |
|-------------|------------|-------------|
| Kevin | Thomas | Hary |

Customer Approval

Approved by: _____



Contents

| | |
|--|----|
| 1. Introduction | 3 |
| 2. Electrical Characteristics | 3 |
| 3. Timing Characteristics | 5 |
| 4. Frequency Response Curve | 5 |
| 5. Test Setup | 6 |
| 6. Measurement Circuit | 6 |
| 7. Mechanical Characteristics | 7 |
| 7.1. Weight | 7 |
| 7.2. Appearance Drawing | 7 |
| 8. Application | 8 |
| 8.1. Pickup Tool Pick Location & PCB Solder Pad Layout | 8 |
| 8.2. Recommended Reflow Process Condition | 8 |
| 8.3. Storage Condition | 8 |
| 9. Packaging | 9 |
| 9.1. Tape & Reel Specification | 9 |
| 9.2. Packaging Information | 10 |
| 10. Reliability Test | 11 |

MEMS Microphone

1. Introduction

The LMD4737T MEMS Microphones are integrated with specialized Pre-amplification ASIC to provide high sensitivity, high SNR output from a capacitive audio sensor. It's packaged for surface mounting and high temperature reflow assembly. Data format is a single bit PDM.

2. Electrical Characteristics

Test Condition: $V_{DD}=1.8V$, $23\pm 2^{\circ}C$, $55\pm 10\%R.H.$, unless otherwise specified.

Electrical Characteristics

| Parameter | Symbol | Note/Test Condition | Values | | | Unit |
|----------------------|----------|---------------------|--------|------|------|------|
| | | | Min. | Typ. | Max. | |
| Power supply voltage | V_{DD} | | 1.62 | 1.8 | 3.6 | V |

Standard Mode

Test Condition: Measurement Clock Frequency 2.4 MHz, $V_{DD} = 1.8 V$

| Specification | Symbol | Test Conditions | Min. | Typ. | Max. | Unit |
|---------------------------|--------|--|------------------|------|------|---------|
| Directivity | | | Omni-directional | | | |
| Sensitivity Range | S | 94dB SPL @1kHz | -27 | -26 | -25 | dB |
| Current Consumption | I | | | 750 | | μA |
| S/N Ratio | SNR | 94dB SPL @1kHz A-Weighted | | 64 | | dB(A) |
| Total Harmonic Distortion | THD | 94dB SPL @1kHz | | | 0.5 | % |
| Acoustic Overload Point | AOP | 10% THD @1kHz | | 120 | | dB SPL |
| Power Supply Rejection | PSR | 100mVpp Square wave@217Hz, A-weighted | | -80 | | dB |

Low Power Mode

Test Condition: Measurement Clock Frequency 768 kHz, VDD = 1.8 V

| Specification | Symbol | Test Conditions | Min. | Typ. | Max. | Unit |
|---------------------------|--------|--|------------------|------|------|--------|
| Directivity | | | Omni-directional | | | |
| Sensitivity Range | S | 94dB SPL @1kHz | -27 | -26 | -25 | dB |
| Current Consumption | I | | | 320 | | μA |
| S/N Ratio | SNR | 94dB SPL @1kHz A-Weighted | | 63 | | dB(A) |
| Total Harmonic Distortion | THD | 94dB SPL @1kHz | | | 0.5 | % |
| Acoustic Overload Point | AOP | 10% THD @1kHz | | 120 | | dB SPL |
| Power Supply Rejection | PSR | 100mVpp Square wave@217Hz, A-weighted | | -80 | | dB |

Operation Ratings

| Parameter | Symbol | Note/Test Condition | Vales | | | Unit |
|----------------------|-----------------|---------------------|-----------------------|------|----------------------|------|
| | | | Min | Typ. | Max | |
| Power supply voltage | V _{DD} | | 1.62 | | 3.6 | V |
| Frequency Range | Sleep Mode | | 0 | | 50 | kHz |
| | Low Power Mode | | 150 | 768 | 900 | kHz |
| | Standard Mode | | 1000 | | 4800 | kHz |
| Duty Cycle | DC | | 45 | 50 | 55 | % |
| Logic Input High | | | 0.65*V _{DD} | | V _{DD} +0.3 | V |
| Logic Input Low | | | -0.3 | | 0.35*V _{DD} | V |
| Logic Output High | | | V _{DD} -0.45 | | | V |
| Logic Output Low | | | | | 0.45 | V |
| Load Capacitance | | | | | 140 | pF |

3. Timing Characteristics

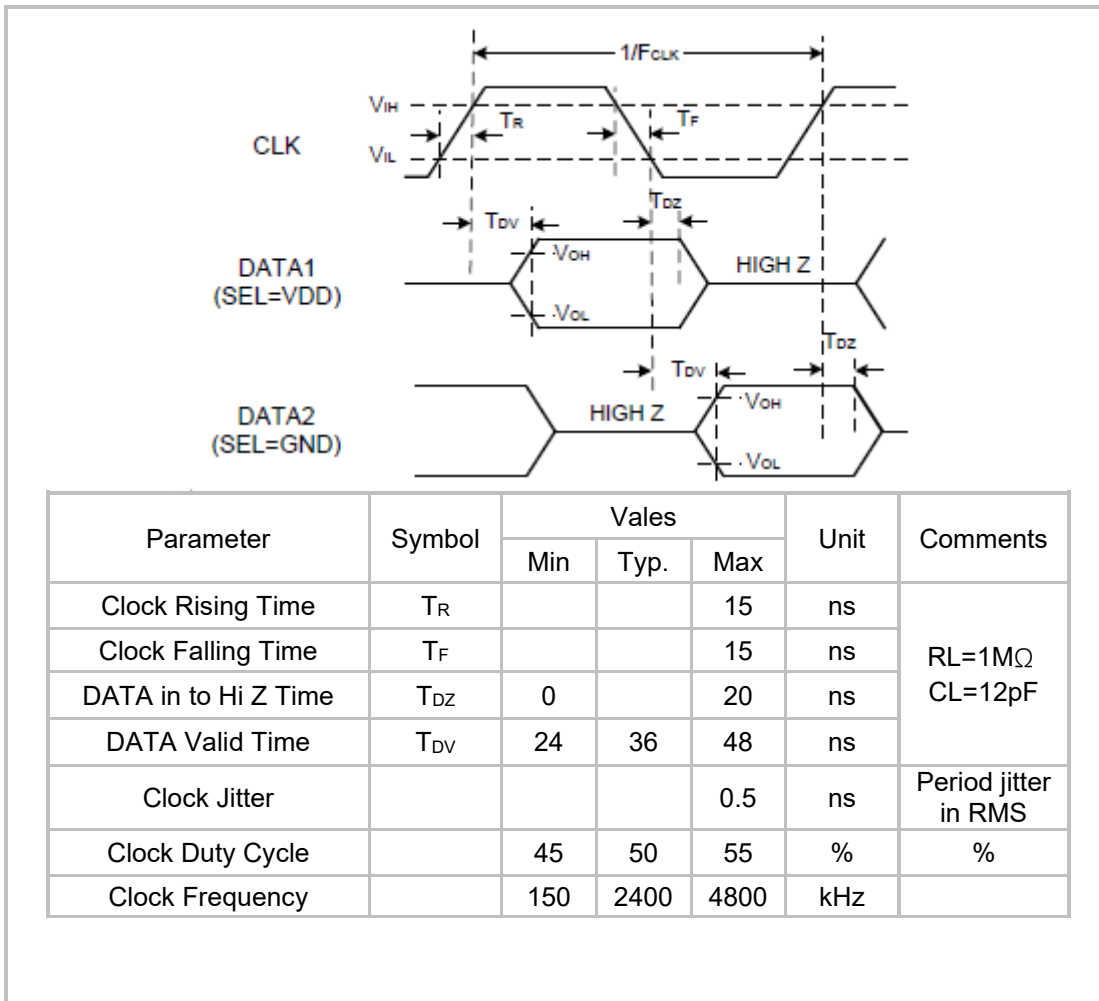

4. Frequency Response Curve

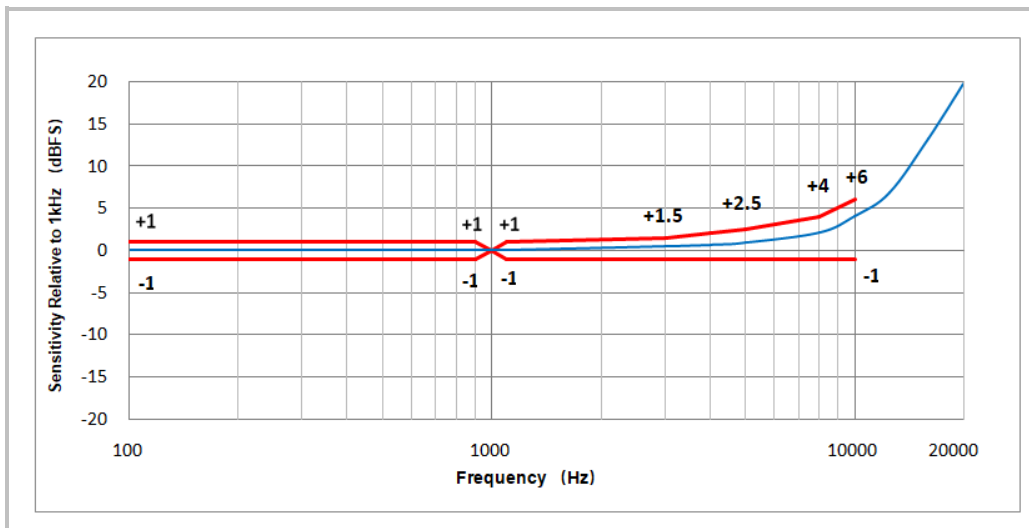

5. Test Setup (Sensitivity Test in Anechoic Room)

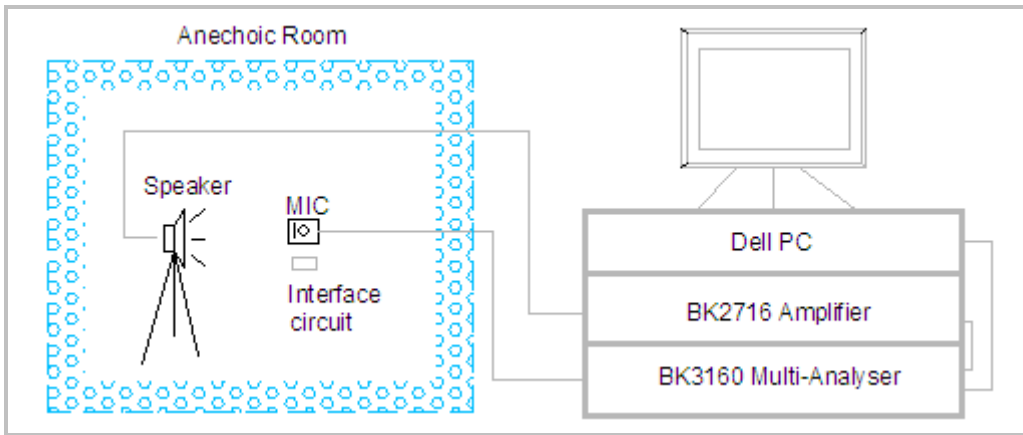

6. Measurement Circuit

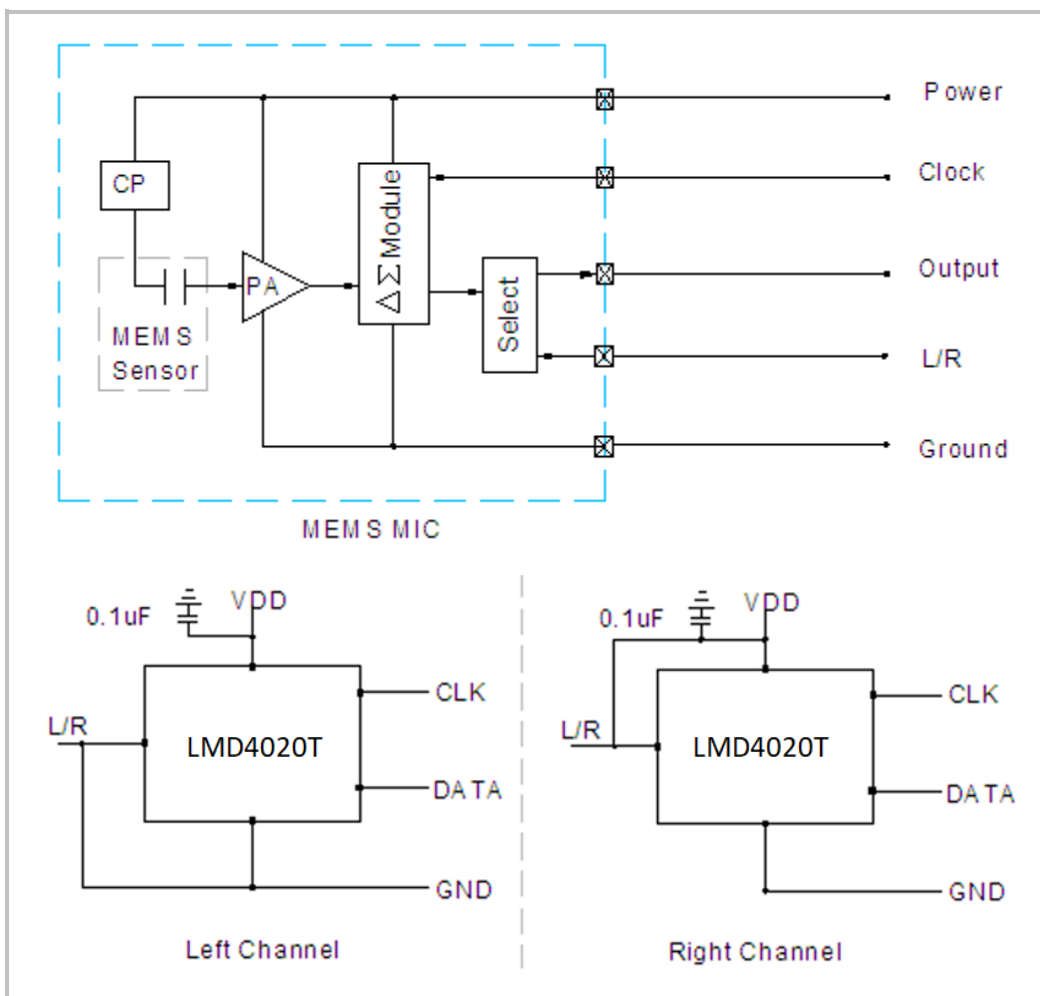

7. Mechanical Characteristics

7.1 Weight: Less than 0.05g

7.2 Appearance Drawing (unit: mm)

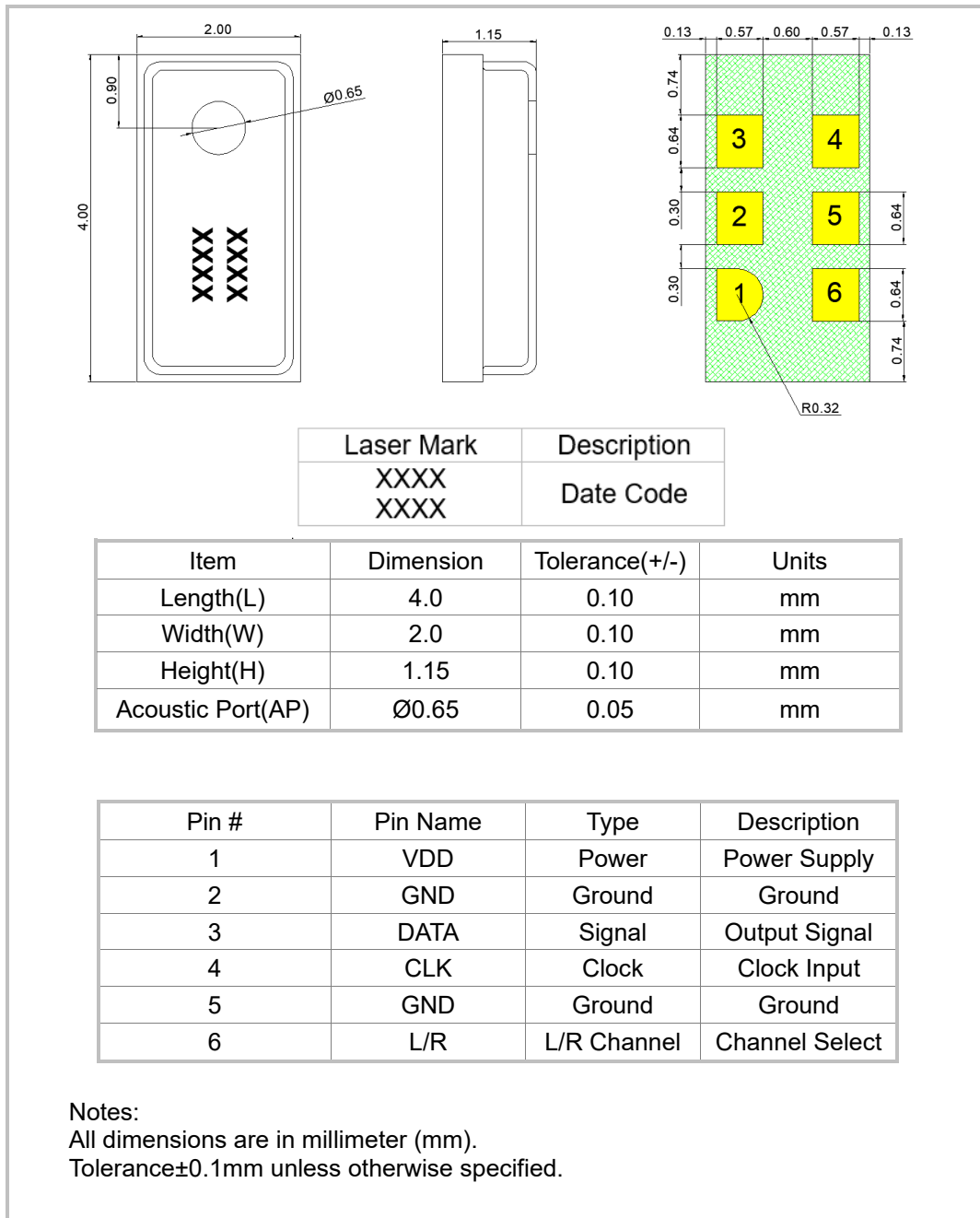

8. Application

8.1 Pickup Tool Pick Location & PCB Solder Pad Layout

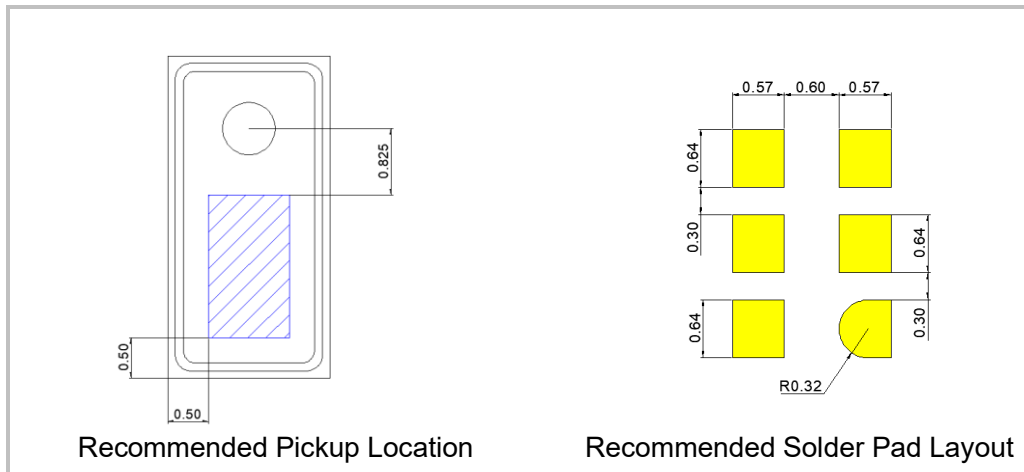

8.2 Recommended Reflow Process Condition

Recommend reflow profile, solder reflow $\leq 260^{\circ}\text{C}$ (for 30s Max of peak temperature).

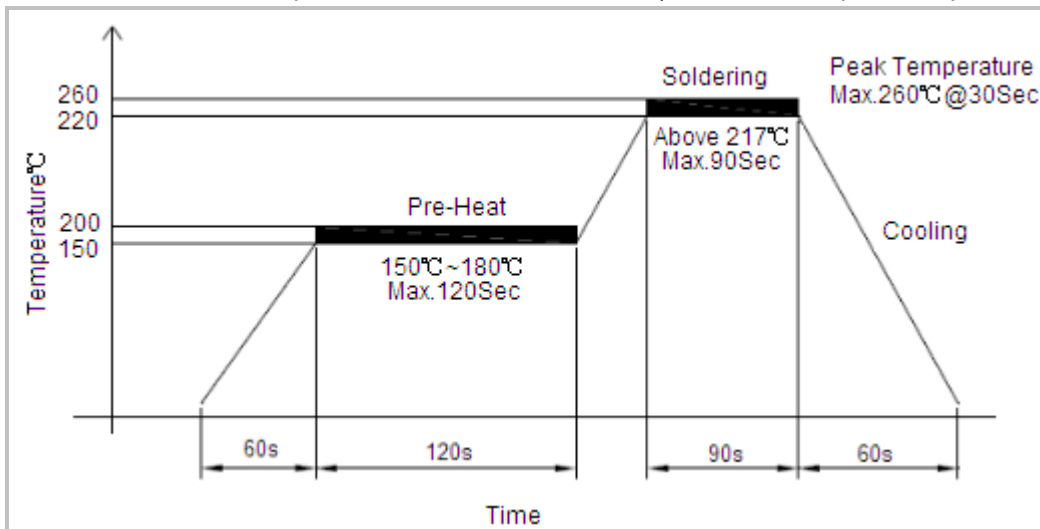

Important Notes

In order to minimize device damage:

1. Do not wash or clean the boards after the reflow process.
2. Do not apply the airflow which pressure over 0.3MPa blow into the port hole within a distance of less than 5 cm.
3. Do not exposed to ultrasonic processing or cleaning.
4. Do not pull a vacuum over port hole of the microphone.

8.3 Storage Condition

8.3.1 Storage temperature range:-40~+100 $^{\circ}\text{C}$, and humidity is less than 75%.

8.3.2 Operating temperature range:-40~+85 $^{\circ}\text{C}$.

8.3.3 MSL (moisture sensitivity Level) is Class 1.

9. Packaging

9.1 Tape & Reel Specification

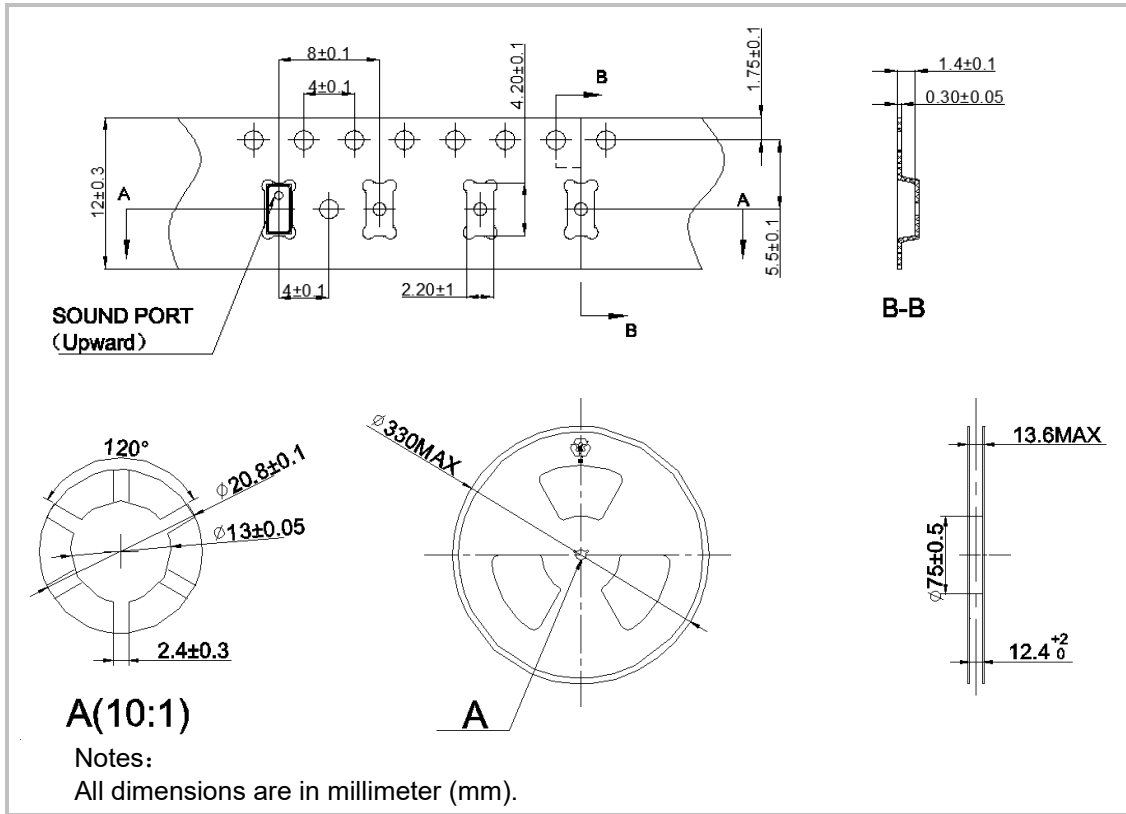

9.2 Packaging Information

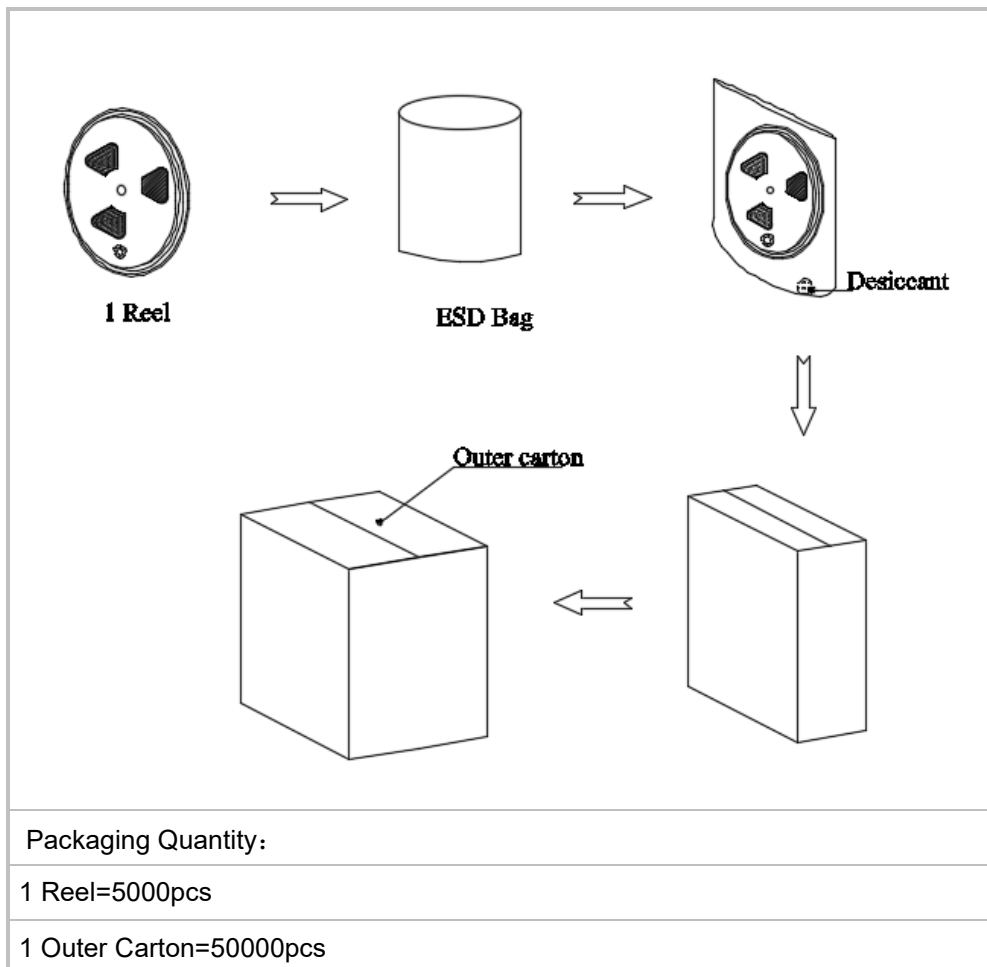

10. Reliability Test

The samples should be placed in the room with 23+/-2°C, 55+/-10%R.H. for 2 hours at least before final measurement, unless otherwise specified.

| Item | Detail | Standard |
|-----------------------------------|--|----------|
| Simulated Reflow (Without Solder) | Samples for qualification testing require 3 times 260±5°C reflow solder profiles. 2 hours of setting time is required between each reflow profile test. | ±3 dB |
| Static Humidity | Precondition at +25°C for 1 hour. Then expose to +85°C with 85% relative humidity for 240 hours. | ±3 dB |
| Temperature Shock | Each cycle shall consist of 30 minutes at -40°C, 30 minutes at +125°C with 5 minutes transition time. Test duration is for 30 cycles, starting from cold to hot temperature. | ±3 dB |
| ESD Sensitivity | According to MIL-STD-883G, Method 3015.7 for Human Body Model. Discharge Position: I/O pins Charge Voltage: ±3000V Discharge Network: 100pF & 1500Ω | ±3 dB |
| Random Vibrations | Vibrate randomly along three perpendicular directions for 30 minutes in each direction, 4 cycles from 20Hz~2000Hz with a peak acceleration 20g. | ±3 dB |
| Mechanical Shock | Subject samples to half sine shock pulses (3000g±15% for 0.3ms) in each direction, totally 18 shocks. | ±3 dB |
| High temperature Storage | Microphone unit must maintain sensitivity after storage at +105°C for 240 hours. | ±3 dB |
| Low temperature Storage | Microphone unit must maintain sensitivity after storage at -40°C for 240 hours. | ±3 dB |
| Drop Test | The test was repeated in six directions for 3 times, Dropped from 1.5m height on to a steel surface, total 18 times and inspected for mechanical damage. | ±3 dB |

Specification Revisions

| Revision | Description | Approved | Date |
|----------|----------------------|----------|------------|
| 1.1 | New Version Released | Hary | 17/05/2024 |
| | | | |
| | | | |
| | | | |
| | | | |
| | | | |
| | | | |
| | | | |
| | | | |
| | | | |
| | | | |
| | | | |
| | | | |
| | | | |
| | | | |
| | | | |
| | | | |
| | | | |
| | | | |
| | | | |
| | | | |