

SPTECH Silicon PNP Power Transistor

2SA1294

DESCRIPTION

- High Collector-Emitter Breakdown Voltage-
 $V_{(BR)CEO} = -230V(\text{Min})$
- Good Linearity of h_{FE}
- Complement to Type 2SC3263

APPLICATIONS

- Designed for audio and general purpose applications

ABSOLUTE MAXIMUM RATINGS($T_a=25^\circ\text{C}$)

SYMBOL	PARAMETER	VALUE	UNIT
V_{CBO}	Collector-Base Voltage	-230	V
V_{CEO}	Collector-Emitter Voltage	-230	V
V_{EBO}	Emitter-Base Voltage	-5	V
I_C	Collector Current-Continuous	-15	A
I_B	Base Current-Continuous	-4	A
P_C	Collector Power Dissipation @ $T_c=25^\circ\text{C}$	130	W
T_J	Junction Temperature	150	$^\circ\text{C}$
T_{stg}	Storage Temperature Range	-55~150	$^\circ\text{C}$

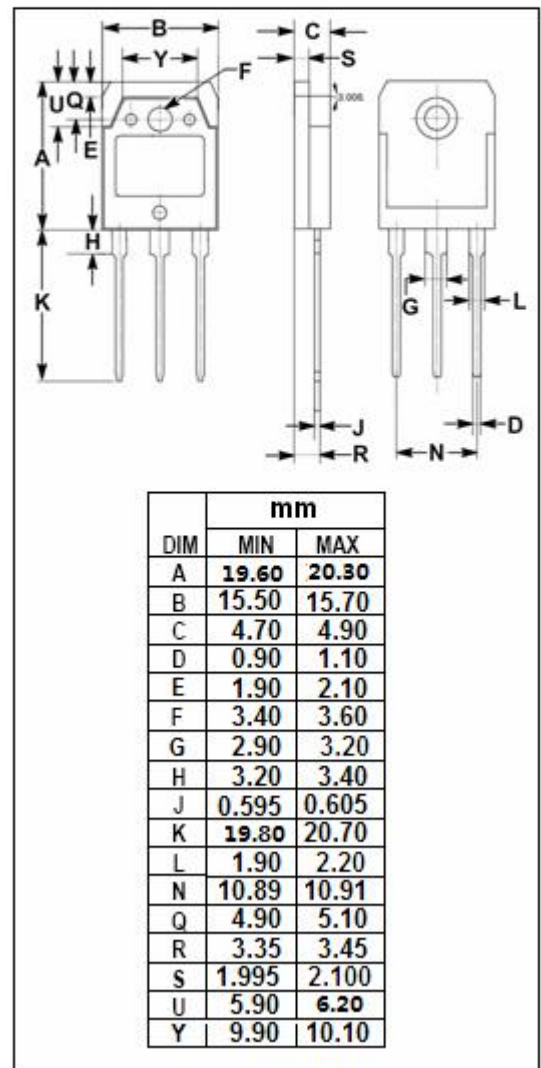
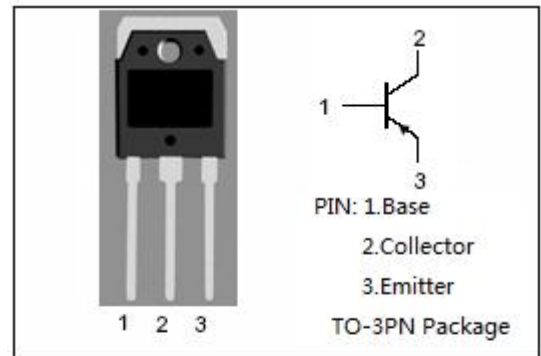

ELECTRICAL CHARACTERISTICS

$T_c=25^{\circ}\text{C}$ unless otherwise specified

SYMBOL	PARAMETER	CONDITIONS	MIN	TYP.	MAX	UNIT
$V_{(BR)CEO}$	Collector-Emitter Breakdown Voltage	$I_C = -25\text{mA}$; $I_B = 0$	-230			V
$V_{CE(sat)}$	Collector-Emitter Saturation Voltage	$I_C = -5.0\text{A}$; $I_B = -0.5\text{A}$			-2.0	V
I_{CBO}	Collector Cutoff Current	$V_{CB} = -230\text{V}$; $I_E = 0$			-100	μA
I_{EBO}	Emitter Cutoff Current	$V_{EB} = -5\text{V}$; $I_C = 0$			-100	μA
h_{FE}	DC Current Gain	$I_C = -5\text{A}$; $V_{CE} = -4\text{V}$	50		140	
C_{OB}	Output Capacitance	$I_E = 0$; $V_{CB} = -10\text{V}$; $f = 1.0\text{MHz}$		500		pF
f_T	Current-Gain—Bandwidth Product	$I_E = 2\text{A}$; $V_{CE} = -12\text{V}$		35		MHz

Switching Times

t_{on}	Turn-on Time	$I_C = -5\text{A}$, $R_L = 12\ \Omega$, $I_{B1} = -I_{B2} = -0.5\text{A}$, $V_{CC} = -60\text{V}$		0.35		μs
t_{stg}	Storage Time			1.5		μs
t_f	Fall Time			0.3		μs

◆ **h_{FE} Classifications**

O	Y
50-100	70-140