

1. Designed for long haul Gigabit Ethernet 1000 Base-T, full duplex applications.
2. Supports four pairs of category 5 UTP cable.
3. Cable interface for isolation and low common mode emissions
4. Compliant with IEEE 802.3ab standard for 1000 Base-T
5. Designed to support 1:1 Turns Ratio Transceivers.
6. Operating Temperature range: 0°C TO +70°C
7. Storage temperature range: -25°C TO +125°C

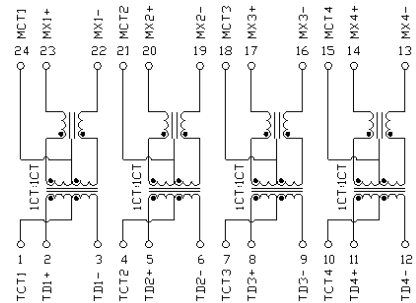

## DIMENSIONS & SCHEMATICS

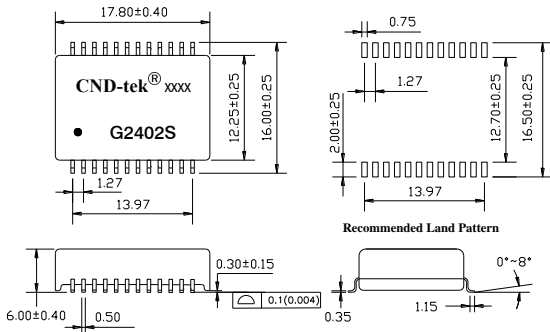

**Note:** 1. Dimension: mm, 2. Unless otherwise specified, tolerances are: ± 0.05mm

## TECHNICAL SPECIFICATIONS

OCL :	350 $\mu$ H Min. @ 100 KHz, 100mV with 8mA DC Bias
Leakage	0.5 $\mu$ H Max. @ 100KHz, 0.2V
Inductance: Cw/w:	28pF Max. @ 100KHz, 0.2V
DCR:	1.20 $\Omega$ Max.
Turns Ratio(±5%):	1CT:1CT(TX), 1CT:1CT(RX)
Polarity:	2-23, 5-20, 8-17, 11-14 In-Phase
Insertion Loss:	-1.1 dB Max. @ 1-100MHz
Return Loss:	-16dB Min. @ 1-30MHz -12 dB Min. @ 30-60 MHz -10 dB Min. @ 60-80 MHz
Cross Talk:	-42 dB Min. @ 1-60 MHz -35 dB Min. @ 60-100 MHz
Common Mode Rejection :	-42 dB Min. @ 1-30 MHz -35 dB Min. @ 60 MHz -30 dB Min. @ 80-100 MHz
Isolation HI-POT:	1500Vms 1mA 1Second

## PACKING SPECIFICATION

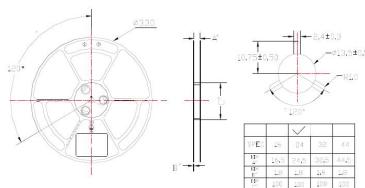

1. units/reel:420PCS
2. reel/carton:5PCS
3. units/carton :2100PCS

