

1. Designed for long haul 5G Double Port Transformer Module
2. Supports four pairs of category 5 UTP cable, Cable interface for isolation and low common mode emissions.
3. Low profile Surface Mount Packaging designed for Hi-Temp Reflow Process
4. Compliant with IEEE 802.3bz standard for 5G Base-Z, Designed to support 1:1 Turns Ratio Transceivers.

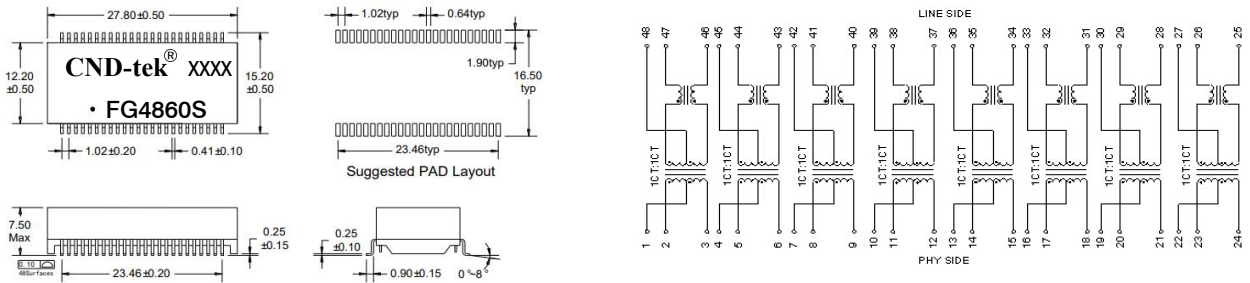

DIMENSIONS & SCHEMATICS



TECHNICAL SPECIFICATIONS

OCL :	150 μ H Min. @ 100 KHz, 100mV with 8mA DC Bias
Leakage Inductance:	0.35 μ H Max. @ 100KHz, 0.1V
Cw/w:	35pF Max. @ 100KHz, 0.1V
DCR:	0.90 Ω Max; Secondary: 1.2 Ω Max
Turns Ratio(\pm 5%):	1CT:1(TX), 1CT:1(RX)
Polarity:	1-48,4-45,7-42,10-39,13-36,16-33,19-30,22-27 In-Phase
Insertion Loss:	-1.0 dB Max. @ 1-100MHz -1.5dB Max. @ 100-150MHz -2.0dB Max. @ 150-200MHz
Return Loss:	-20dB Min. @ 1-40MHz -16dB Min. @ 40.1-100 MHz -10dB Min. @ 100.1-200 MHz
Cross Talk:	-30dB Min. @ 1-200MHz
Common Mode Rejection :	-30dB Min. @ 1-200MHz
Isolation HI-POT:	1500Vrms 1mA 60S or 1650VAC 1mA 6S
Operating Temperature range:	-40°C ~ +85°C
Storage temperature range:	-40°C ~ +125°C

PACKING SPECIFICATION

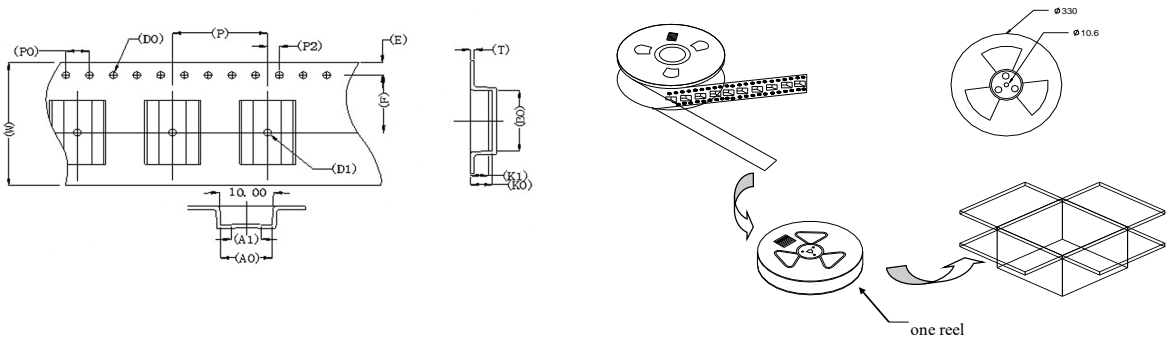

1. units/reel:300PCS
- 2 reel/carton:5PCS
- 3.units/carton :1500PCS