

Jan.1.2022 Copyright 2022 HIROSE ELECTRIC CO., LTD. All Rights Reserved.
In case of consideration for using Automotive equipment / device which demand high reliability, kindly contact our sales window correspondents.

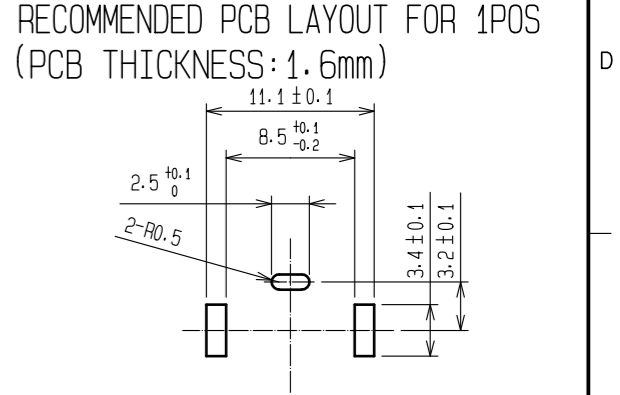
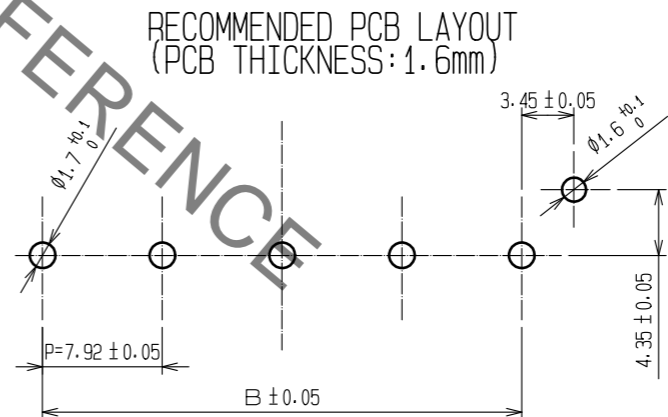
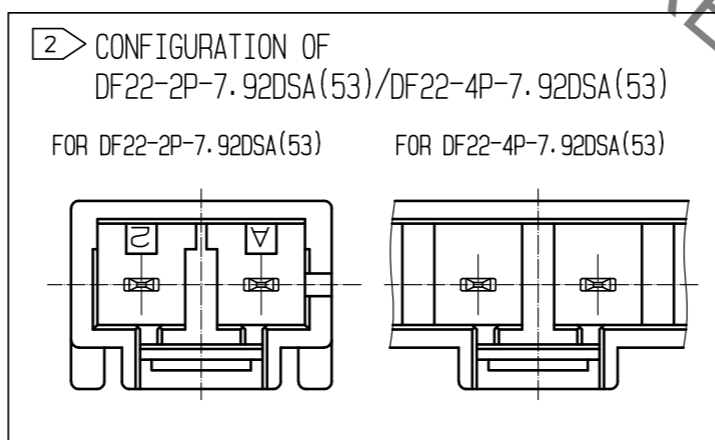
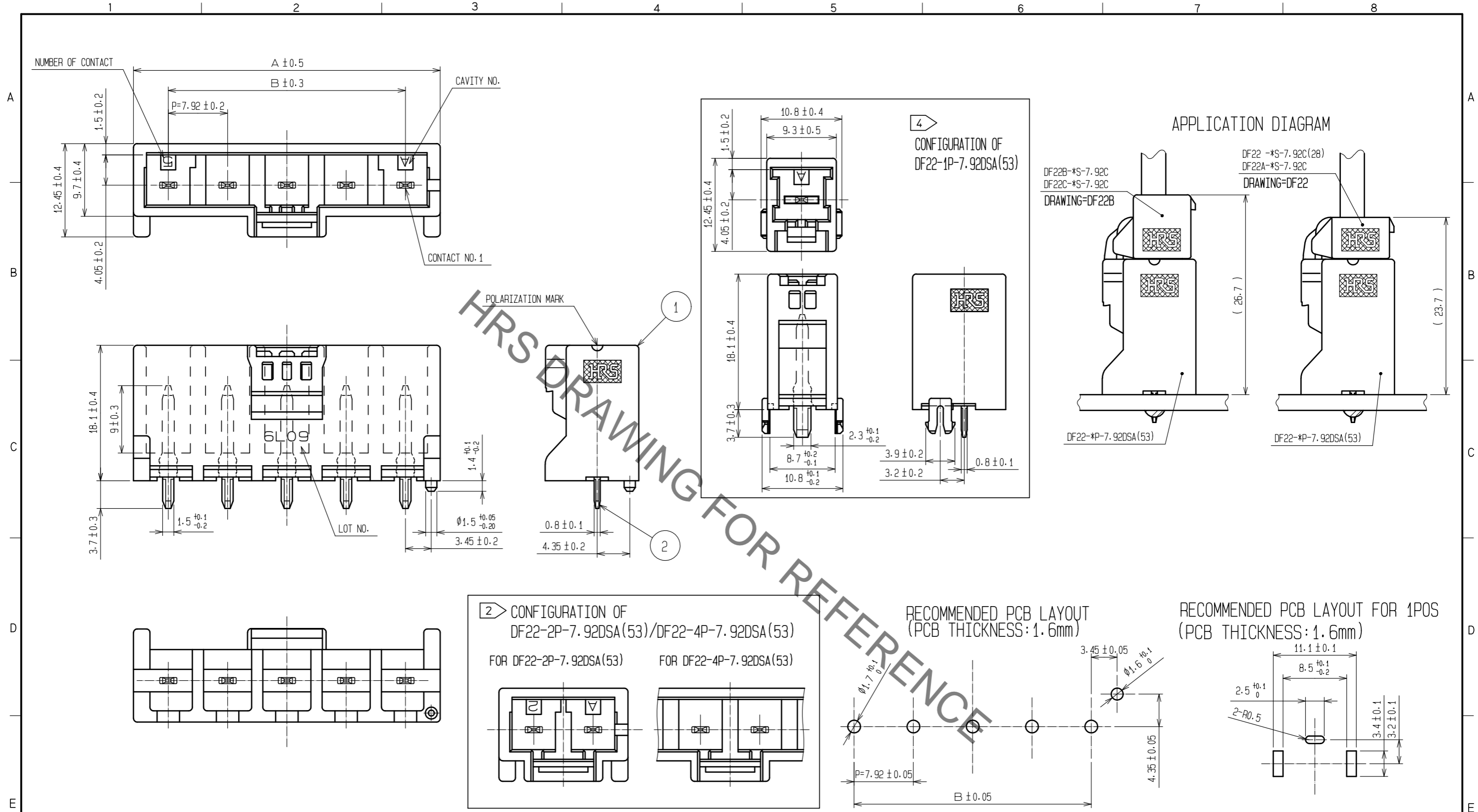

PART NO.	CL NO.	NUMBER OF CONTACT	A	B
DF22-1P-7.92DSA(53)	CL680-1013-5-53	1	-	-
DF22-2P-7.92DSA(53)	CL680-1014-8-53	2	17.22	7.92
DF22-3P-7.92DSA(53)	CL680-1015-0-53	3	25.14	15.84
DF22-4P-7.92DSA(53)	CL680-1016-3-53	4	33.06	23.76
DF22-5P-7.92DSA(53)	CL680-1017-6-53	5	40.98	31.68

NOTE 1:UL(FILE NO.E52653)
C-UL(FILE NO.E52653)
TUV(CERTIFICATE NO.R9950703)AUTHORIZATION ARTICLE.

HRS logo
2 > TWO AND FOUR CONTACTS ARE DIFFERENT SHAPE AS SHOWN.
3: PER PACK: 100PIECES
4 > CONFIGURATION OF ONE CONTACTS.

2	COPPER ALLOY	Contact area:Gold plating 0.2µm min Lead area:Tin plating 1µm min Under plating:Nickel plating 1µm min Other:Nickel plating 1µm min
1	POLYAMIDE	NATURAL (BEIGE)・UL94V-0

NO.	MATERIAL	FINISH	REMARKS	NO.	MATERIAL	FINISH	REMARKS			
UNITS mm			SCALE 2 : 1		DESCRIPTION OF REVISIONS			DESIGNED	CHECKED	DATE
HRS HIROSE ELECTRIC CO., LTD.				APPROVED : HS. OKAWA	20200309	DRAWING NO.		EDC-163719-53-00		
				CHECKED : SZ. ONO	20200309	PART NO.		DF22- * P-7.92DSA(53)		
				DESIGNED : SN. MIWA	20200309	CODE NO.		CL680-		
				DRAWN : DS. HIROWATARI	20200306			1/2		

Jan.1.2022 Copyright 2022 HIROSE ELECTRIC CO., LTD. All Rights Reserved.
In case of consideration for using Automotive equipment / device which demand high reliability, kindly contact our sales window correspondents.

Precautions

Notification for Insertion Extraction

- 1) Please insert(extract) the crimping socket straight to the mating connector.
Insertion(extraction) at tilted angles applies load concentration to the connector end and may cause deformation (at connection area, socket and header case, etc). There is firing risk using this kind of deformed connector.



Insertion(Extraction)

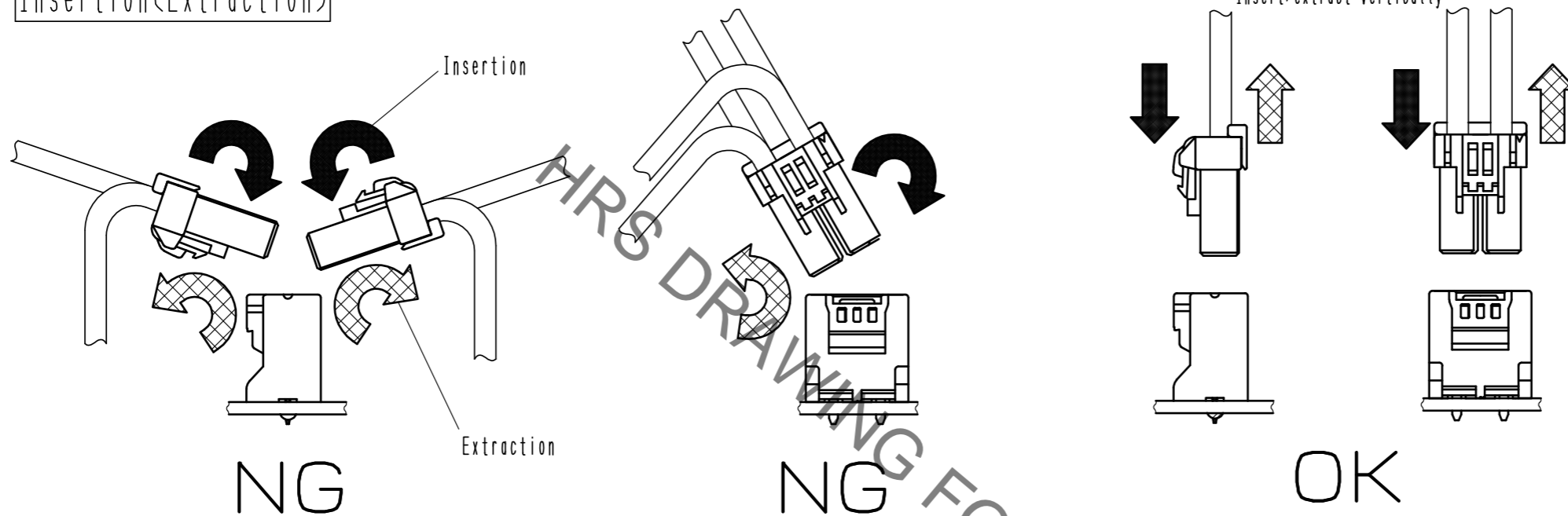

- 2) When it is hard to extract, please lightly insert the connector beforehand and then pull it with releasing the lock.
Forced extraction has a risk of connector breakage.

Notification of wiring



- 1) When using a thick cable, short cable length and bending close to the connector end, these load concentration may cause deformation.
Please note that there is firing risk using deformed connector.
When installing, please refrain from stress concentration such as cable bending close to the connector end or cable twisting.

Stress concentration:
Cable bending close to connector

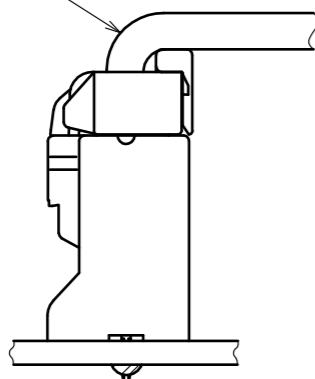

NG

No stress concentration:
No cable bending close to connector

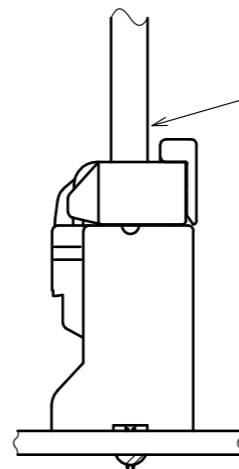

OK



- 2) Since this product uses thick wires, a larger load is applied to the connector when inserting/extracting or routing the wires.
Please use a retainer to reduce the load on the connector.



DRAWING NO.	EDC-163719-53-00
PART NO.	DF22-*P-7.92DSA(53)
CODE NO.	CL680-

