

1. DESCRIPTION

The XD/XL384x family of control ICs provides the necessary features to implement off-line or DC to DC fixed frequency current mode control schemes with a minimal external parts count. Internally implemented circuits include a trimmed oscillator for precise DUTY CYCLE CONTROL under voltage lock-out featuring start-up current less than 0.5mA, a precision reference trimmed for accuracy at the error amp input, logic to insure latched operation, a PWM comparator which also provides current limit control, and a totem pole output stage designed to source or sink high peak current. The output stage, suitable for driving N-Channel MOSFETs, is low in the off- state.

Differences between members of this family are the under-voltage lockout thresholds and maximum duty cycle ranges. The 3842 and 3844 have UVLO thresholds of 16V (on) and 10V (off), ideally suited off-line applications. The corresponding thresholds for the 3843 and 3845 are 8.5 V and 7.9 V. The 3842 and 3843 can operate to duty cycles approaching 100%. A range of the zero to < 50 % is obtained by the 3844 and 3845 by the addition of an internal toggle flip flop which blanks the output off every other clock cycle.

2. FEATURES

- Trimmed oscillator for precise frequency control
- Oscillator frequency guaranteed at 250kHz
- Current mode operation to 500kHz
- Automatic feed forward compensation
- Latching PWM for CYCLE-BY-CYCLE current limiting
- Internally trimmed reference with undervoltage lockout
- High current totem pole output
- Undervoltage lockout with hysteresis
- Low start-up and operating current

3. PIN CONNECTIONS AND FUNCTIONS

DIP8/SOP8

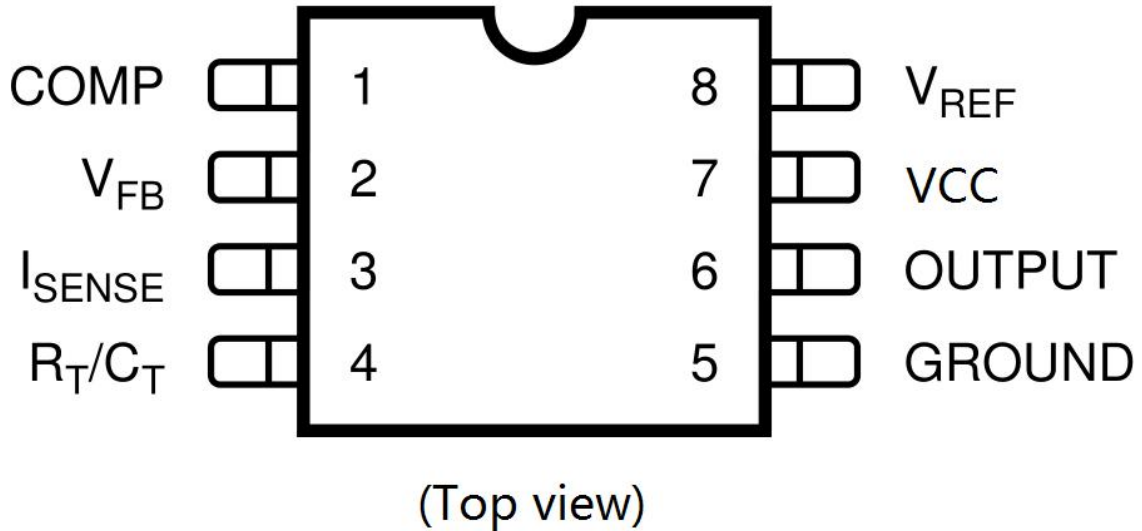

No	Function	Description
1	COMP	This pin is the Error Amplifier output and is made available for loop compensation.
2	V _{FB}	This is the inverting input of the Error Amplifier. It is normally connected to the switching power supply output through a resistor divider.
3	I _{SENSE}	A voltage proportional to inductor current is connected to this input. The PWM uses this information to terminate the output switch conduction.
4	R _T /C _T	The oscillator frequency and maximum Output duty cycle are programmed by connecting resistor R _T to V _{ref} and capacitor C _T to ground. Operation to 500kHz is possible.
5	GROUND	This pin is the combined control circuitry and power ground.
6	OUTPUT	This output directly drives the gate of a power MOSFET. Peak currents up to 1A are sourced and sunk by this pin.
7	V _{CC}	This pin is the positive supply of the control IC.
8	V _{REF}	This is the reference output. It provides charging current for capacitor C _T through resistor R _T .

4. BLOCK DIAGRAM

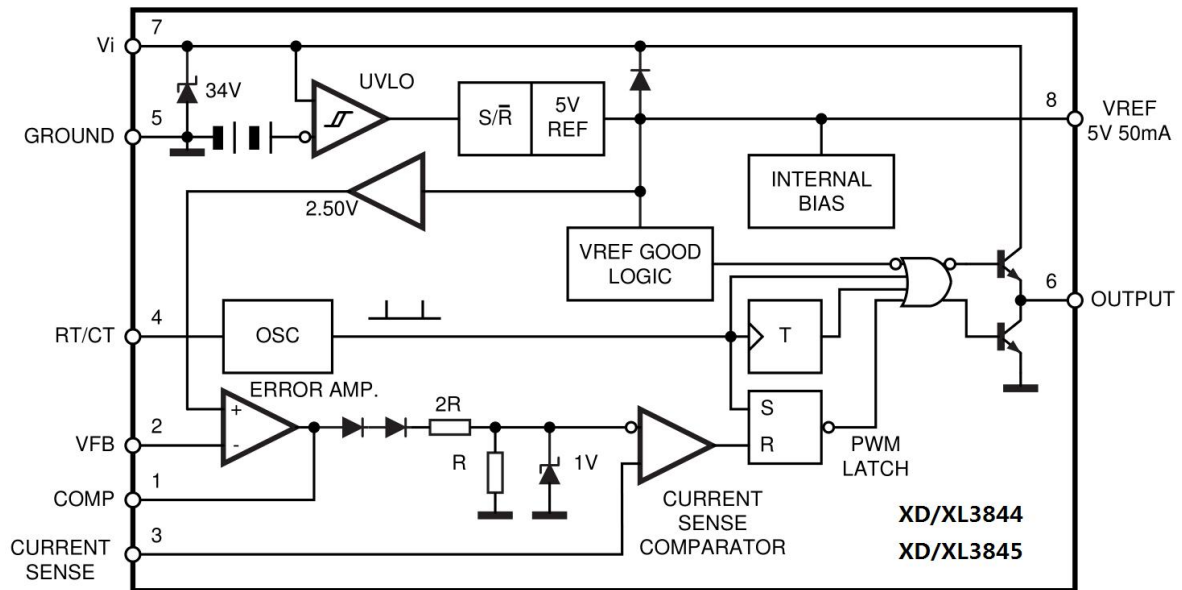

Notes: XD/XL3842 and XD/XL3843 don't have this part.

5. ABSOLUTE MAXIMUM RATINGS

Symbol	Parameter	Value	Unit
V _i	Supply Voltage (low impedance source)	30	V
V _i	Supply Voltage (I _i < 30mA)	Self Limiting	–
I _o	Output Current	±1	A
E _o	Output Energy (capacitive load)	5	μJ
	Analog Inputs (pins 2, 3)	– 0.3 to 5.5	V
	Error Amplifier Output Sink Current	10	mA
P _{tot}	Power Dissipation at T _{amb} ≤ 25 °C (Minidip)	1.25	W
P _{tot}	Power Dissipation at T _{amb} ≤ 25 °C (SO8)	800	mW
T _{stg}	Storage Temperature Range	– 65 to 150	°C
T _J	Junction Operating Temperature	– 40 to 150	°C
T _L	Lead Temperature (soldering 10s)	300	°C

* All voltages are with respect to pin 5, all currents are positive into the specified terminal.

(1) Stresses beyond those listed under Absolute Maximum Ratings may cause permanent damage to the device. These are stress ratings only, which do not imply functional operation of the device at these or any other conditions beyond those indicated under Recommended Operating Condition. Exposure to absolute-maximum-rated conditions for extended periods may affect device reliability.

6. RECOMMENDED OPERATING CONDITIONS

Over operating free-air temperature range (unless otherwise noted)

		Min	Typ	Max	Unit
V _{VCC} and V _{VC} ⁽¹⁾	Supply voltage	12		28	V
V _{VFB}	Input voltage			2.5	V
V _{ISENSE}	Input voltage			1	V
I _{VCC}	Supply current,externally limited			25	mA
I _{OUTPUT}	Average output current			200	mA
I _{VREF}	Reference output current			-20	mA
f _{OSC}	Oscillator frequency		100	500	KHZ
T _A	Operating free-air temperature	284x	-25	85	°C
		384x	0	70	

(1) These recommend voltages for VC and POWER GROUND apply only to the D package.

7. THERMAL DATA

Symbol	Description	DIP8	SOP8	Unit
R _{th J-amb}	Thermal Resistance Junction-ambient.	100	150	°C/W

8. ELECTRICAL CHARACTERISTICS

([note 1] Unless otherwise stated, these specifications apply for
-25 ≤ T_{amb} ≤ 85°C for XD/XL284X; 0 ≤ T_{amb} ≤ 70°C for XD/XL384X; V_i = 15V (note 5); R_T = 10K; C_T = 3.3nF)

Symbol	Parameter	Test Conditions	284X			384X			Unit
			Min.	Typ.	Max.	Min.	Typ.	Max.	
REFERENCE SECTION									
V _{REF}	Output Voltage	T _j = 25°C I _o = 1mA	4.95	5.00	5.05	4.90	5.00	5.10	V
ΔV _{REF}	Line Regulation	12V ≤ V _i ≤ 25V	-	8	20	-	8	20	mV
ΔV _{REF}	Load Regulation	1 ≤ I _o ≤ 20mA	-	8	25	-	8	25	mV
ΔV _{REF} /ΔT	Temperature Stability	(Note 2)	-	0.2	-	-	0.2	-	mV/°C
-	Total Output Variation	Line, Load, Temperature	4.9	-	5.1	4.82	-	5.18	V
e _N	Output Noise Voltage	10Hz ≤ f ≤ 10KHz T _j = 25°C (note 2)	-	50	-	-	50	-	μV
-	Long Term Stability	T _{amb} = (note 2) 125°C 1000Hrs	-	7	30	-	7	30	mV
I _{SC}	Output Short Circuit	-	-30	-100	-180	-30	-100	-180	mA
OSCILLATOR SECTION									
f _{OSC}	Initial accuracy	T _j = 25°C	38	52	65	38	52	65	KHz
Δf _{OSC} /ΔV	Frequency Change with Volt.	V _{CC} = 12V to 25V	-	0.6	5	-	0.6	5	%
Δf _{OSC} /ΔT	Frequency Change with Temp.	T _A = T _{low} to T _{high}	-	1	-	-	0.5	-	%
V _{OSC}	Oscillator Voltage Swing	(peak to peak)	-	1.6	-	-	1.6	-	V
I _{dischg}	Discharge Current (V _{OSC} = 2V)	T _j = 25°C	7.8	8.3	8.8	7.8	8.3	8.8	mA
		T _A = T _{low} to T _{high}	7.5	-	8.8	7.6	-	8.8	mA
ERROR AMP SECTION									
V ₂	Input Voltage	V _{PIN1} = 2.5V	2.45	2.50	2.55	2.42	2.50	2.58	V
I _b	Input Bias Current	V _{FB} = 5V	-	-0.1	-1	-	-0.1	-2	μA
	A _{VOL}	2V ≤ V _o ≤ 4V	65	90	-	65	90	-	dB
BW	Unity Gain Bandwidth	T _j = 25°C	0.7	1	-	0.7	1	-	MHz
PSRR	Power Supply Rejec. Ratio	12V ≤ V _i ≤ 25V	60	70	-	60	70	-	dB
I _o	Output Sink Current	V _{PIN2} = 2.7V V _{PIN1} = 1.1V	2	6	-	2	6	-	mA
I _o	Output Source Current	V _{PIN2} = 2.3V V _{PIN1} = 5V	-0.5	-1	-	-0.5	-1	-	mA
-	V _{OUT} High	V _{PIN2} = 2.3V; R _L = 15KΩ to Ground	5	6.2	-	5	6.2	-	V
-	V _{OUT} Low	V _{PIN2} = 2.7V; R _L = 15KΩ to Pin 8	-	0.8	1.1	-	0.8	1.1	V
CURRENT SENSE SECTION									
G _V	Gain	(note 3 & 4)	2.85	3	3.15	2.85	3	3.15	V/V
V ₃	Maximum Input Signal	V _{PIN1} = 5V (note 3)	0.9	1	1.1	0.9	1	1.1	V
SVR	Supply Voltage Rejection	12 ≤ V _i ≤ 25V (note 3)	-	70	-	-	70	-	dB
I _b	Input Bias Current	-	-	-2	-10	-	-2	-10	μA
-	Delay to Output	-	-	150	300	-	150	300	ns

ELECTRICAL CHARACTERISTICS (continued)

Symbol	Parameter	Test Conditions	284X			384X			Unit
			Min.	Typ.	Max.	Min.	Typ.	Max.	
OUTPUT SECTION									
V _{OL}	Output Low Level	I _{SINK} = 20mA	–	0.1	0.4	–	0.1	0.4	V
		I _{SINK} = 200mA	–	1.6	2.2	–	1.6	2.2	V
V _{OH}	Output High Level	I _{SOURCE} = 20mA	13	13.5	–	13	13.5	–	V
		I _{SOURCE} = 200mA	12	13.5	–	12	13.5	–	V
V _{OLS}	UVLO Saturation	VCC = 6V; I _{SINK} = 1mA	–	0.1	1.1	–	0.1	1.1	V
t _r	Rise Time	T _j = 25°C C _L = 1nF (2)	–	50	150	–	50	150	ns
t _f	Fall Time	T _j = 25°C C _L = 1nF (2)	–	50	150	–	50	150	ns
UNDER-VOLTAGE LOCKOUT SECTION									
–	Start Threshold	X842/4	14.5	16	17.5	14.5	16	17.5	V
		X843/5	7.8	8.4	9.0	7.8	8.4	9.0	V
–	Min Operating Voltage After Turn-on	X842/4	8.5	10	11.5	8.5	10	11.5	V
		X843/5	7.0	7.6	8.2	7.0	7.6	8.2	V
PWM SECTION									
–	Maximum Duty Cycle	X842/3	94	96	100	94	96	100	%
		X844/5	43	48	50	45	48	50	%
–	Minimum Duty Cycle	–	–	0	–	–	0	%	
TOTAL STANDBY CURRENT									
I _{st}	Start-up Current	VCC = 6.5V for X843/45	–	0.3	0.5	–	0.3	0.5	mA
		VCC = 14V for X842/44	–	0.3	0.5	–	0.3	0.5	mA
I _i	Operating Supply Current	V _{PIN2} = V _{PIN3} = 0V	–	12	20	–	12	20	mA
V _{iz}	Zener Voltage	I _i = 25mA	30	34	–	34	–	–	V

- Notes :**
1. Max package power dissipation limits must be respected; low duty cycle pulse techniques are used during test maintain T_j as close to T_{amb} as possible.
 2. These parameters, although guaranteed, are not 100% tested in production.
 3. Parameter measured at trip point of latch with V_{PIN2} = 0.
 4. Gain defined as :

$$A = \frac{\Delta V_{PIN1}}{\Delta V_{PIN3}} ; 0 \leq V_{PIN3} \leq 0.8V$$
 5. Adjust V_i above the start threshold before setting at 15 V.

Figure 1: Open Loop Test Circuit.

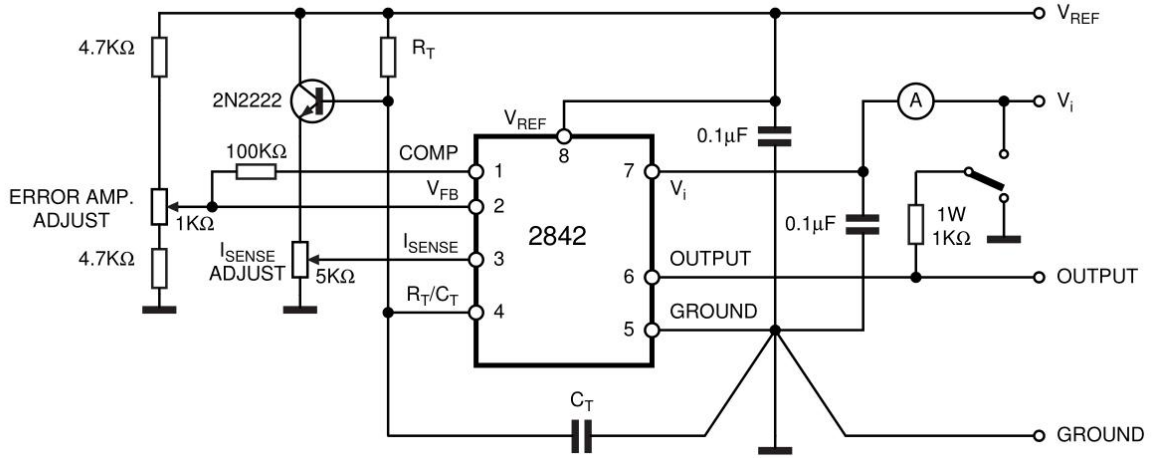

High peak currents associated with capacitive loads necessitate careful grounding techniques. Timing and bypass capacitors should be connected close to pin 5 in a single point ground. The transistor and 5 KΩ potentiometer are used to sample the oscillator waveform and apply an adjustable ramp to pin 3.

Figure 2: Timing Resistor vs. Oscillator Frequency

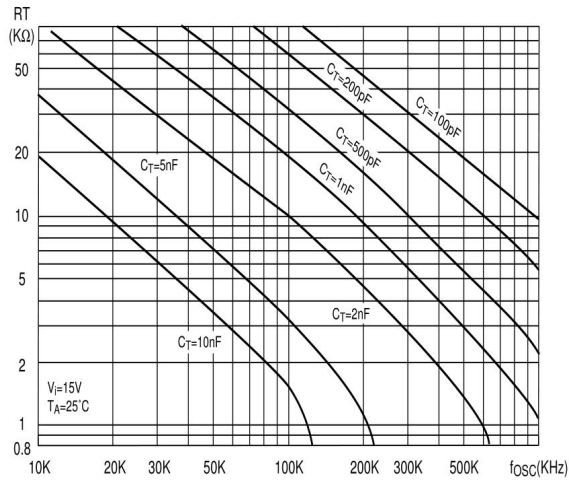

Figure 3: Output Dead-Time vs. Oscillator Frequency

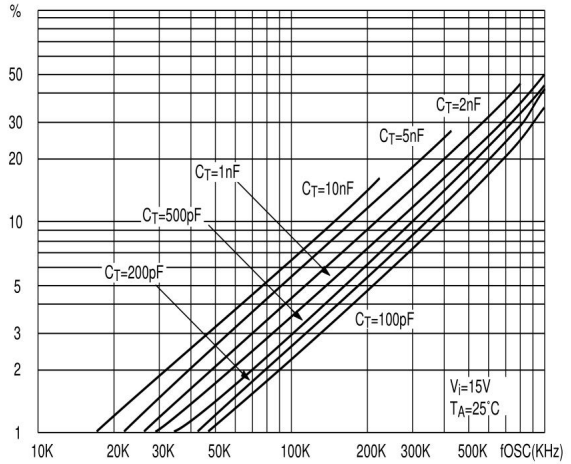

Figure 4: Oscillator Discharge Current vs. Temperature.

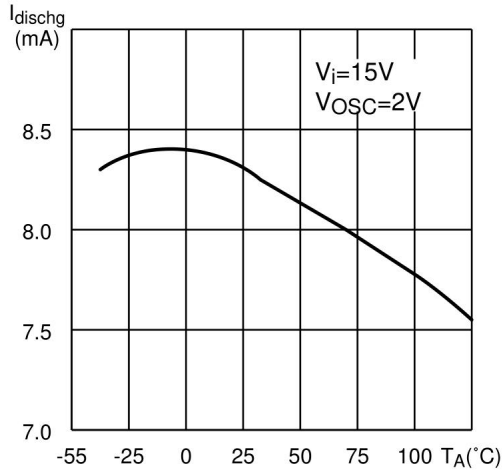

Figure 5: Maximum Output Duty Cycle vs. Timing Resistor.

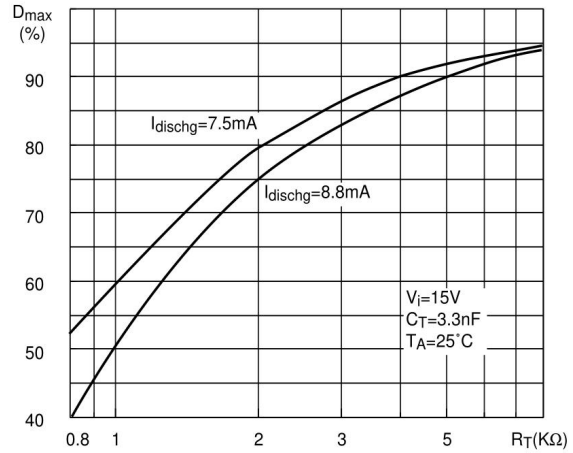

Figure 6: Error Amp Open-Loop Gain and Phase vs. Frequency.

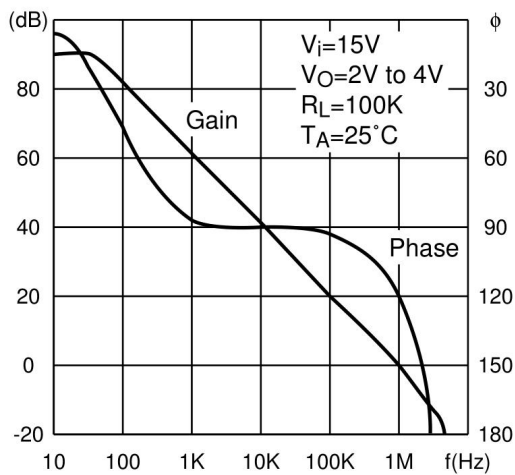

Figure 7: Current Sense Input Threshold vs. Error Amp Output Voltage.

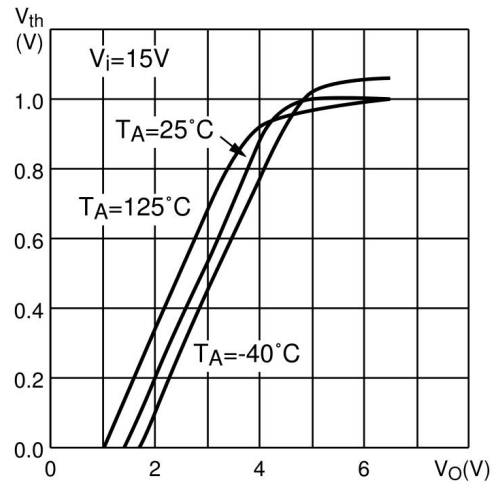

Figure 8: Reference Voltage Change vs. Source Current.

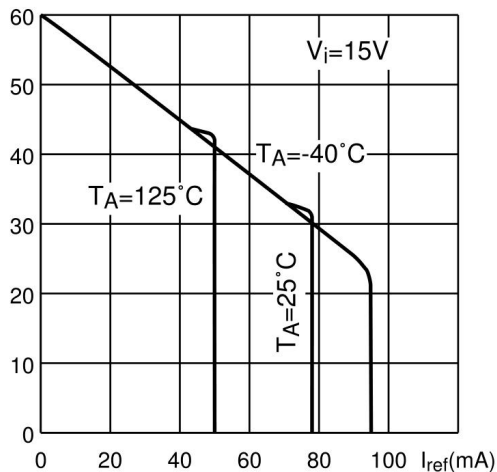

Figure 9: Reference Short Circuit Current vs. Temperature.

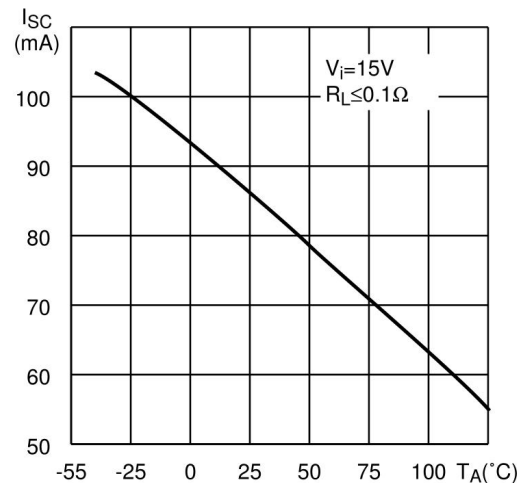

Figure 10: Output Saturation Voltage vs. Load Current.

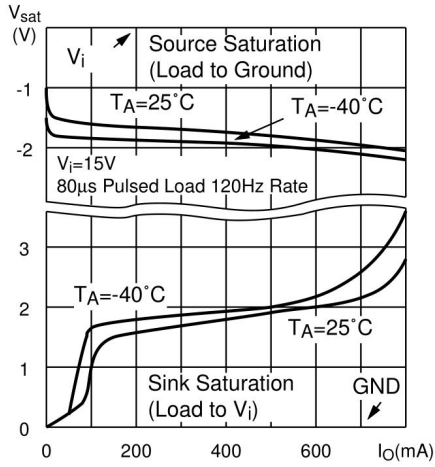

Figure 11: Supply Current vs. Supply Voltage.

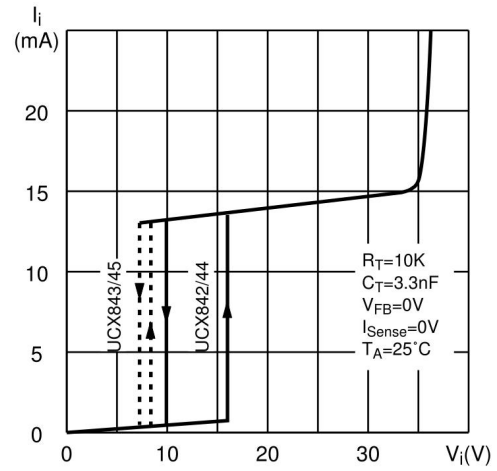

Figure 12: Output Waveform.

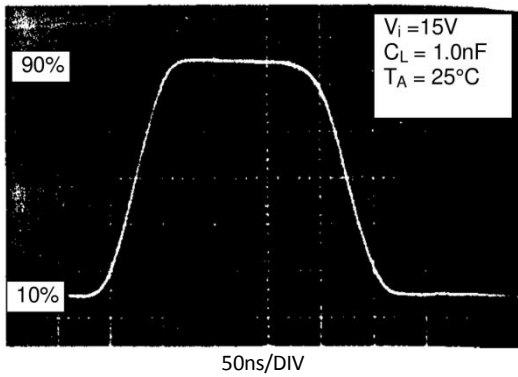

Figure 13: Output Cross Conduction

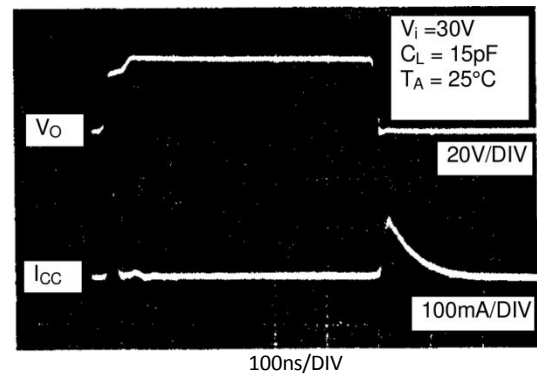

Figure 14: Oscillator and Output Waveforms.

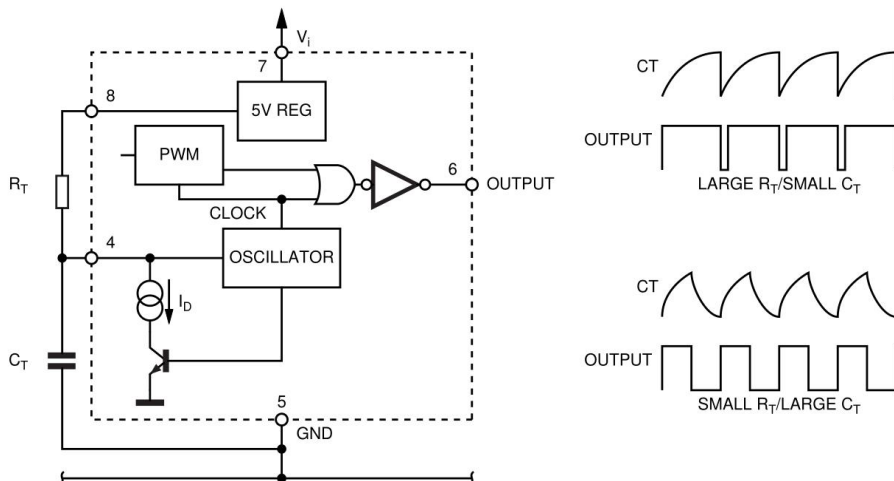

Figure 15 : Error Amp Configuration.

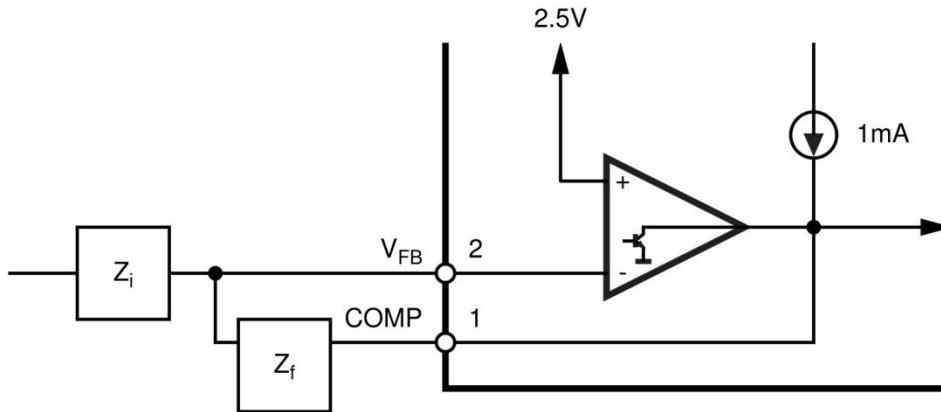

Figure 16 : Under Voltage Lockout.

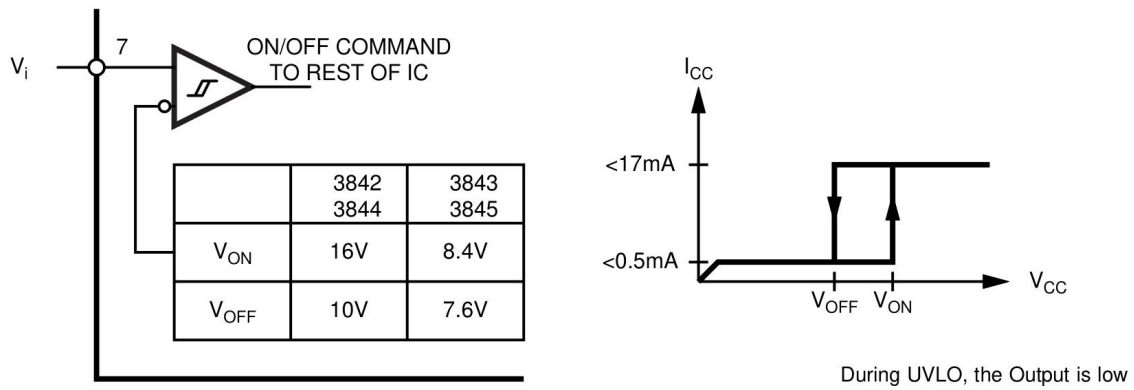
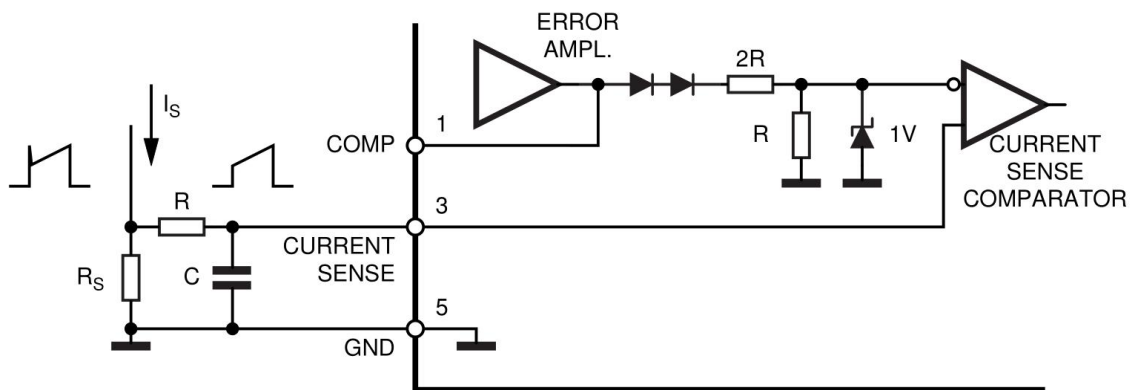

Figure 17 : Current Sense Circuit .



Peak current (i_s) is determined by the

$$\text{formula } I_{s \max} \approx \frac{1.0V}{R_s}$$

A small RC filter may be required to suppress switch transients.

Figure 18 : Slope Compensation

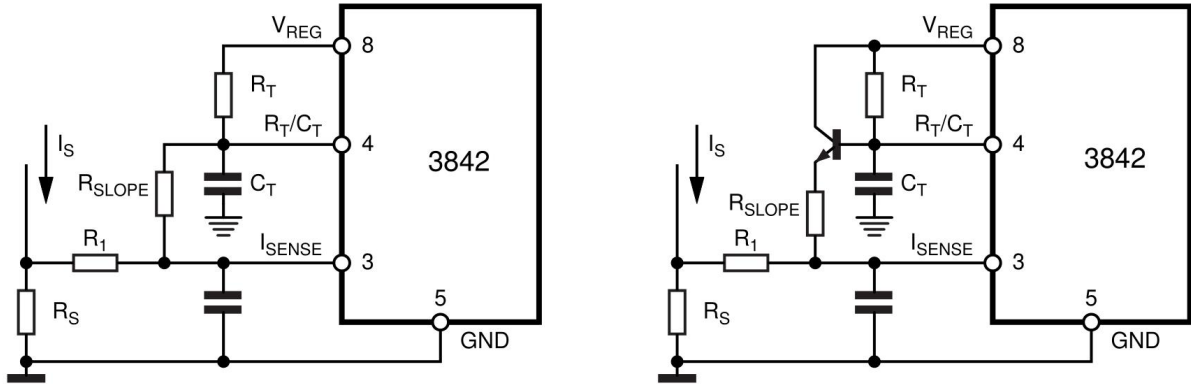

Figure 19 : Isolated MOSFET Drive and Current Transformer Sensing.

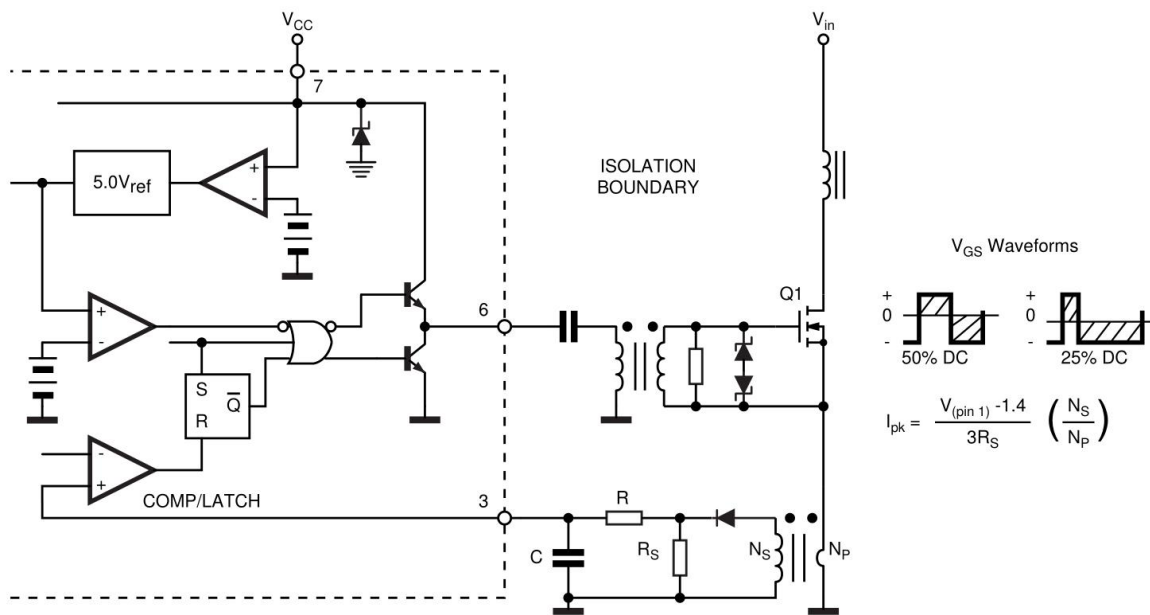
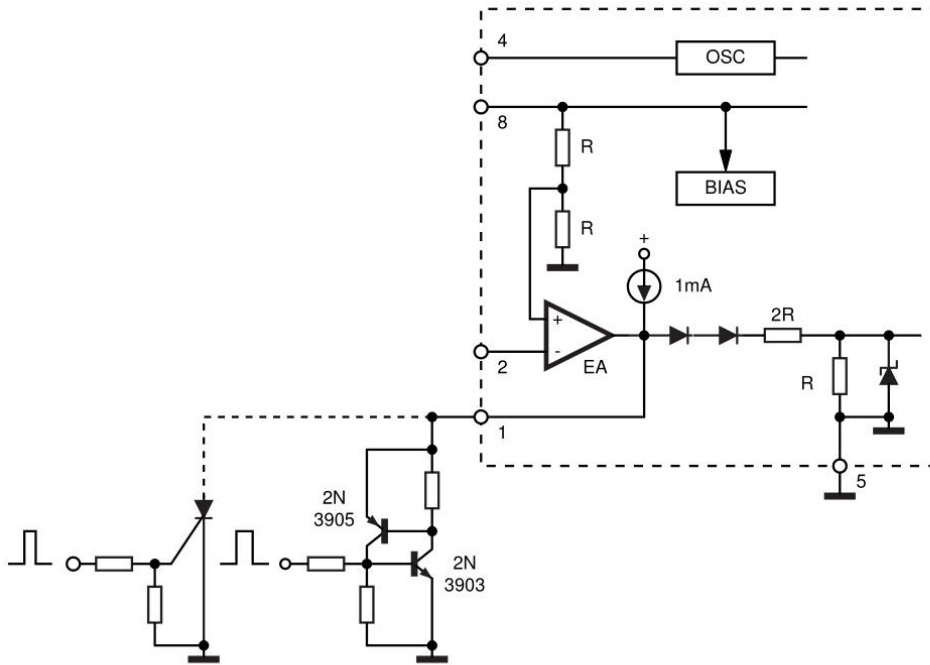
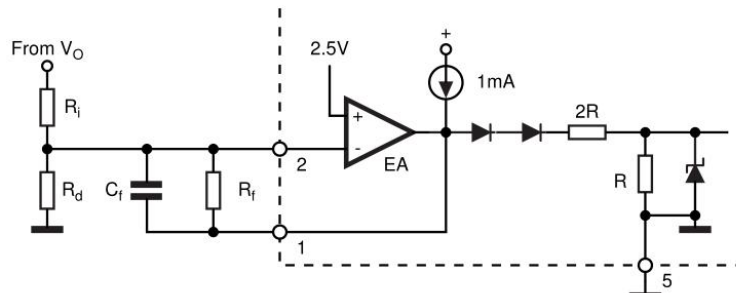

Figure 20 : Latched Shutdown.



SCR must be selected for a holding current of less than 0.5mA at $T_{A(min)}$.
The simple two transistor circuit can be used in place of the SCR as shown. All resistors are 10K.

Figure 21: Error Amplifier Compensation



Error Amp compensation circuit for stabilizing any current-mode topology except for boost and flyback converters operating with continuous inductor current.

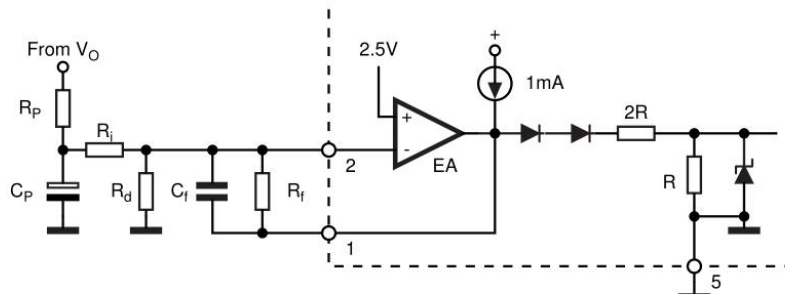

Error Amp compensation circuit for stabilizing current-mode boost and flyback topologies operating with continuous inductor current.

Figure 22: External Clock Synchronization.

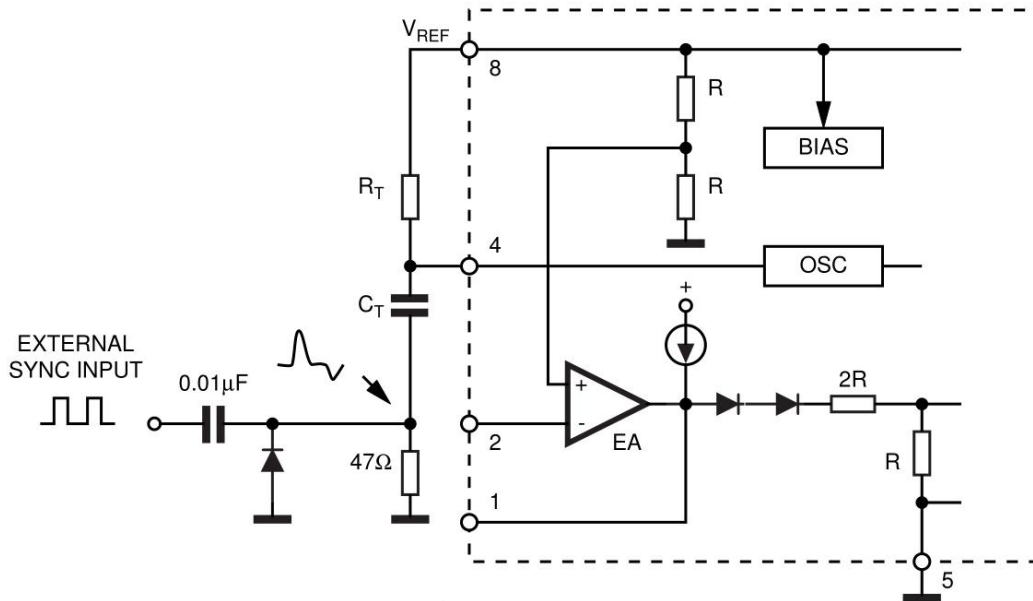

The diode clamp is required if the Sync amplitude is large enough to cause the bottom side of C_T to go more than 300mV below ground

Figure 23: External Duty Cycle Clamp and Multi Unit Synchronization.

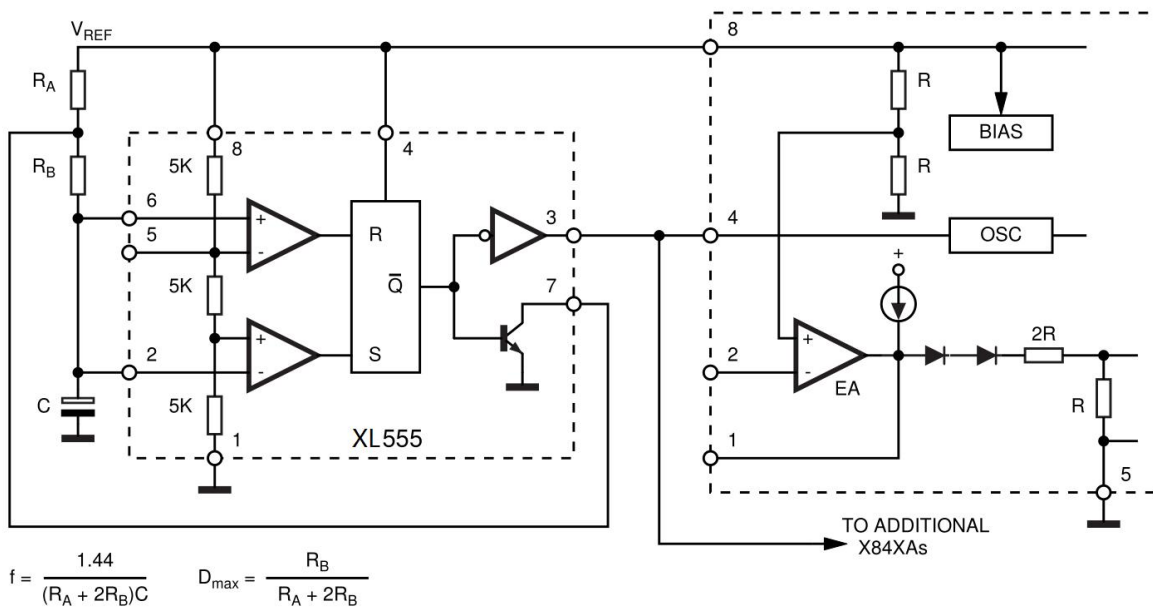

Figure 24: Soft-Start Circuit

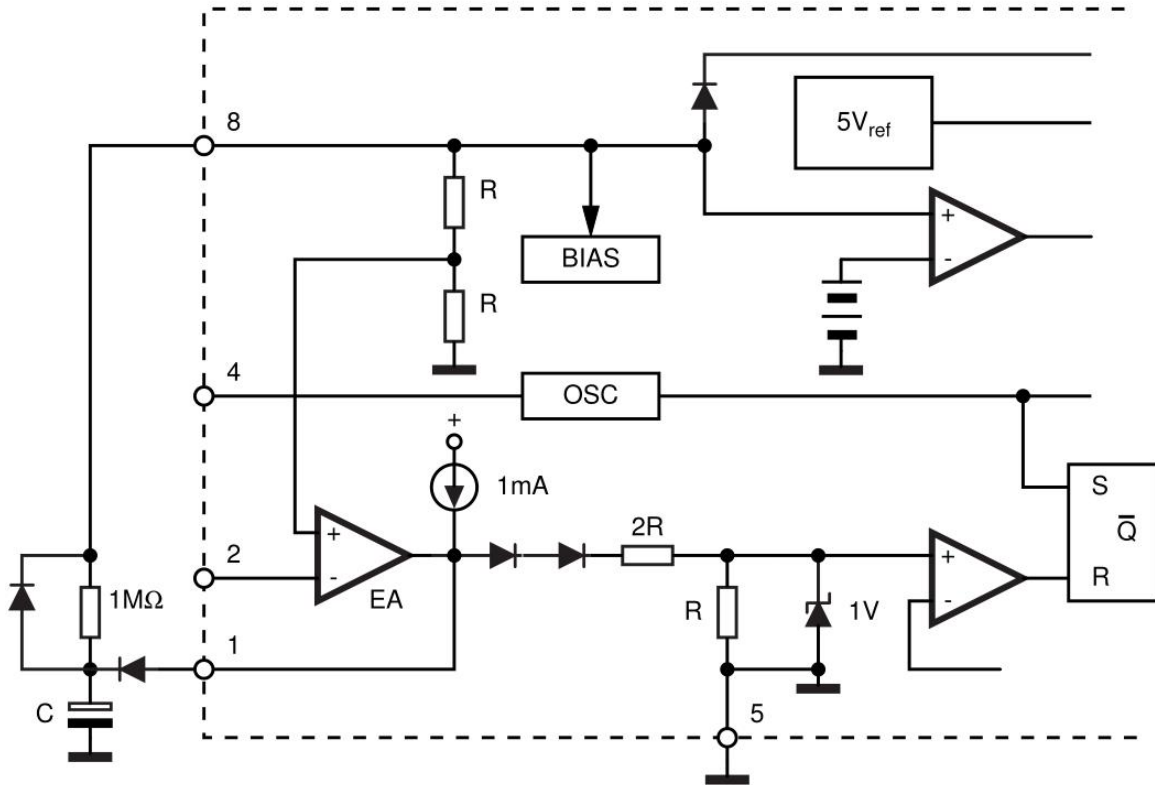
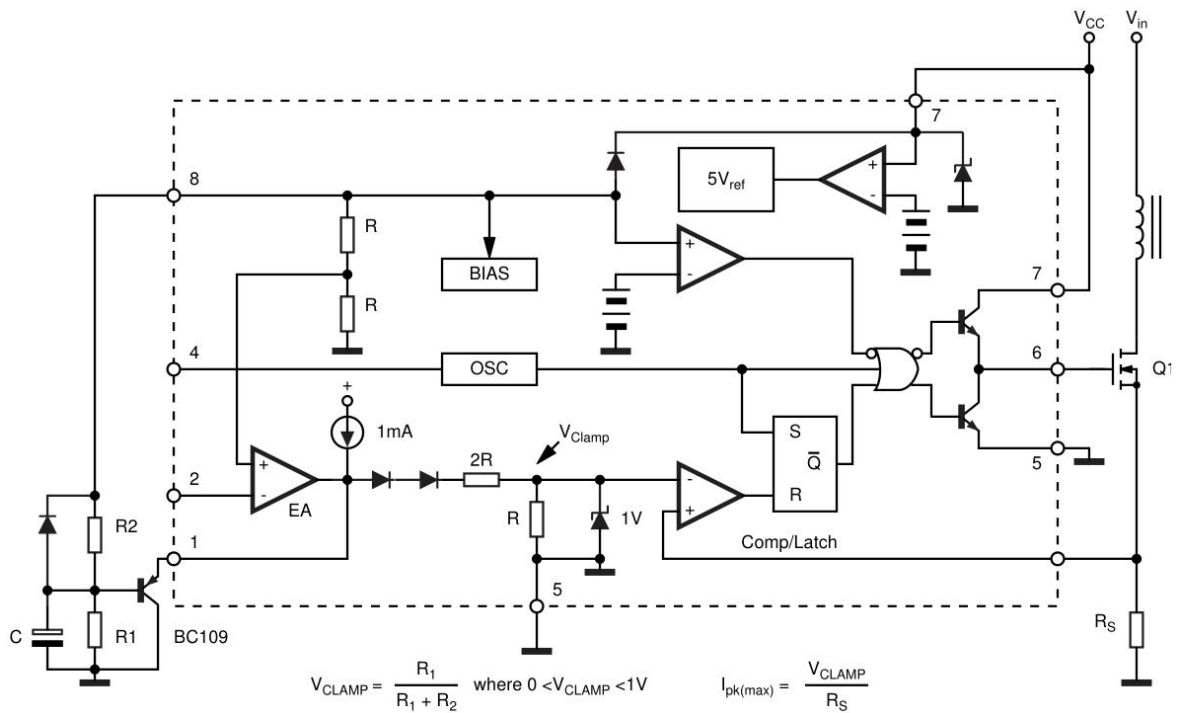

Figure 25: Soft-Start and Error Amplifier Output Duty Cycle Clamp.



9. ORDERING INFORMATION

Ordering Information

Part Number	Device Marking	Package Type	Body size (mm)	Temperature (°C)	MSL	Transport Media	Package Quantity
XL2842	XL2842	SOP8	4.90 * 3.90	- 25 to 85	MSL3	T&R	2500
XL3842	XL3842	SOP8	4.90 * 3.90	- 0 to 70	MSL3	T&R	2500
XL2843	XL2843	SOP8	4.90 * 3.90	- 25 to 85	MSL3	T&R	2500
XL3843	XL3843	SOP8	4.90 * 3.90	- 0 to 70	MSL3	T&R	2500
XD3843	XD3843	DIP8	9.25 * 6.38	- 0 to 70	MSL3	Tube 50	2000
XL2844	XL2844	SOP8	4.90 * 3.90	- 25 to 85	MSL3	T&R	2500
XL3844	XL3844	SOP8	4.90 * 3.90	- 0 to 70	MSL3	T&R	2500
XL2845	XL2845	SOP8	4.90 * 3.90	- 25 to 85	MSL3	T&R	2500
XL3845	XL3845	SOP8	4.90 * 3.90	- 0 to 70	MSL3	T&R	2500
XD3845	XD3845	DIP8	9.25 * 6.38	- 0 to 70	MSL3	Tube 50	2000

10. DIMENSIONAL DRAWINGS

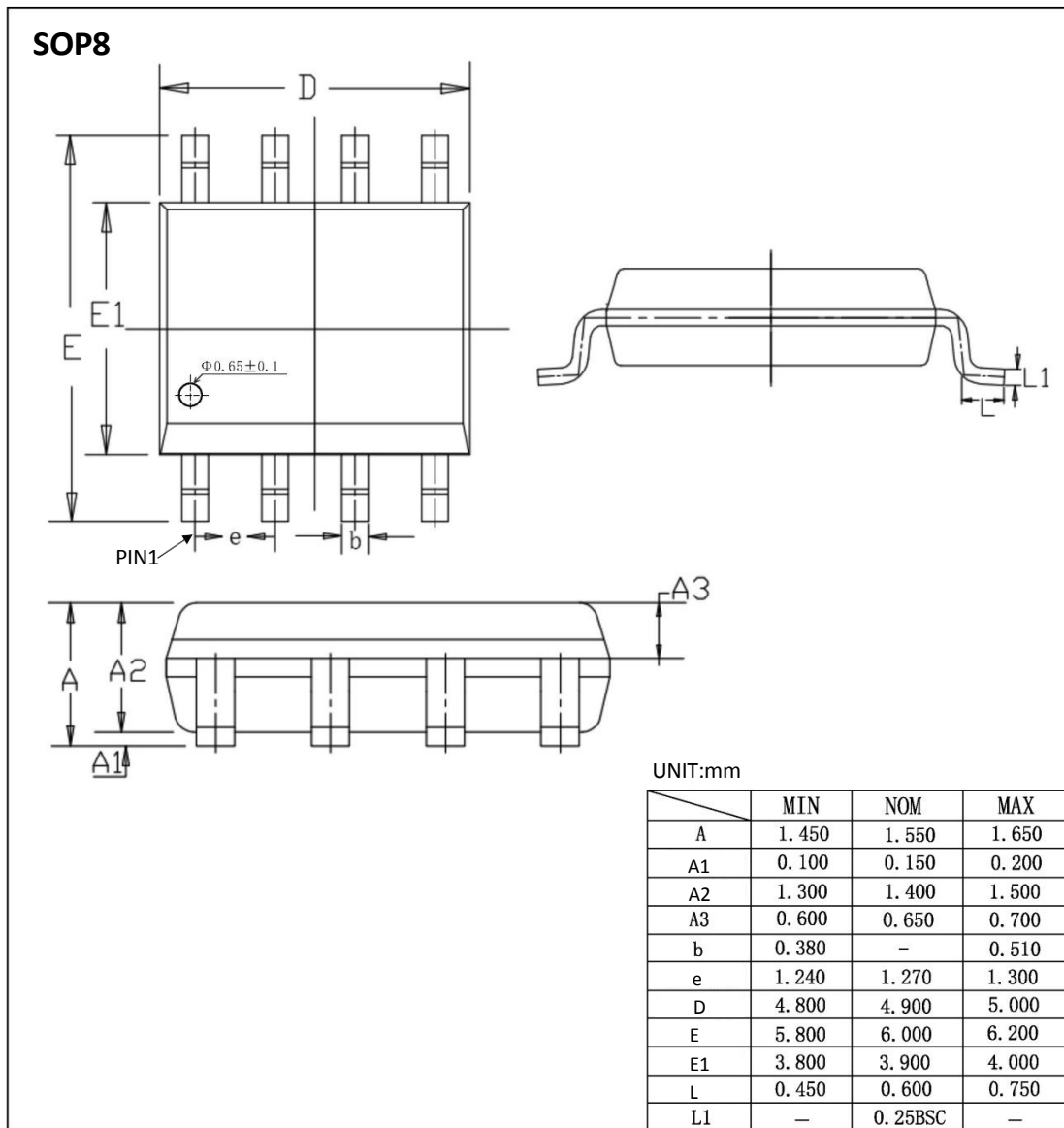

DIP8

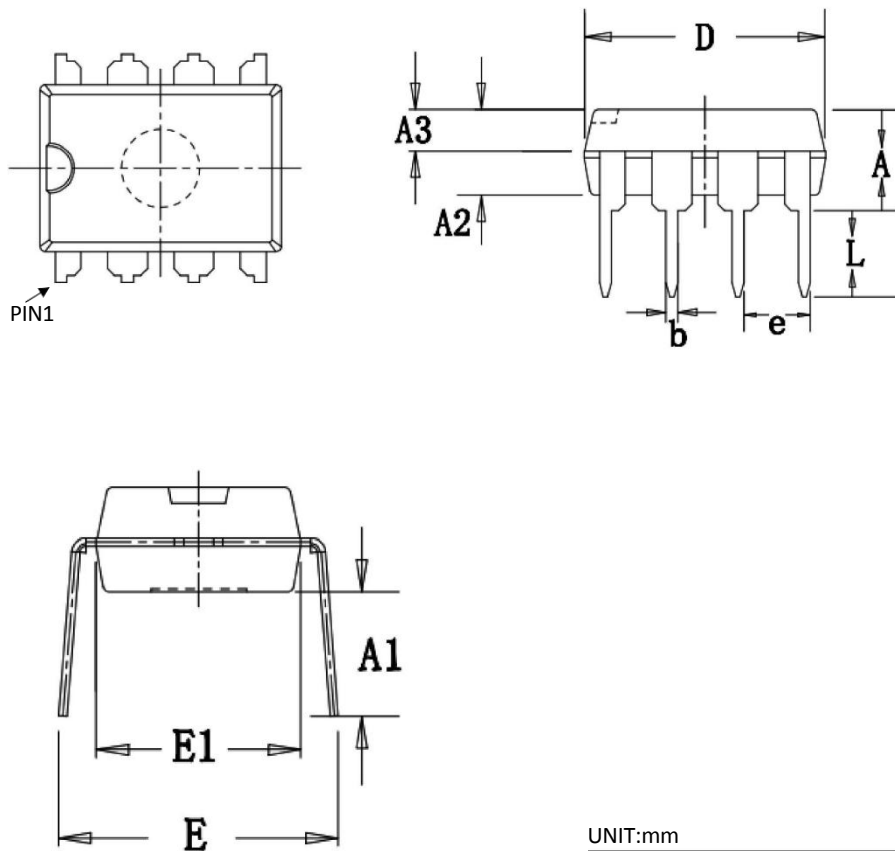

UNIT:mm

	MIN	NOM	MAX
A	3.600	3.800	4.000
A1	3.786	3.886	3.986
A2	3.200	3.300	3.400
A3	1.550	1.600	1.650
b	0.440	—	0.490
e	2.510	2.540	2.570
D	9.150	9.250	9.350
E	7.800	8.500	9.200
E1	6.280	6.380	6.480
L	3.000	—	—

[if you need help contact us. Xinluda reserves the right to change the above information without prior notice]