

1. DESCRIPTION

Recommended for high-side switching applications that benefit from separate logic and load grounds, these devices encompass load supply voltages to 50 V and output currents to -500 mA. These 8-channel source drivers are useful for interfacing between low-level logic and high-current loads. Typical loads include relays, solenoids, lamps, stepper and/or servo motors, print hammers, and LEDs.

All devices may be used with 5 V logic systems — TTL, Schottky TTL, DTL, and 5 V CMOS. The device packages offered are electrically interchangeable, and will withstand a maximum output off voltage of 50 V, and operate to a minimum of 5 V. All devices in this series integrate input current limiting resistors and output transient suppression diodes, and are activated by an active high input.

The package is a 20-pin wide-body SOP with improved thermal characteristics compared to the 18-pin SOP version it replaces (100% pin-compatible electrically).

The package is lead (Pb) free, with 100% matte-tin leadframe plating.

2. FEATURES

- TTL, DTL, PMOS, or CMOS compatible inputs
- 500 mA output source current capability
- Transient-protected outputs
- Output breakdown voltage to 50 V
- SOP packaging

3. FUNCTIONAL BLOCK DIAGRAM

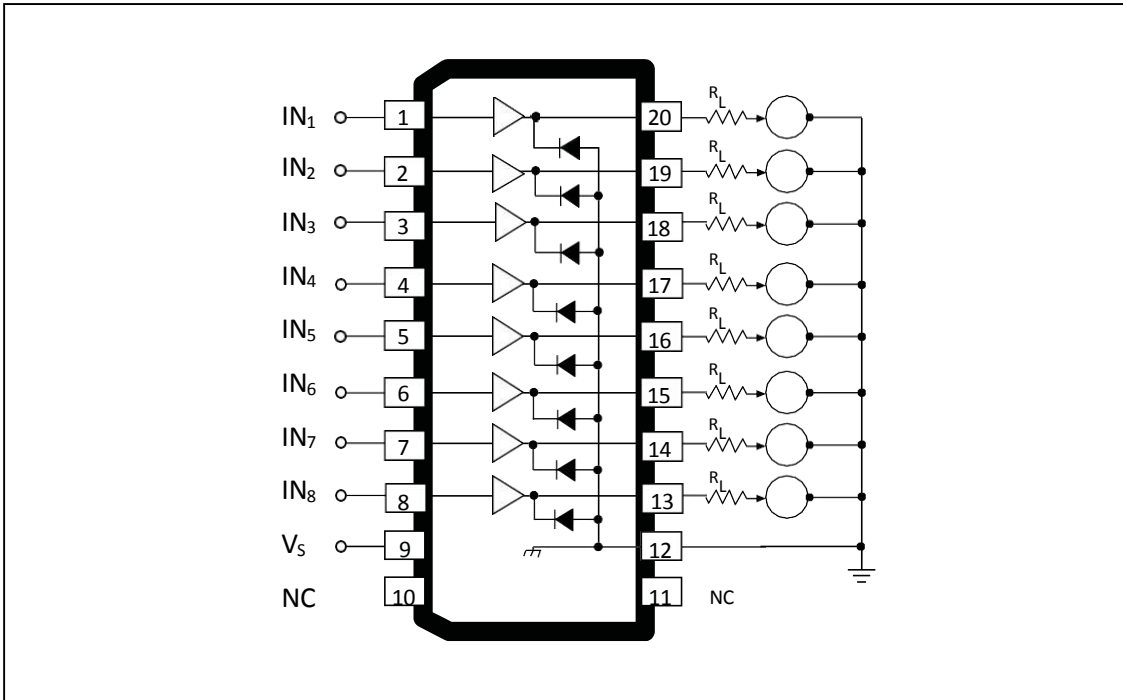

Block Diagram

Pins 10 and 11 can float; other pins match discontinued 18-pin SOP: 1 to 9 same, pins 12 to 20 match pins 10 to 18

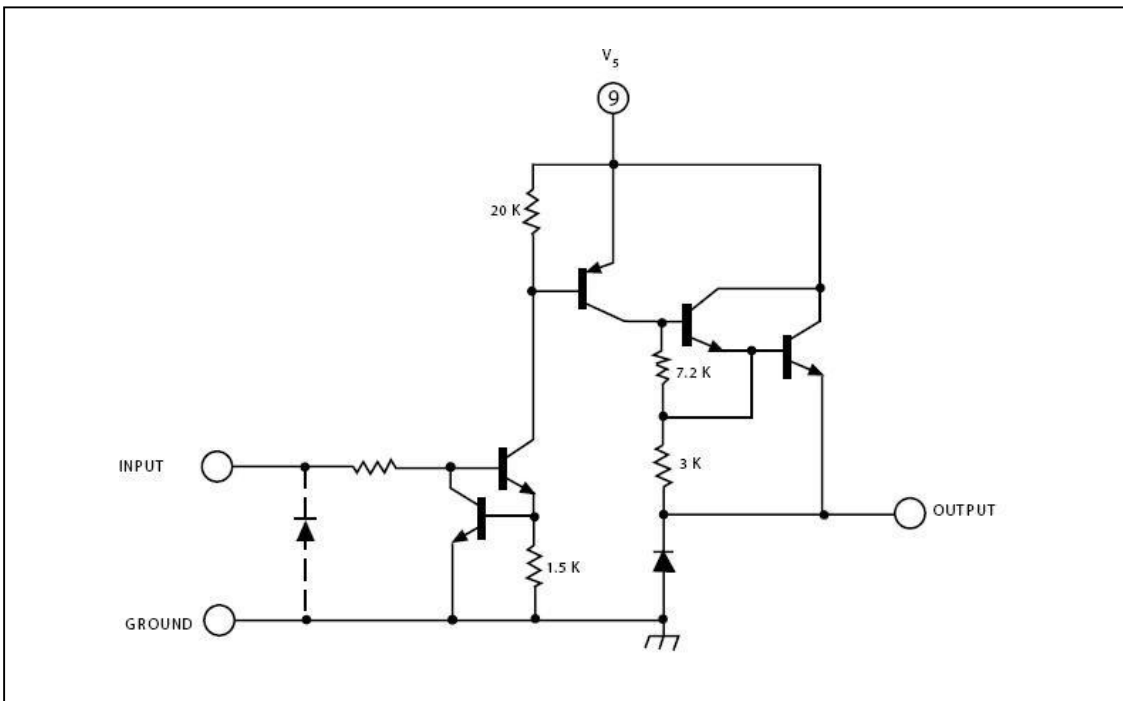

Typical electrosensitive printer application

4. SPECIFICATIONS

4.1. Absolute Maximum Ratings

Characteristic	Symbol	Notes	Rating	Units
Output Voltage Range	V_{CE}		5 to 50	V
Input Voltage	V_{IN}		20	V
Output Current	I_{OUT}		-500	mA
Package Power Dissipation	P_D	See graph	-	-
Operating Ambient Temperature	T_A	Range S	-20 to 85	°C
Maximum Junction Temperature	$T_j(\max)$		150	°C
Storage Temperature	T_{stg}		-55 to 150	°C

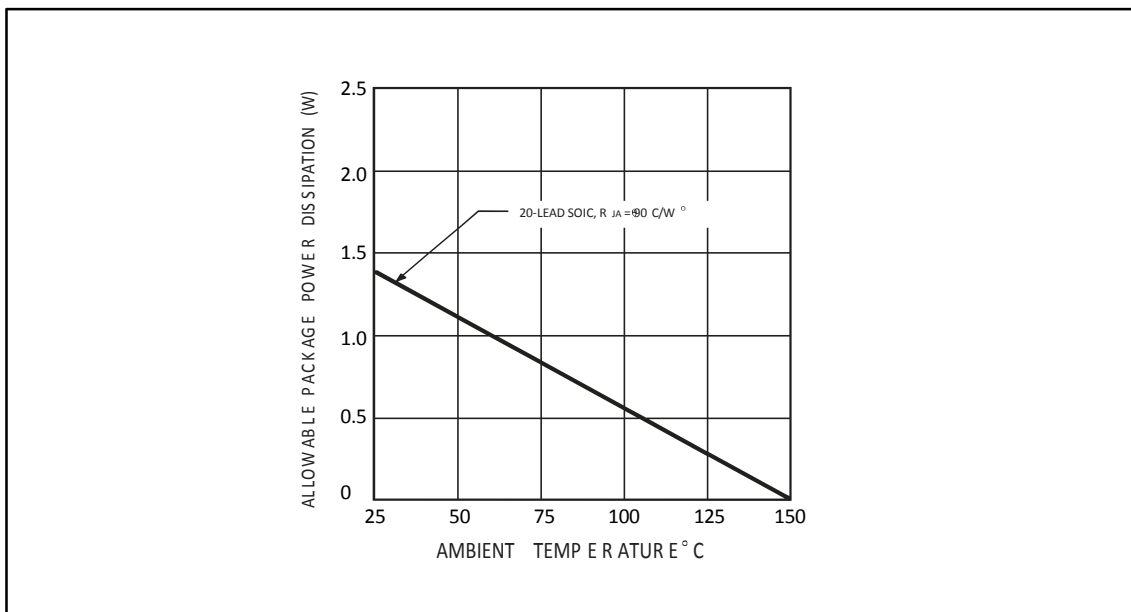

4.2. Electrical Characteristics

at $T_A = +25^\circ\text{C}$ (unless otherwise specified)

Characteristic	Symbol	Test Conditions	Test Fig.	Min.	Typ.	Max.	Units
Output Leakage Current ³	I_{CEX}	$V_{IN} = 0.4\text{ V}, V_S = 50\text{ V}$	1	—	—	20	μA
Output Sustaining Voltage	$V_{CE(SUS)}$	$I_{OUT} = -45\text{ mA}$	—	35	—	—	V
Collector-Emitter Saturation Voltage	$V_{CE(SAT)}$	$V_{IN} = 2.4\text{ V}, I_{OUT} = -100\text{ mA}$	2	—	1.6	1.8	V
		$V_{IN} = 2.4\text{ V}, I_{OUT} = -225\text{ mA}$	2	—	1.7	1.9	V
		$V_{IN} = 2.4\text{ V}, I_{OUT} = -350\text{ mA}$	2	—	1.8	2.0	V
Input Current	$I_{IN(ON)}$	$V_{IN} = 2.4\text{ V}$	3	—	140	200	μA
		$V_{IN} = 12\text{ V}$	3	—	1.25	1.93	mA
Output Source Current (Outputs Open)	I_{OUT}	$V_{IN} = 2.4\text{ V}, V_{CE} = 2.0\text{ V}$	2	-350	—	—	mA
Supply Current Leakage Current	I_S	$V_{IN} = 2.4\text{ V}^*, V_S = 50\text{ V}$	4	—	—	10	mA
Clamp Diode Current	I_R	$V_R = 50\text{ V}, V_{IN} = 0.4\text{ V}^*$	5	—	—	50	μA
Clamp Diode Forward Voltage	V_F	$I_F = 350\text{ mA}$	6	—	1.5	2.0	V
Turn-On Delay	t_{ON}	$0.5 E_{IN}$ to $0.5 E_{OUT}, R_L = 100\Omega, V_S = 35\text{ V}$	—	—	0.3	2.0	μs
Turn-Off Delay ⁴	t_{OFF}	$0.5 E_{IN}$ to $0.5 E_{OUT}, R_L = 100\Omega, V_S = 35\text{ V}$, See Note	—	—	2.0	10	μs

- [1] Negative current is defined as coming out of (sourcing) the specified device terminal.
- [2] All unused inputs must be connected to ground. Pull-down resistors (approximately 10 k Ω) are recommended for inputs that are allowed to float while power is being applied to V_S .
- [3] All inputs simultaneously.
- [4] Turn-off delay is influenced by load conditions. Systems applications well below the specified output loading may require timing considerations for some designs, i.e., multiplexed displays or when used in combination with sink drivers in a totem pole configuration.

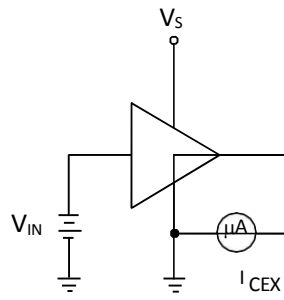

Figure 1

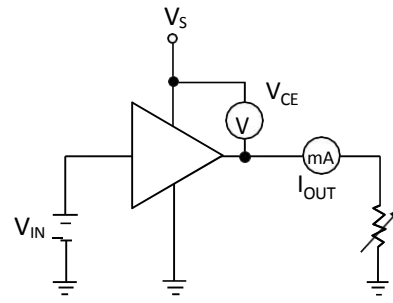

Figure 2

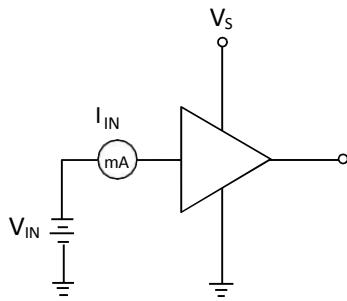

Figure 3

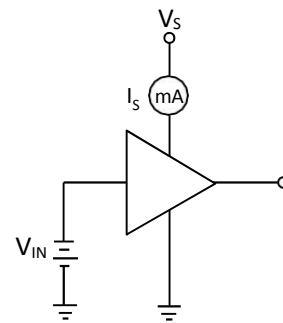

Figure 4

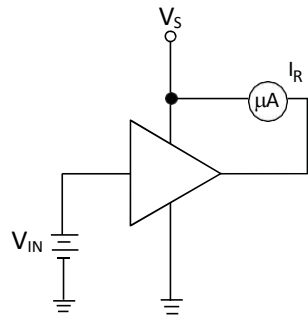

Figure 5

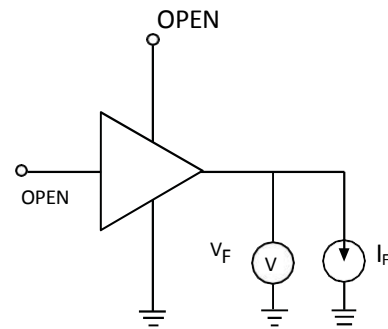
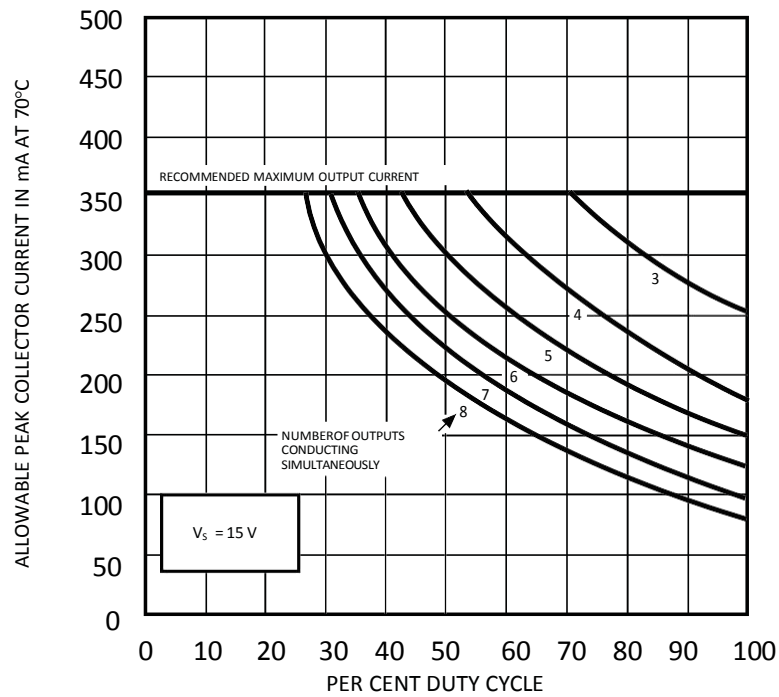
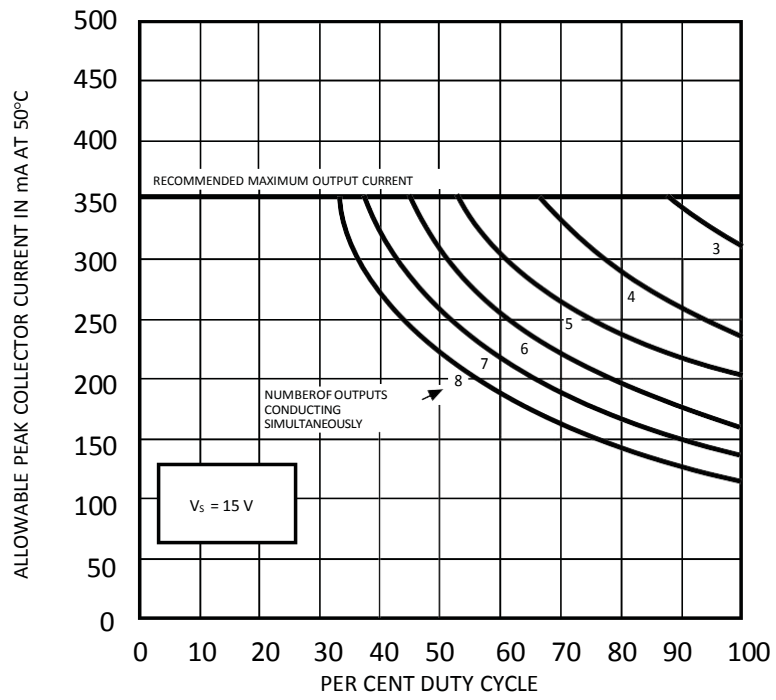
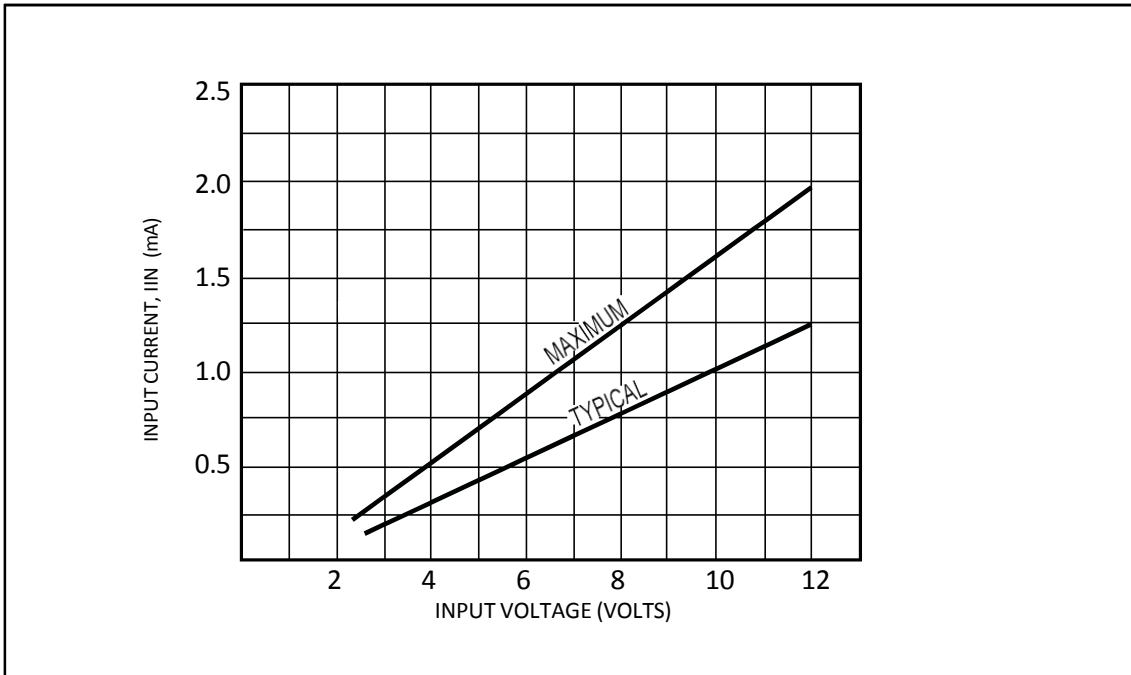

Figure 6



Allowable peak collector current as a function of duty cycle



Input current as a function of input voltage

5. ORDERING INFORMATION

Ordering Information

Part Number	Device Marking	Package Type	Body size (mm)	Temperature (°C)	MSL	Transport Media	Package Quantity
XL2982SL	XL2982SL	SOP20	12.90 * 7.50	- 25 to 85	MSL3	T&R	1000

6. DIMENSIONAL DRAWINGS

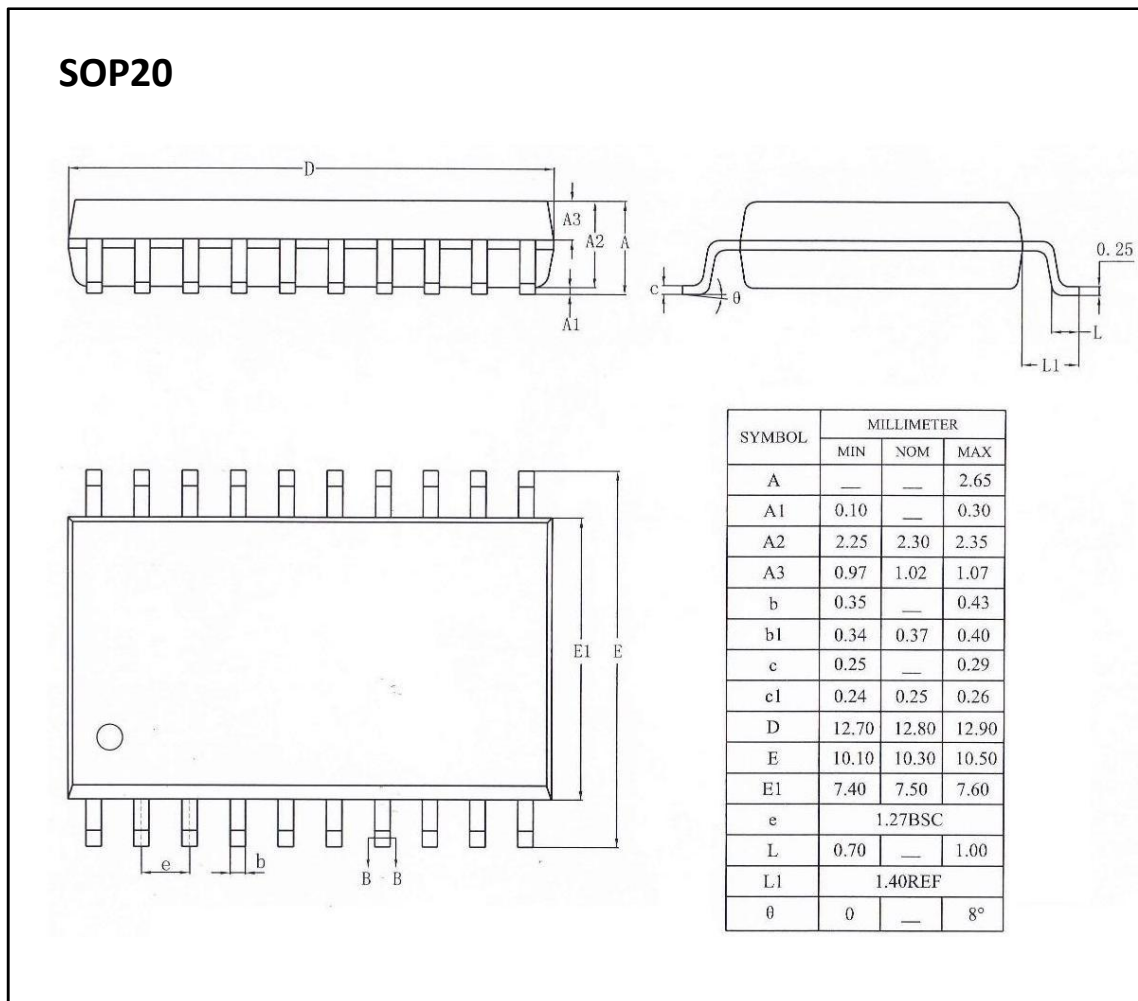

[if you need help contact us. Xinluda reserves the right to change the above information without prior notice]