

1. DESCRIPTION

The XB402U-27 is a cost efficient LED driver to drive low power LEDs. The advantages towards resistor biasing are:

- homogenous light output despite varying forward voltages in different LED strings
- homogenous light output of LEDs despite voltage drop across long supply lines
- homogenous light output independent from supply voltage variations
- longer lifetime of the LEDs due to reduced output current at higher temperatures (negative thermal coefficient)

The advantages towards discrete solutions are:

- lower assembly cost
- smaller form factor
- higher reliability due to less soldering joints
- higher output current accuracy due to pretested LED drivers

Dimming is possible by using an external digital transistor at the ground pin.

The XB402U-27 can be operated at higher supply voltages by putting LEDs between the supply voltage V_s and the power supply pin of the LED driver. You can find further details in our application notes.

The XB402U-27 is a perfect fit for numerous low power LED applications by combining small form factor with low cost. These LED drivers offer several advantages to resistors like significantly higher current control at very low voltage drop ensuring high lifetime of LEDs.

2. FEATURES

- FLED drive current preset to 20 mA
- Output current adjustable up to 65 mA with an external resistor
- Easy paralleling of drivers to increase current
- Supply voltage up to 40 V
- High current accuracy at supply voltage variation
- Low voltage overhead of 1.4 V
- Up to 750 mW power dissipation in a small SC74 package
- Negative thermal coefficient of -0.2 %/K reduces output current at higher temperatures
- RoHS compliant (Pb-free) package
- Package option: XB402U-L27 (SC74-6)

3. APPLICATION

- Channel letters for advertising, LED strips for decorative lighting
- Aircraft, train, ship illumination
- Retrofits for general lighting, white goods like refrigerator lighting
- Medical lighting
- Automotive applications like CHMSL and rear combination lights

4. PIN CONFIGURATIONS AND TYPICAL APPLICATION

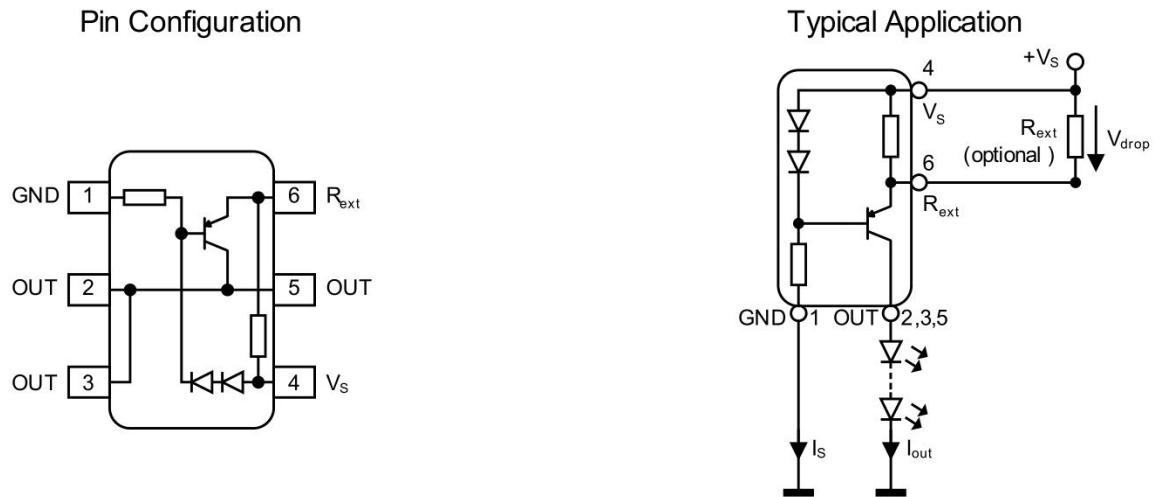

Figure 4-1 Pin configuration and typical application

5. ELECTRICAL CHARACTERISTICS

Table 5-1 Maximum Ratings at $T_A = 25\text{ }^\circ\text{C}$, unless otherwise specified

Parameter	Symbol	Values			Unit	Note / Test Condition
		Min.	Typ.	Max.		
Supply voltage	V_S	-	-	40	V	
Output current	I_{out}	-	-	65	mA	
Output voltage	V_{out}	-	-	40	V	
Reverse voltage between all terminals	V_R	-	-	0.5	V	
Total power dissipation	P_{tot}	-	-	750	mW	$T_S \leq 112.5\text{ }^\circ\text{C}$
Junction temperature	T_J	-	-	150	$^\circ\text{C}$	
Storage temperature range	T_{STG}	-40	-	85	$^\circ\text{C}$	

Attention: Stresses above the maximum values listed here may cause permanent damage to the device. Exposure to absolute maximum ratings conditions for extended periods may affect device reliability. Maximum ratings are absolute ratings; exceeding any one of these values may cause irreversible damage to the integrated circuit.

Table 5-2 Thermal Resistance at $T_A = 25\text{ }^\circ\text{C}$, unless otherwise specified

Parameter	Symbol	Values			Unit	Note / Test Condition
		Min.	Typ.	Max.		
Junction - soldering point ¹⁾	R_{thJS}	-	-	50	K/W	

1) For calculation of R_{thJA} please refer to Application Note AN077 (Thermal Resistance Calculation)

Table 5-3 Electrical Characteristics at $T_A = 25\text{ }^\circ\text{C}$, unless otherwise specified

Parameter	Symbol	Values			Unit	Note / Test Condition
		Min.	Typ.	Max.		
Collector-emitter breakdown voltage	$V_{BR(CEO)}$	40	-	-	V	$I_C = 1\text{ mA}$, $I_B = 0$
Supply current	I_S	340	420	500	μA	$V_S = 10\text{ V}$
DC current gain	h_{FE}	100	220	470	-	$I_C = 50\text{ mA}$, $V_{CE} = 1\text{ V}$
Internal resistor	R_{int}	38	44	52	Ω	$I_{Rint} = 10\text{ mA}$
Output current	I_{out}	18	20	22	mA	$V_S = 10\text{ V}$ $V_{out} = 8.6\text{ V}$
Voltage drop (V_{Rext})	V_{drop}	0.8	0.85	0.9	V	$I_{out} = 20\text{ mA}$

Table 5-4 DC Characteristics with stabilized LED load at $T_A = 25\text{ }^\circ\text{C}$, unless otherwise specified

Parameter	Symbol	Values			Unit	Note / Test Condition
		Min.	Typ.	Max.		
Lowest sufficient supply voltage overhead	V_{Smin}	-	1.4	-	V	$I_{out} > 18\text{ mA}$
Output current change versus T_A	$\Delta I_{out}/I_{out}$	-	-0.2	-	%/K	$V_S = 10\text{ V}$
Output current change versus V_S	$\Delta I_{out}/I_{out}$	-	1	-	%/V	$V_S = 10\text{ V}$

6. TYPICAL CHARACTERISTICS

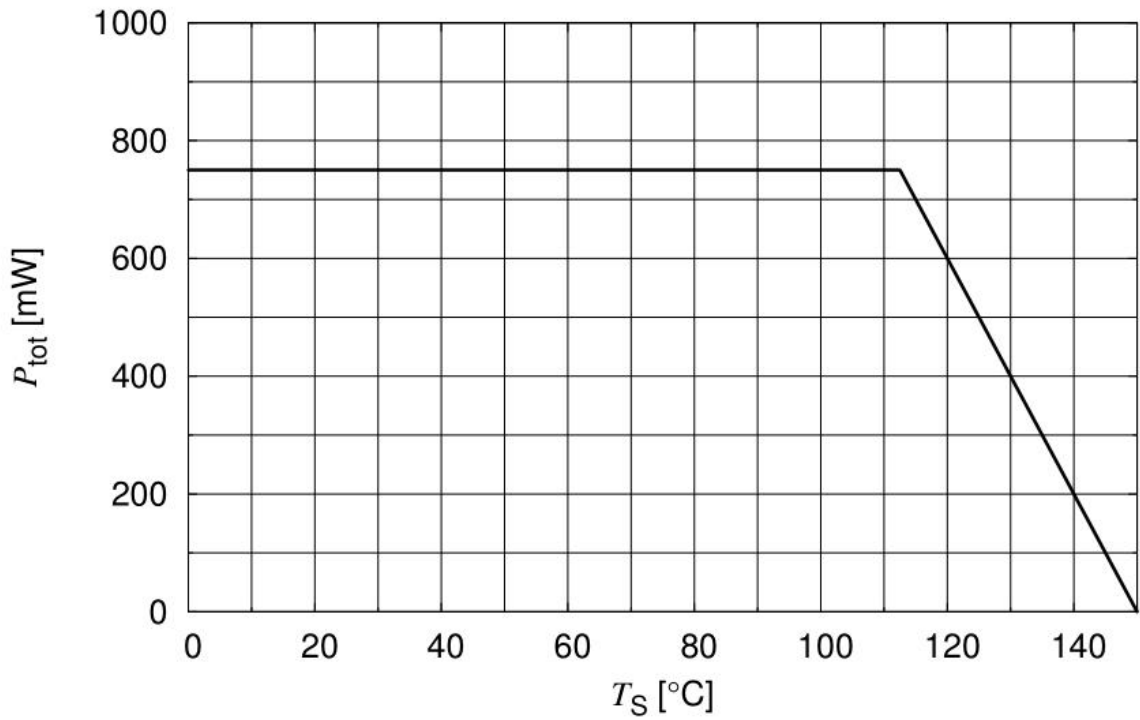

Figure 6-1 Total Power Dissipation $P_{tot} = f(T_S)$

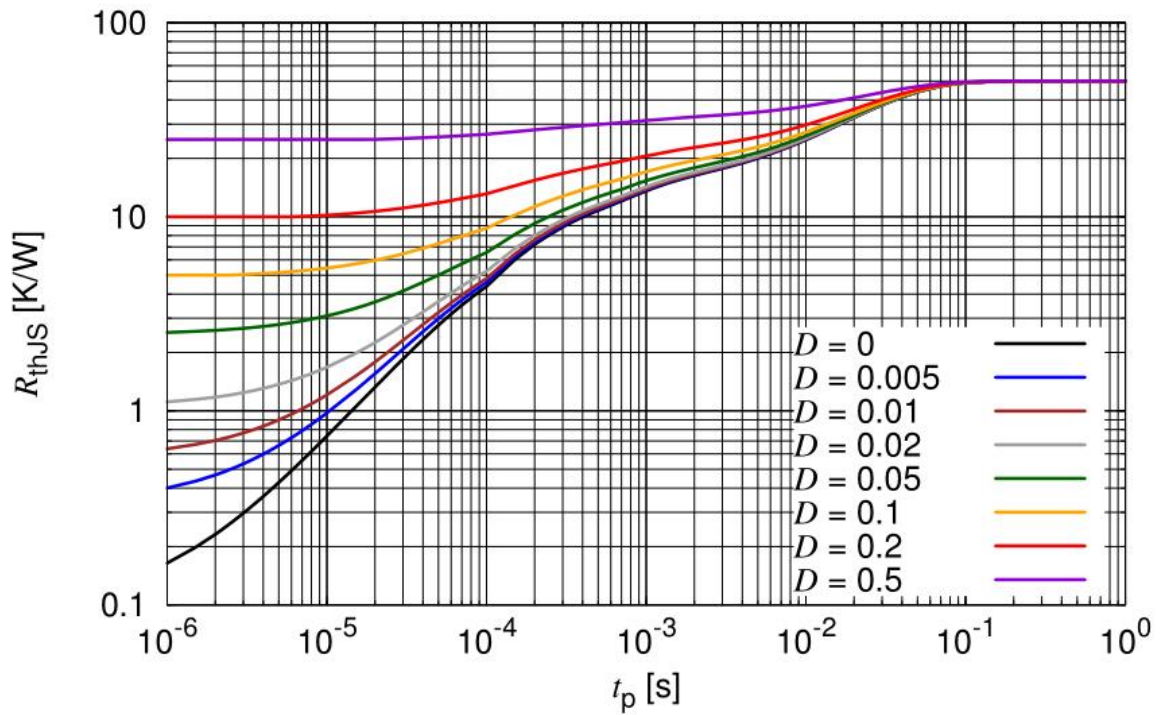

Figure 6-2 Permissible Pulse Load $R_{thJS} = f(t_p)$

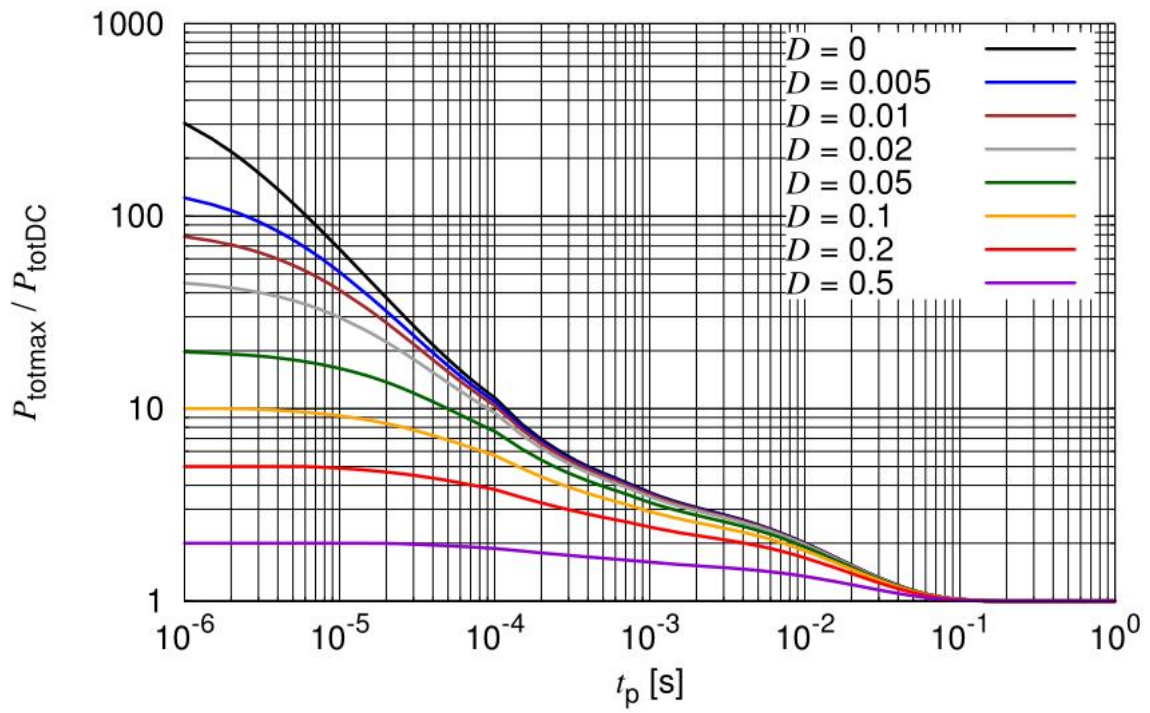

Figure 6-3 Permissible Pulse Load $P_{\text{totmax}} / P_{\text{totDC}} = f(t_p)$

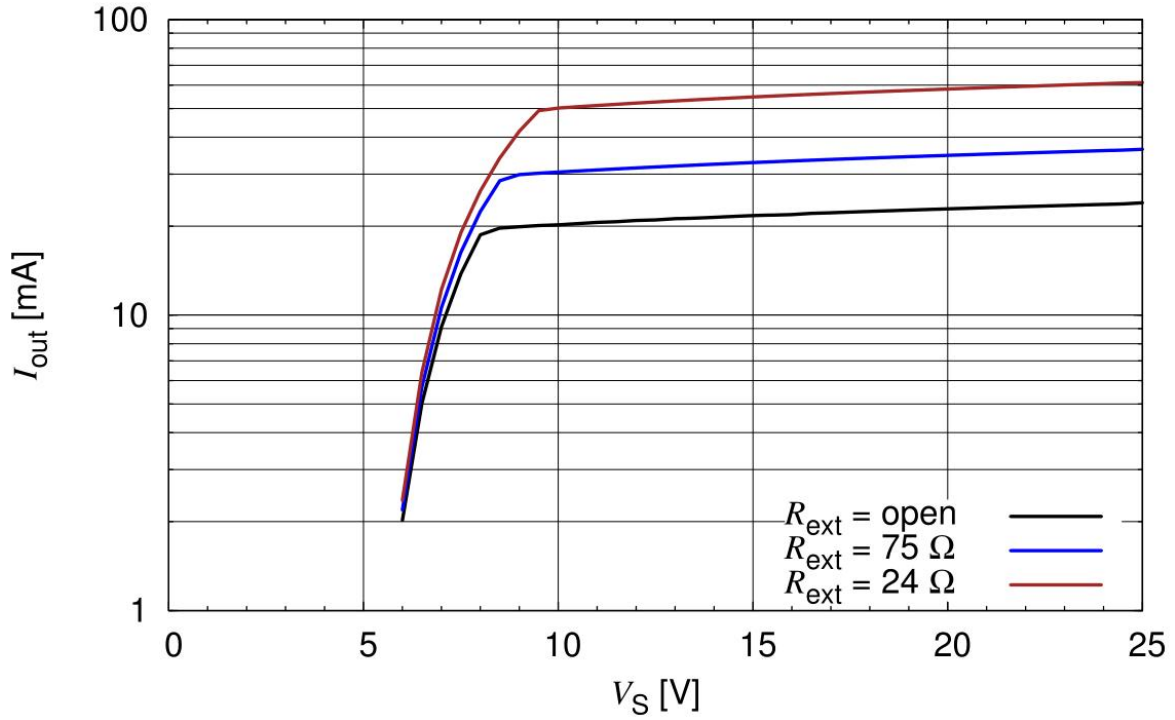

Figure 6-4 Output Current versus V_S , $I_{out} = f(V_S)$, $V_S - V_{out} = 1.4 \text{ V}$, $R_{ext} = \text{Parameter}$

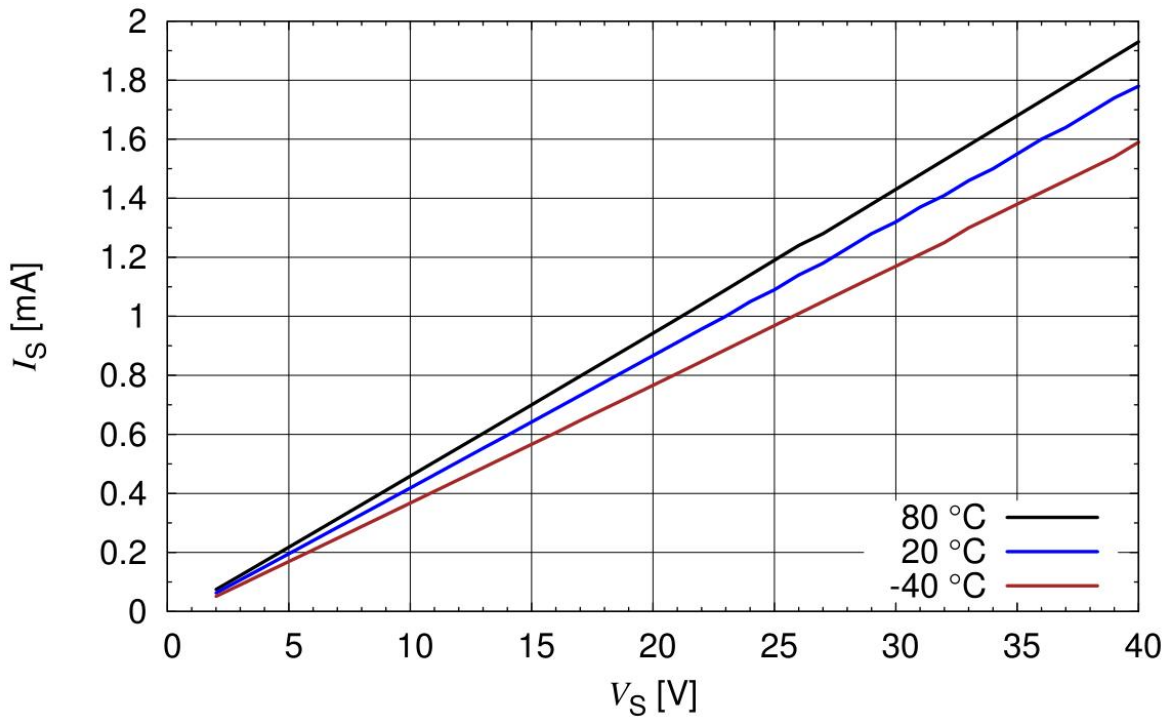

Figure 6-5 Supply Current versus V_S , $I_S = f(V_S)$, $T_A = \text{Parameter}$

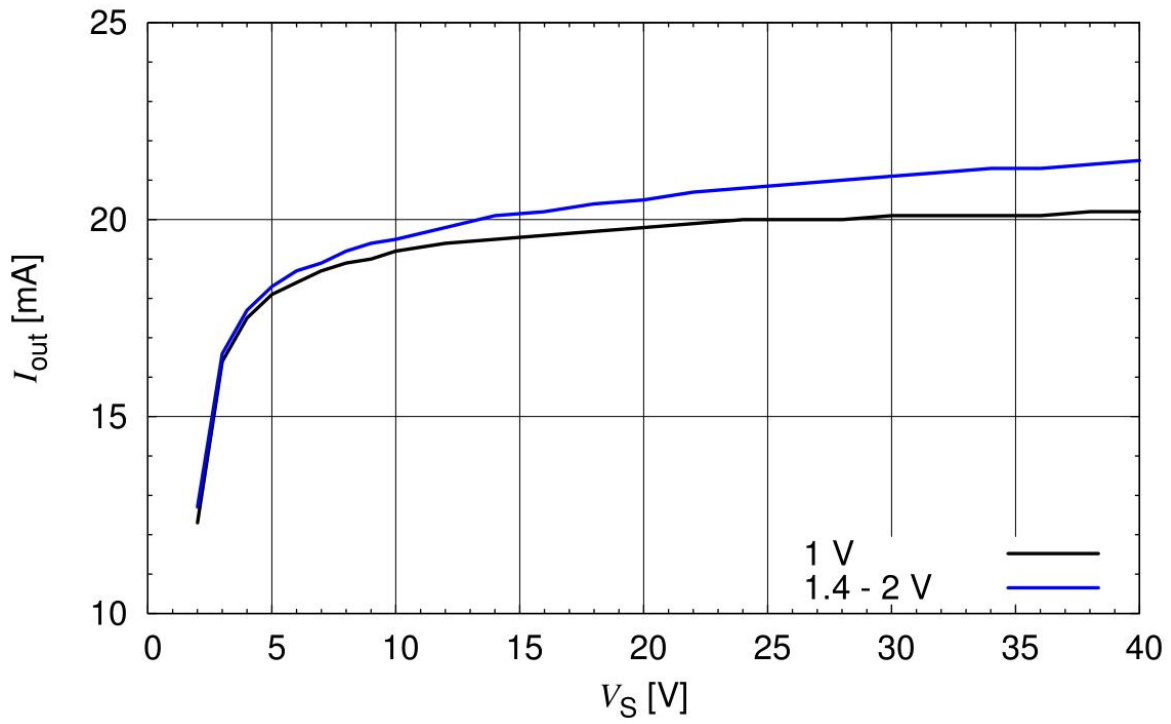

Figure 6-6 Output Current versus V_S , $I_{out} = f(V_S)$, $V_S - V_{out} = \text{Parameter}$

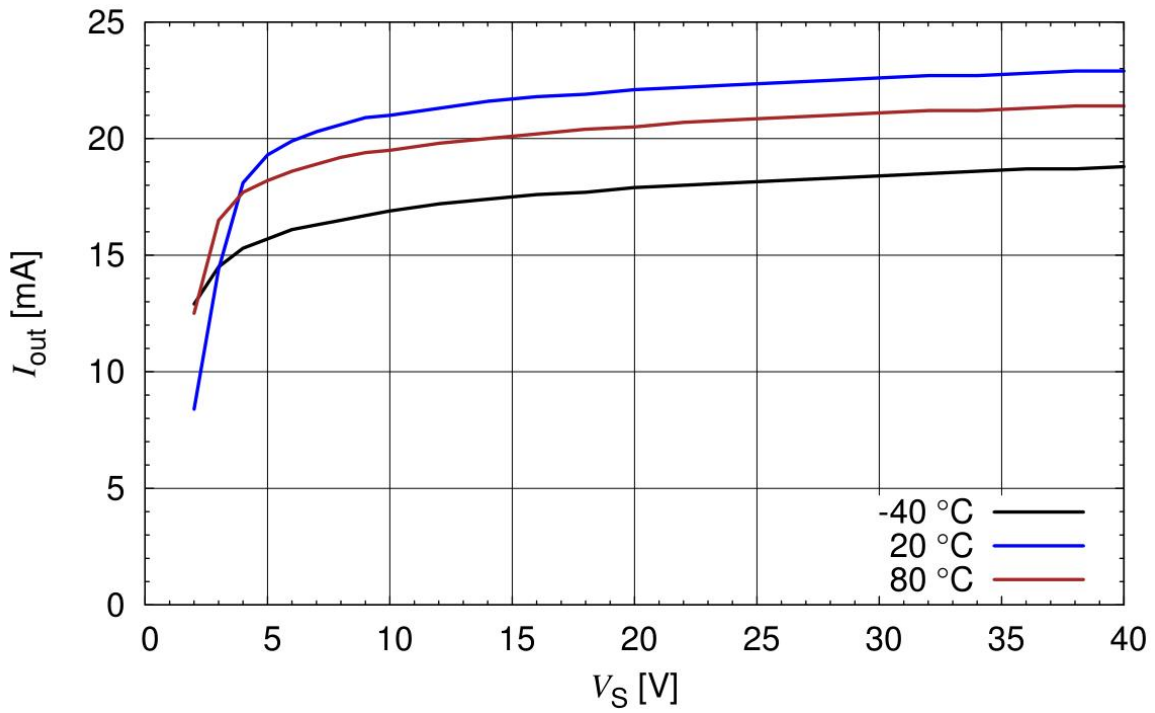

Figure 6-7 Output Current versus V_S , $I_{out} = f(V_S)$, $V_S - V_{out} = 1.4 \text{ V}$, $T_A = \text{Parameter}$

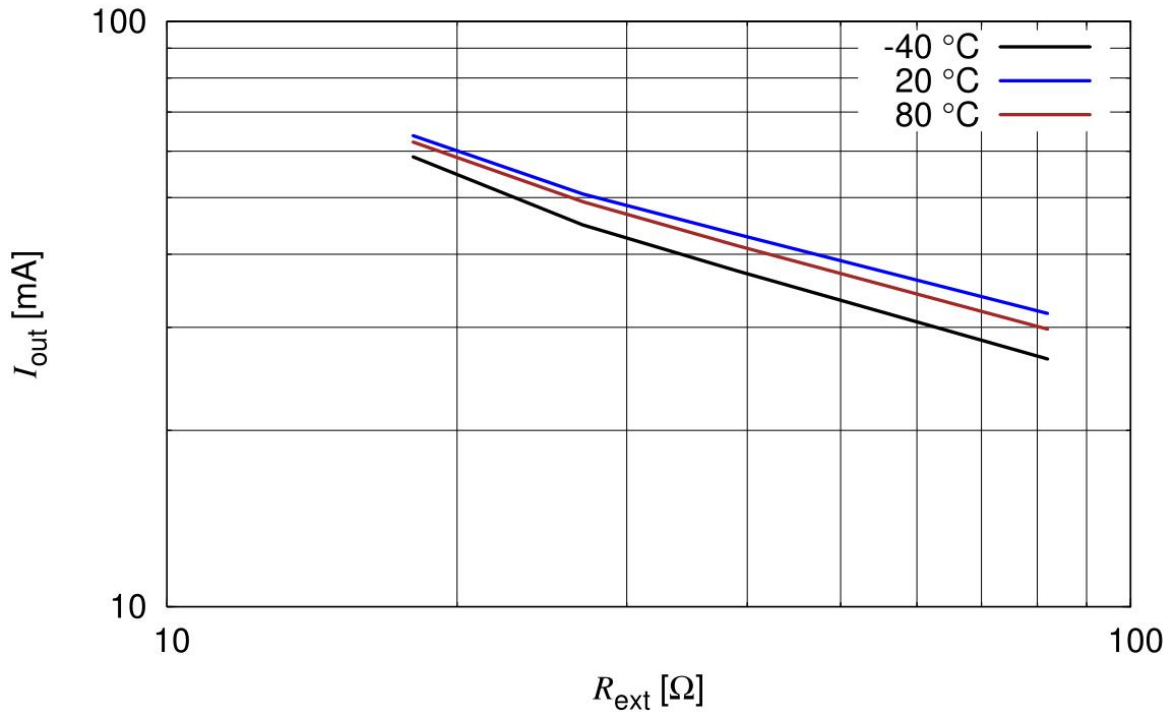

Figure 6-8 Output Current versus R_{ext} $I_{out} = f(R_{ext})$, $V_S = 10\text{ V}$, $V_S - V_{out} = 1.4\text{ V}$, $T_A = \text{Parameter}$

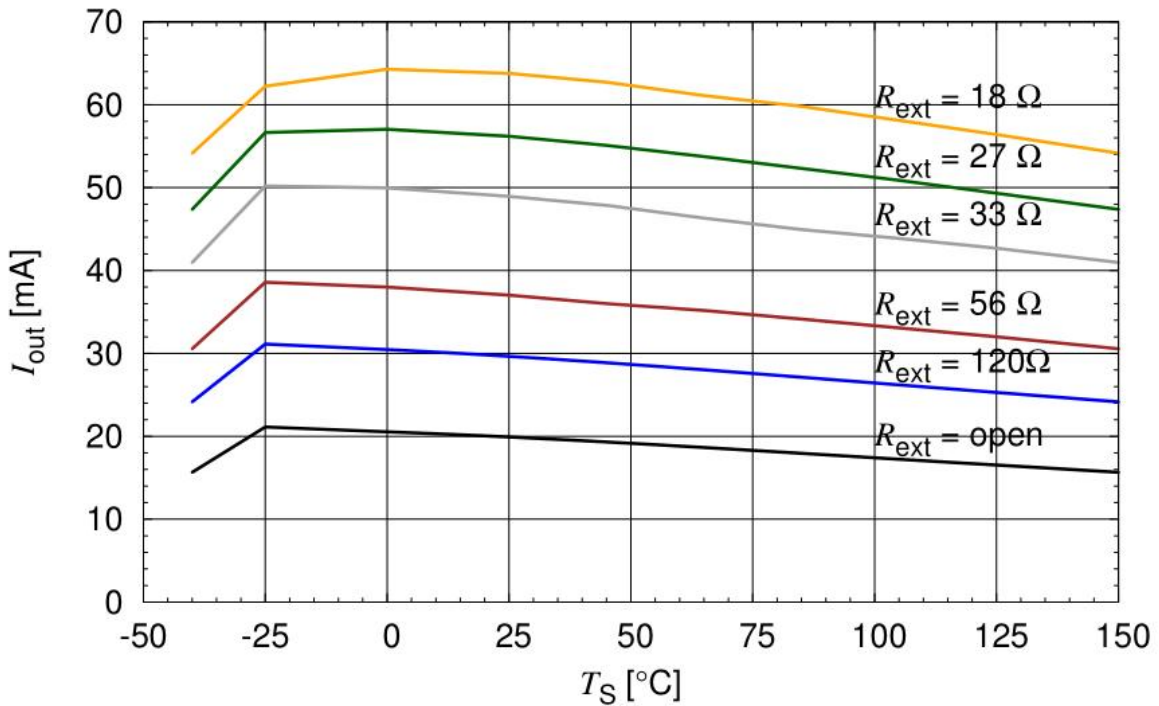

Figure 6-9 Output Current versus T_S $I_{out} = f(T_S)$, $V_S = 10\text{ V}$, $V_S - V_{out} = 1.4\text{ V}$, $R_{ext} = \text{Parameter}$

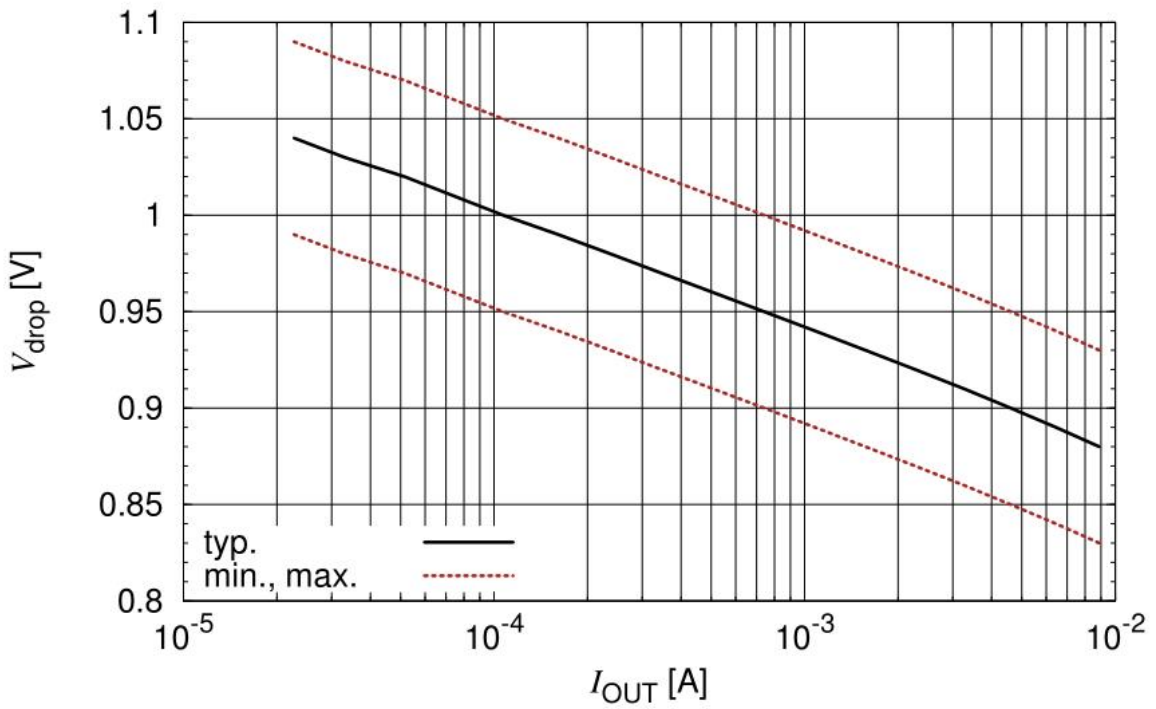

Figure 6-10 Reference Voltage V_{drop} vs I_{out} $V_{drop} = f(I_{out})$, $I_{out} = 10 \mu\text{A}$ to 10 mA

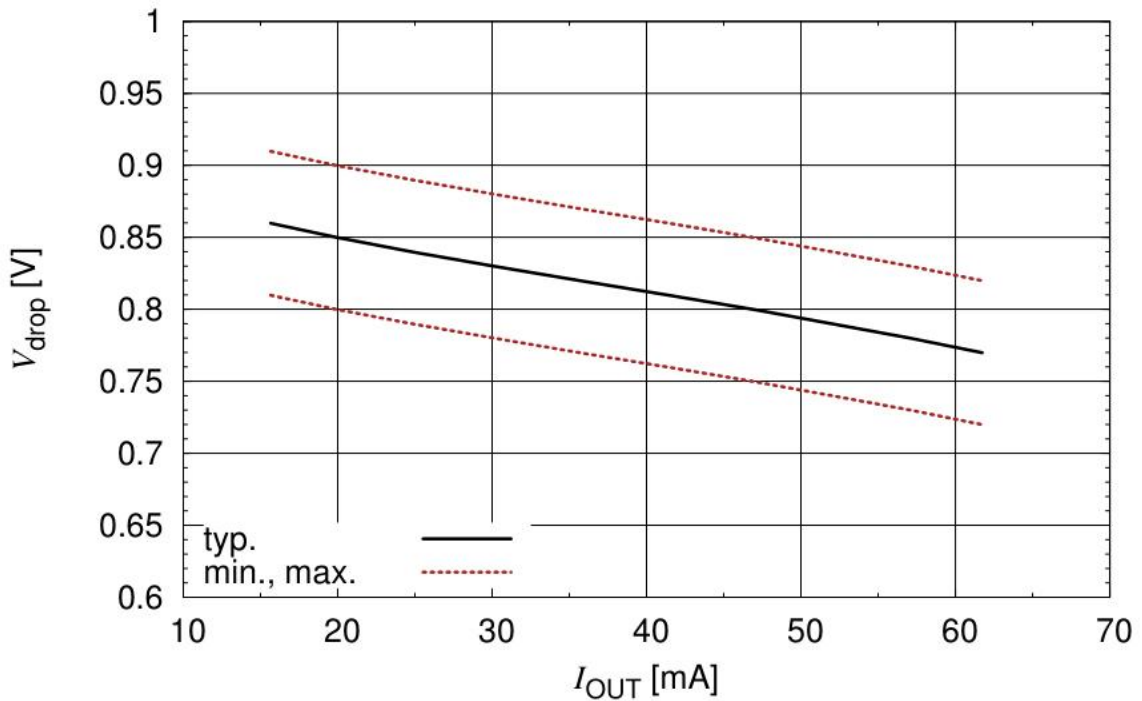

Figure 6-11 Reference Voltage V_{drop} vs I_{out} $V_{drop} = f(I_{out})$, $I_{out} = 10 \text{ mA}$ to 65 mA

7. APPLICATION HINTS

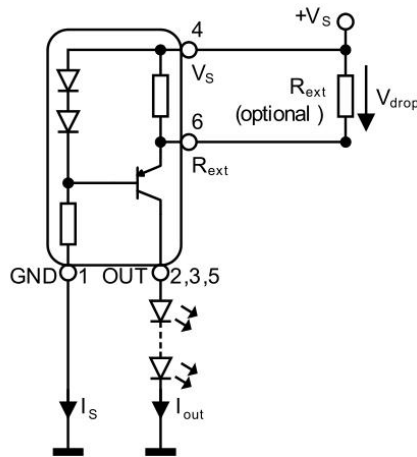

Figure 7-1 Application Circuit: Stand alone current source

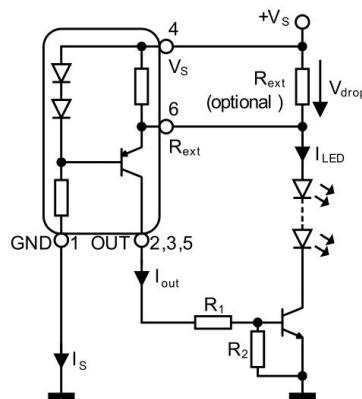

Figure 7-2 Application Circuit: Boost mode current source with external power transistor

Application hints

XB402U-L27 serves as an easy to use constant current source for LEDs. In stand alone application an external resistor R_{ext} can be connected to adjust the current between 20 mA and 65 mA. R_{ext} can be determined by using [Figure 6-8](#). Connecting a low tolerance resistor R_{ext} will improve the overall accuracy of the current sense resistance formed by the parallel connection of R_{int} and R_{ext} leading to an improved current accuracy. Please take into account that the resulting output currents will be slightly lower due to the self heating of the component and the negative thermal coefficient.

In boost mode configuration the LED current can be extended to drive high power LEDs. Please visit our website www.xinluda.com for detailed application notes.

8. ORDERING INFORMATION

Ordering Information

Part Number	Device Marking	Package Type	Body size (mm)	Temperature (°C)	MSL	Transport Media	Package Quantity
XB402U-L27	L 2 s	SC74-6	2.925 * 1.65	- 40 to 85	MSL3	T&R	3000

9. DIMENSIONAL DRAWINGS

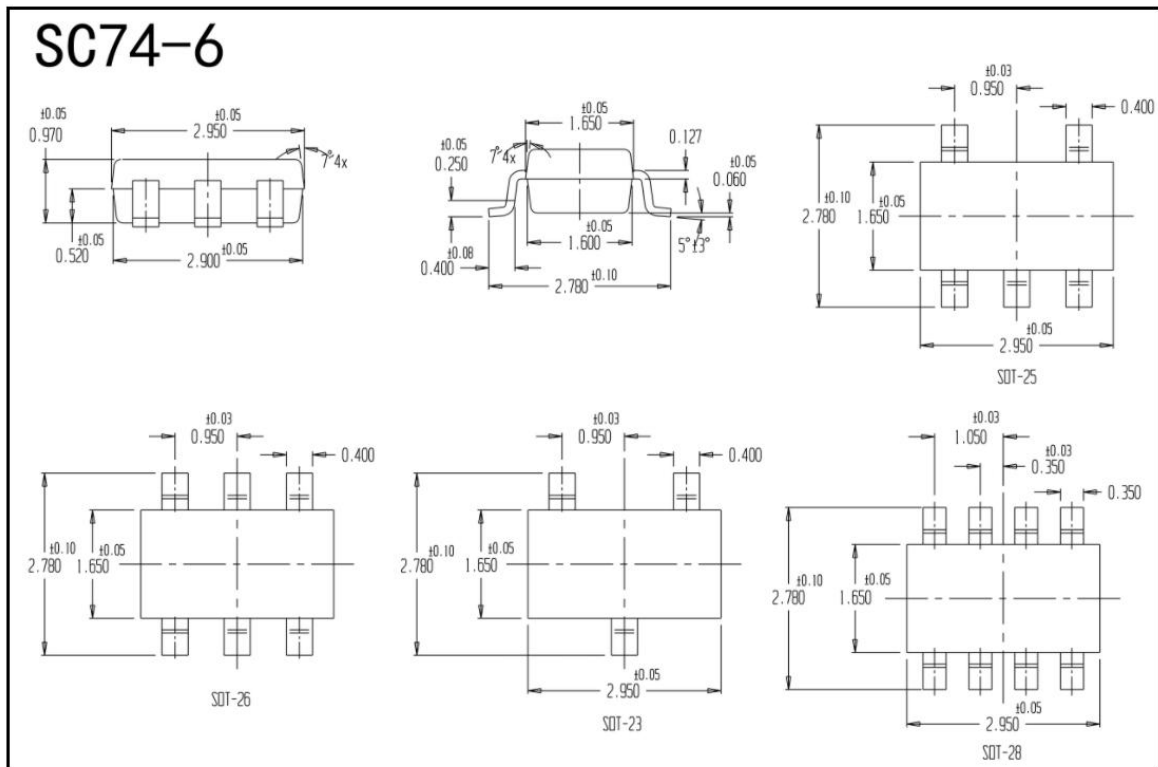

[if you need help contact us. Xinluda reserves the right to change the above information without prior notice]