

TPS2117 1.6-V to 5.5-V, 4-A Low IQ Power Mux With Manual and Priority Switchover

1 Features

- Input voltage range: 1.6 V to 5.5 V
- Maximum continuous current: 4 A
- On-resistance: 20 mΩ (typical)
- VIN2 standby current: 50 nA (typical)
- Quiescent current: 1.32 μA (typical)
- Switchover modes:
 - Priority mode
 - Manual mode
 - Diode mode
- Controlled output slew rate:
 - 1.3 ms (typical) at 3.3 V
- Reverse current blocking when VOUT > VINx
- Thermal shutdown

2 Applications

- [Backup battery system](#)
- [E-meter](#)
- [Motor drive](#)
- [Building automation](#)

3 Description

The TPS2117 is a power mux device with a voltage rating of 1.6 V to 5.5 V and a maximum current rating of 4 A. The device uses N-channel MOSFETs to switch between supplies while providing a controlled slew rate when voltage is first applied.

Due to its low quiescent of 1.32 μA (typical) and low standby current of 50 nA (typical), the TPS2117 is ideal for systems where a battery is connected to one of the inputs. These low currents extend the life and operation of the battery when in use.

The TPS2117 can be configured for two different switchover behaviors depending on the application. Automatic priority mode prioritizes the supply connected to VIN1 and switches over to the secondary supply (VIN2) when VIN1 drops. Manual mode allows the user to toggle a GPIO or enable signal to switch between channels.

Package Information

PART NUMBER	PACKAGE ⁽¹⁾	PACKAGE SIZE ⁽²⁾
TPS2117	DRL (SOT, 8)	2.10 mm × 1.60 mm

- (1) For all available packages, see the orderable addendum at the end of the data sheet.
- (2) The package size (length × width) is a nominal value and includes pins, where applicable.

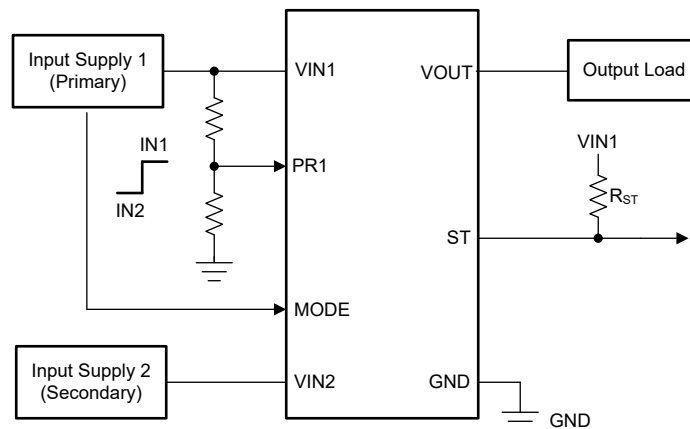

Basic Application



Table of Contents

1 Features	1	7.4 Feature Description.....	12
2 Applications	1	7.5 VINx Collapse Rate.....	14
3 Description	1	7.6 Fast Switchover Behavior.....	14
4 Revision History	2	7.7 Output Voltage Drop.....	14
5 Pin Configuration and Functions	3	8 Application and Implementation	15
6 Specifications	4	8.1 Application Information.....	15
6.1 Absolute Maximum Ratings.....	4	8.2 Typical Application.....	15
6.2 ESD Ratings.....	4	8.3 Power Supply Recommendations.....	16
6.3 Recommended Operating Conditions.....	4	8.4 Layout.....	16
6.4 Thermal Information.....	4	9 Device and Documentation Support	18
6.5 Electrical Characteristics.....	5	9.1 Documentation Support.....	18
6.6 Switching Characteristics.....	7	9.2 Receiving Notification of Documentation Updates... 18	
6.7 Timing Diagrams.....	7	9.3 Trademarks.....	18
6.8 Typical Characteristics.....	8	9.4 Electrostatic Discharge Caution.....	18
7 Detailed Description	10	9.5 Glossary.....	18
7.1 Overview.....	10	10 Mechanical, Packaging, and Orderable Information	18
7.2 Functional Block Diagram.....	10		
7.3 Device Functional Modes.....	10		

4 Revision History

NOTE: Page numbers for previous revisions may differ from page numbers in the current version.

Changes from Revision * (March 2023) to Revision A (August 2023)	Page
• Changed status from "Advance Information" to "Production Data".....	1

5 Pin Configuration and Functions

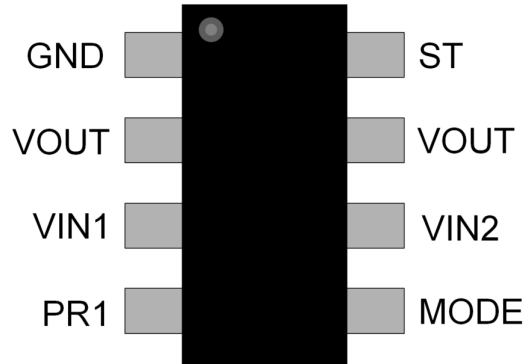

Figure 5-1. DRL Package, 8-Pin SOT (Top View)

Table 5-1. Pin Functions

PIN		I/O	DESCRIPTION
NAME	NO.		
GND	1	—	Device ground.
VOUT	2, 7	O	Output power.
VIN1	3	I	Channel 1 input power.
PR1	4	I	Selects between VIN1 and VIN2. When PR1 is high VIN1 is selected, and when PR1 is low VIN2 is selected.
MODE	5	I	Device is put into Priority mode when MODE is tied to VIN1 and manual mode when MODE is pulled up to an external voltage.
VIN2	6	I	Channel 2 input power.
ST	8	O	Open drain status pin. Pulled low when VIN1 is not being used.

6 Specifications

6.1 Absolute Maximum Ratings

over operating free-air temperature range (unless otherwise noted)⁽¹⁾

		MIN	MAX	UNIT
V_{IN1}, V_{IN2}	Input voltage	-0.3	6	V
V_{OUT}	Output voltage	-0.3	6	V
$V_{ST}, V_{PR1}, V_{MODE}$	Control pin voltage	-0.3	6	V
C_{MAX}	Maximum output capacitance, $V_{INX} = 5.5V$		1.5	mF
	Maximum output capacitance, $V_{INX} = 6V$		220	μF
I_{MAX}	Maximum current		4	A
$I_{MAX,PLS}$	Maximum pulsed current Max duration 1ms, Duty cycle of 2%		6.4	A
T_J	Junction temperature		Internally Limited	$^{\circ}C$
T_{stg}	Storage temperature	-65	150	$^{\circ}C$

- (1) Operation outside the *Absolute Maximum Ratings* may cause permanent device damage. *Absolute Maximum Ratings* do not imply functional operation of the device at these or any other conditions beyond those listed under *Recommended Operating Conditions*. If used outside the *Recommended Operating Conditions* but within the *Absolute Maximum Ratings*, the device may not be fully functional, and this may affect device reliability, functionality, performance, and shorten the device lifetime.

6.2 ESD Ratings

			VALUE	UNIT
$V_{(ESD)}$	Electrostatic discharge	Human body model (HBM), per ANSI/ESDA/ JEDEC JS-001, all pins ⁽¹⁾	± 2000	V
		Charged device model (CDM), per ANSI/ESDA/ JEDEC JS-002, all pins ⁽²⁾	± 500	

- (1) JEDEC document JEP155 states that 500-V HBM allows safe manufacturing with a standard ESD control process.
(2) JEDEC document JEP157 states that 250-V CDM allows safe manufacturing with a standard ESD control process.

6.3 Recommended Operating Conditions

over operating free-air temperature range (unless otherwise noted)

		MIN	NOM	MAX	UNIT
V_{IN1}, V_{IN2}	Input voltage	1.6		5.5	V
V_{OUT}	Output voltage	0		5.5	V
$V_{ST}, V_{MODE}, V_{PR1}$	Control pin voltage	0		5.5	V
T_A	Ambient temperature	-40		105	$^{\circ}C$

6.4 Thermal Information

	THERMAL METRIC ⁽¹⁾	TPS2117	UNIT
		DRL (SOT)	
		8-PINS	
$R_{\theta JA}$	Junction-to-ambient thermal resistance	111.7	$^{\circ}C/W$
$R_{\theta JC(top)}$	Junction-to-case (top) thermal resistance	36.4	$^{\circ}C/W$
$R_{\theta JB}$	Junction-to-board thermal resistance	18.1	$^{\circ}C/W$
Ψ_{JT}	Junction-to-top characterization parameter	1.1	$^{\circ}C/W$

6.4 Thermal Information (continued)

THERMAL METRIC ⁽¹⁾		TPS2117	UNIT
		DRL (SOT)	
		8-PINS	
Ψ_{JB}	Junction-to-board characterization parameter	17.9	°C/W

(1) For more information about traditional and new thermal metrics, see the [Semiconductor and IC Package Thermal Metrics](#) application report.

6.5 Electrical Characteristics

over operating free-air temperature range and operating voltage range of 1.6 V to 5.5 V (unless otherwise noted). Typical specifications are at an input voltage of 3.3 V and ambient temperature of 25°C.

PARAMETER		TEST CONDITIONS	T _A	MIN	TYP	MAX	UNIT
POWER CONSUMPTION							
$I_{STBY, VIN1}$	VIN1 standby current	VIN2 powers VOUT VIN1 > VIN2 + 0.1 V	25°C		1.1		μ A
			-40°C to 85°C			1.9	
			-40°C to 105°C			2	
		VIN2 powers VOUT VIN2 > VIN1 + 0.2 V	25°C		0.22		
			-40°C to 85°C			0.31	
			-40°C to 105°C			0.32	
$I_{STBY, VIN2}$	VIN2 standby current	VIN1 powers VOUT VIN2 > VIN1 + 0.2 V	25°C		1.2		μ A
			-40°C to 85°C			2	
			-40°C to 105°C			2.1	
		VIN1 powers VOUT VIN1 > VIN2 + 0.1 V	25°C		0.05		
			-40°C to 85°C			0.06	
			-40°C to 105°C			0.08	
$I_{Q, VIN1}$	VIN1 quiescent current	VIN1 powers VOUT VIN1 > VIN2 + 0.1 V	25°C		1.32		μ A
			-40°C to 85°C			3.6	
			-40°C to 105°C			4.4	
		VIN1 powers VOUT VIN2 > VIN1 + 0.2 V	25°C		0.3		
			-40°C to 85°C			0.46	
			-40°C to 105°C			0.50	
$I_{Q, VIN2}$	VIN2 quiescent current	VIN2 powers VOUT VIN2 > VIN1 + 0.2 V	25°C		1.35		μ A
			-40°C to 85°C			3.7	
			-40°C to 105°C			4.5	
		VIN2 powers VOUT VIN1 > VIN2 + 0.1 V	25°C		0.1		
			-40°C to 85°C			0.22	
			-40°C to 105°C			0.27	
$I_{SD, VIN1}$	VIN1 shutdown current	MODE = 0 V, PR1 = 5 V VIN1 > VIN2 VOUT = 0 V	25°C		0.1		μ A
			-40°C to 85°C			1.9	
			-40°C to 105°C			5.3	
		MODE = 0 V, PR1 = 5 V VIN1 < VIN2 VOUT = 0 V	25°C		0.05		
			-40°C to 85°C			1.6	
			-40°C to 105°C			4.5	

6.5 Electrical Characteristics (continued)

over operating free-air temperature range and operating voltage range of 1.6 V to 5.5 V (unless otherwise noted). Typical specifications are at an input voltage of 3.3 V and ambient temperature of 25°C.

PARAMETER		TEST CONDITIONS	T _A	MIN	TYP	MAX	UNIT	
I _{SD,VIN2}	VIN2 shutdown current	MODE = 0 V, PR1 = 5 V VIN2 > VIN1 VOUT = 0 V	25°C	0.05			μA	
			-40°C to 85°C			1.8		
			-40°C to 105°C			4.5		
		MODE = 0 V, PR1 = 5 V VIN2 < VIN1 VOUT = 0 V	25°C	0.05				
			-40°C to 85°C			1.4		
			-40°C to 105°C			3.8		
I _{REV}	Reverse leakage current out of VIN _x	V _{OUT} = 5.5 V V _{IN_x} = 0 V, V _{IN_y} = open	25°C	0.04			μA	
			85°C			0.2		
			105°C			0.5		
	Reverse leakage current into VOUT	V _{OUT} = 5.5 V V _{IN_x} = 0 V, V _{IN_y} = open	25°C	0.1				
			85°C			0.3		
			105°C			1		
I _{PR1}	PR1 pin leakage		-40°C to 105°C			0.05	μA	
I _{MODE}	MODE pin leakage		-40°C to 105°C			0.05	μA	
I _{ST}	ST pin leakage		-40°C to 105°C			0.03	μA	
PERFORMANCE								
R _{ON}	On-resistance	VIN _x = 5 V I _{OUT} = 200 mA	25°C	18.5	25		mΩ	
			-40°C to 85°C			31		
			-40°C to 105°C			33		
			VIN _x = 3.3 V I _{OUT} = 200 mA	25°C	20			26
				-40°C to 85°C				31
				-40°C to 105°C				33
		VIN _x = 1.8 V I _{OUT} = 200 mA	25°C	20.5		27		
			-40°C to 85°C			34		
			-40°C to 105°C			38		
		VIN _x = 1.6 V I _{OUT} = 200 mA	25°C	21		28		
			-40°C to 85°C			37		
			-40°C to 105°C			40		
V _{OL,ST}	Status pin V _{OL}	I _{ST} = 1 mA	-40°C to 105°C			0.1	V	
t _{ST}	Status pin response time	ST pin pulled high to low R _{ST} = 10 kΩ	-40°C to 105°C	5			μs	
V _{REF}	PR1 reference voltage		-40°C to 105°C	0.92	1	1.08	V	
V _{IH,MODE}	MODE logic high level		-40°C to 105°C	1		5.5	V	
V _{IL,MODE}	MODE logic low level		-40°C to 105°C	0		0.35	V	
PROTECTION								
V _{HYST}	VIN1/VIN2 comparator hysteresis	Diode Mode	-40°C to 105°C	60			mV	
t _{RCB}	Reverse current blocking response time	VOUT > selected VIN + 1 V	-40°C to 105°C	2			μs	
V _{RCB,R}	Reverse current blocking rising threshold (V _{OUT} - V _{IN})		-40°C to 105°C	42	70		mV	
V _{RCB,F}	Reverse current blocking falling threshold (V _{OUT} - V _{IN})		-40°C to 105°C	17	40		mV	
I _{RCB}	Reverse current blocking activation current		-40°C to 105°C	1.4	4		A	

6.5 Electrical Characteristics (continued)

over operating free-air temperature range and operating voltage range of 1.6 V to 5.5 V (unless otherwise noted). Typical specifications are at an input voltage of 3.3 V and ambient temperature of 25°C.

PARAMETER		TEST CONDITIONS	T _A	MIN	TYP	MAX	UNIT
TSD	Thermal shutdown	VIN1 = VIN2			170		°C
TSD _{HYS}	Thermal shutdown hysteresis	VIN1 = VIN2			20		°C

6.6 Switching Characteristics

Typical switching characteristics are defined at an ambient temperature of 25°C

PARAMETER		TEST CONDITIONS	MIN	TYP	MAX	UNIT
SWITCHOVER						
t _{SW}	Switchover time, VINx = 5 V	R _L = 10 Ω, C _L = 10 μF		16		μs
t _{SW}	Switchover time, VINx = 3.3 V	R _L = 10 Ω, C _L = 10 μF		15		μs
t _{SW}	Switchover time, VINx = 1.8 V	R _L = 10 Ω, C _L = 10 μF		12		μs
t _D	Delay time, VINx = 5 V	R _L = 100 Ω, C _L = 10 μF		1		ms
t _D	Delay time, VINx = 3.3 V	R _L = 100 Ω, C _L = 10 μF		1.2		ms
t _D	Delay time, VINx = 1.8 V	R _L = 100 Ω, C _L = 10 μF		1.4		ms
t _{SS}	Soft-start time, VINx = 5 V	R _L = 100 Ω, C _L = 10 μF		1.7		ms
t _{SS}	Soft-start time, VINx = 3.3 V	R _L = 100 Ω, C _L = 10 μF		1.3		ms
t _{SS}	Soft-start time, VINx = 1.8 V	R _L = 100 Ω, C _L = 10 μF		0.9		ms

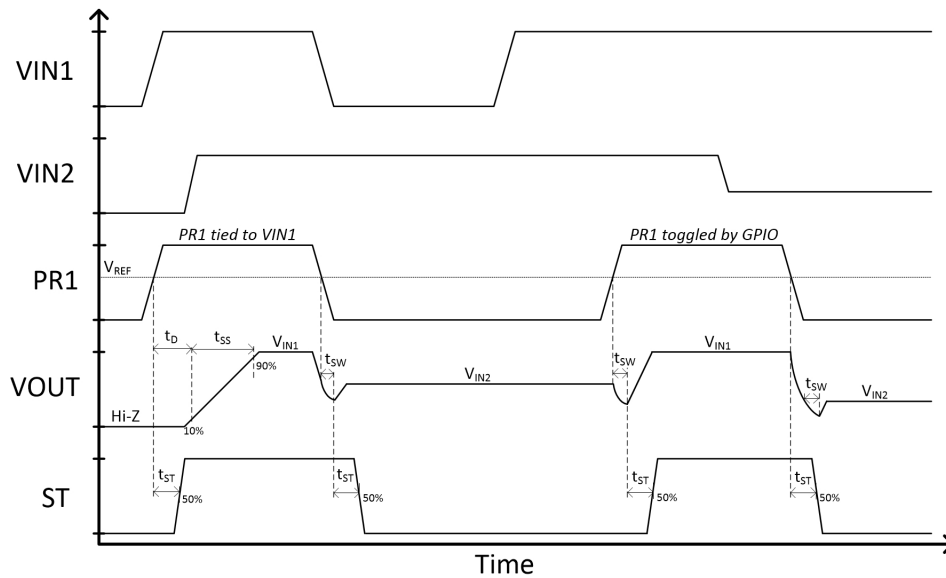

Figure 6-1. TPS2117 Timing Diagram

6.8 Typical Characteristics

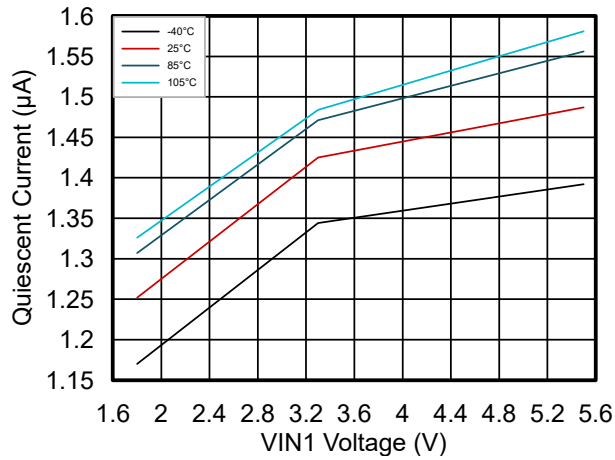

Figure 6-2. VIN1 Quiescent Current vs Input Voltage

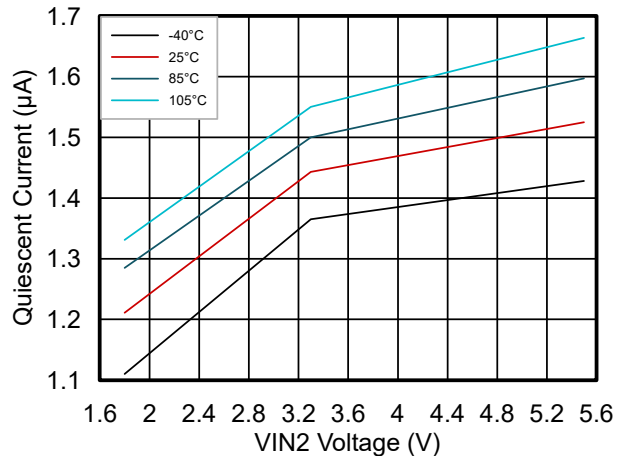

Figure 6-3. VIN2 Quiescent Current vs Input Voltage

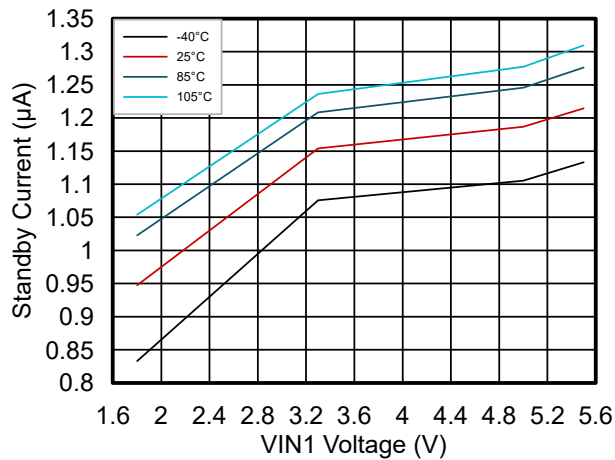

Figure 6-4. VIN1 Standby Current vs Input Voltage

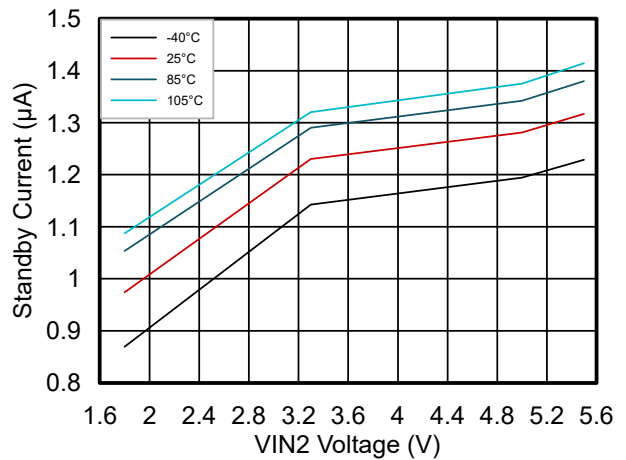

Figure 6-5. VIN2 Standby Current vs Input Voltage

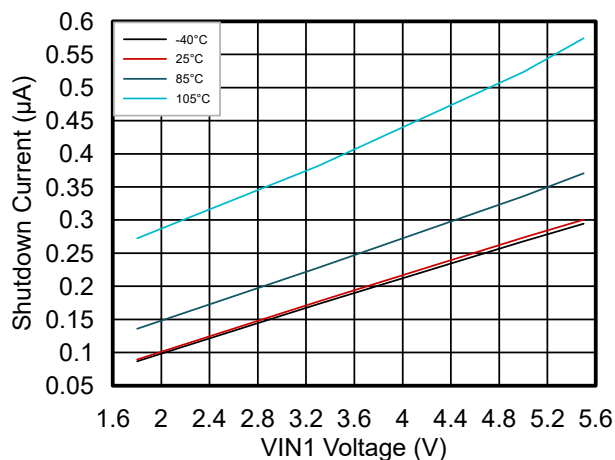

Figure 6-6. VIN1 Shutdown Current vs Input Voltage

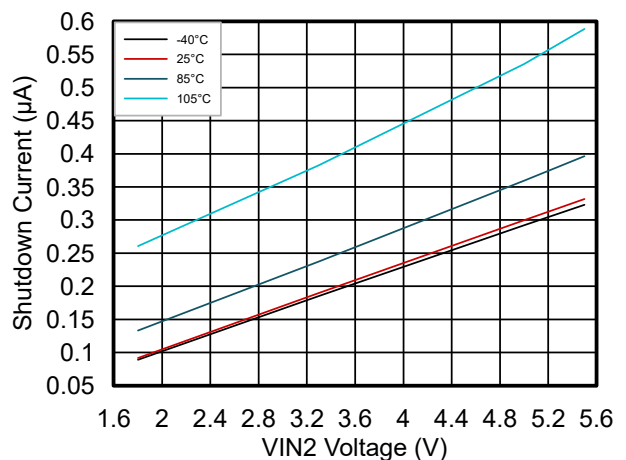
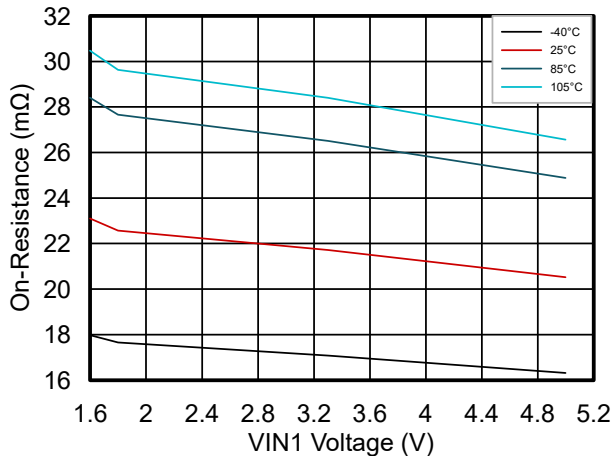

Figure 6-7. VIN2 Shutdown Current vs Input Voltage

6.8 Typical Characteristics (continued)



$I_{OUT} = 200 \text{ mA}$

Figure 6-8. Channel 1 On-Resistance vs Input Voltage

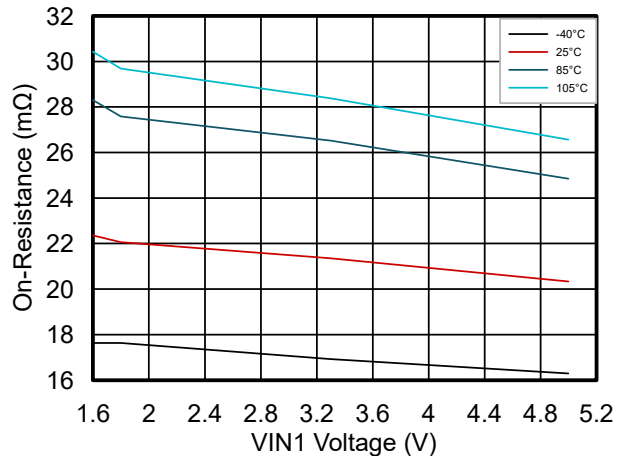

$I_{OUT} = 200 \text{ mA}$

Figure 6-9. Channel 2 On-Resistance vs Input Voltage

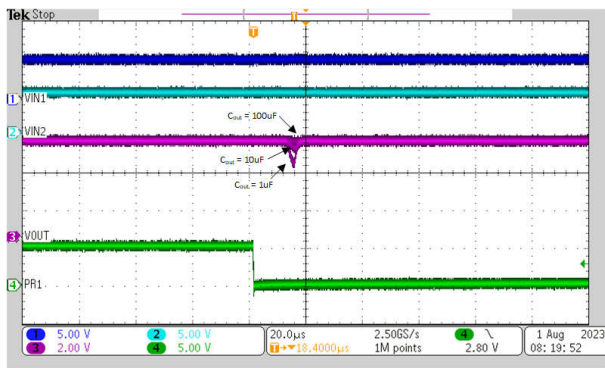

Figure 6-10. Output Voltage Drop vs Output Capacitance (MODE = $V_{IN1} = V_{IN2} = 5 \text{ V}$, $R_L = 10 \Omega$)

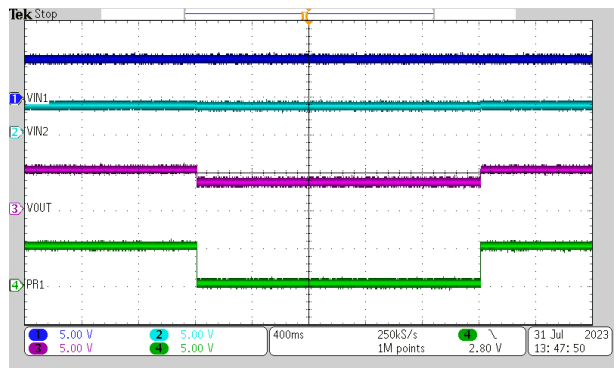

Figure 6-11. Manual Mode Switchover Behavior (MODE = $V_{IN1} = 5 \text{ V}$, $V_{IN2} = 3.3 \text{ V}$, $R_L = 10 \Omega$, $C_L = 10 \mu\text{F}$)

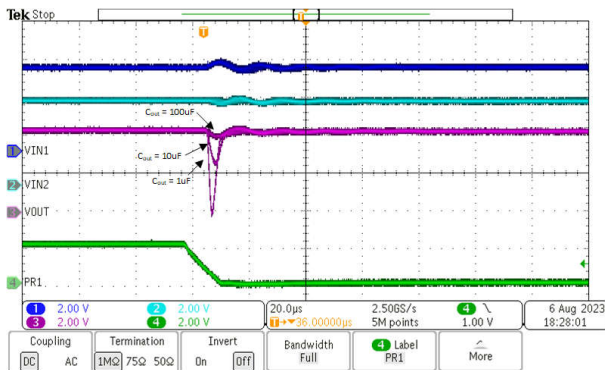

Figure 6-12. Output Voltage Drop vs Output Capacitance (MODE = $V_{IN1} = V_{IN2} = 4 \text{ V}$, $R_L = 1 \Omega$)

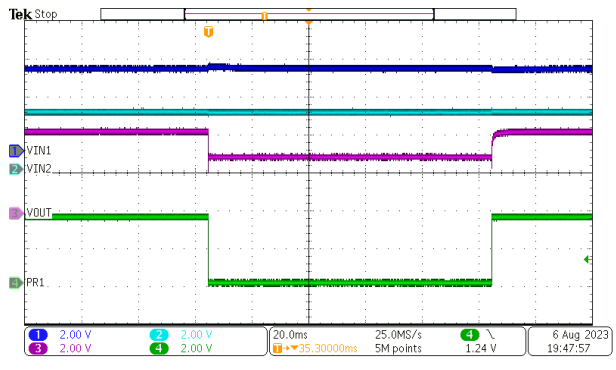

Figure 6-13. Manual Mode Switchover Behavior (MODE = $V_{IN1} = 4 \text{ V}$, $V_{IN2} = 3.3 \text{ V}$, $R_L = 1 \Omega$, $C_L = 10 \mu\text{F}$)

7 Detailed Description

7.1 Overview

The TPS2117 is a power mux device with a voltage rating of 1.6 V to 5.5 V and a maximum current rating of 4 A. The device uses N-channel MOSFETs to switch between supplies while providing a controlled slew rate when voltage is first applied.

The TPS2117 can be configured for two different switchover behaviors depending on the application. Automatic priority mode prioritizes the supply connected to VIN1 and switches over to the secondary supply (VIN2) when VIN1 drops. Manual mode allows the user to toggle a GPIO or enable signal to switch between channels.

Due to its low quiescent of 1.32 μA (typical) and standby current of 50 nA (typical), the TPS2117 is ideal for systems where a battery is connected to one of the inputs. These low currents extend the life and operation of the battery when in use.

7.2 Functional Block Diagram

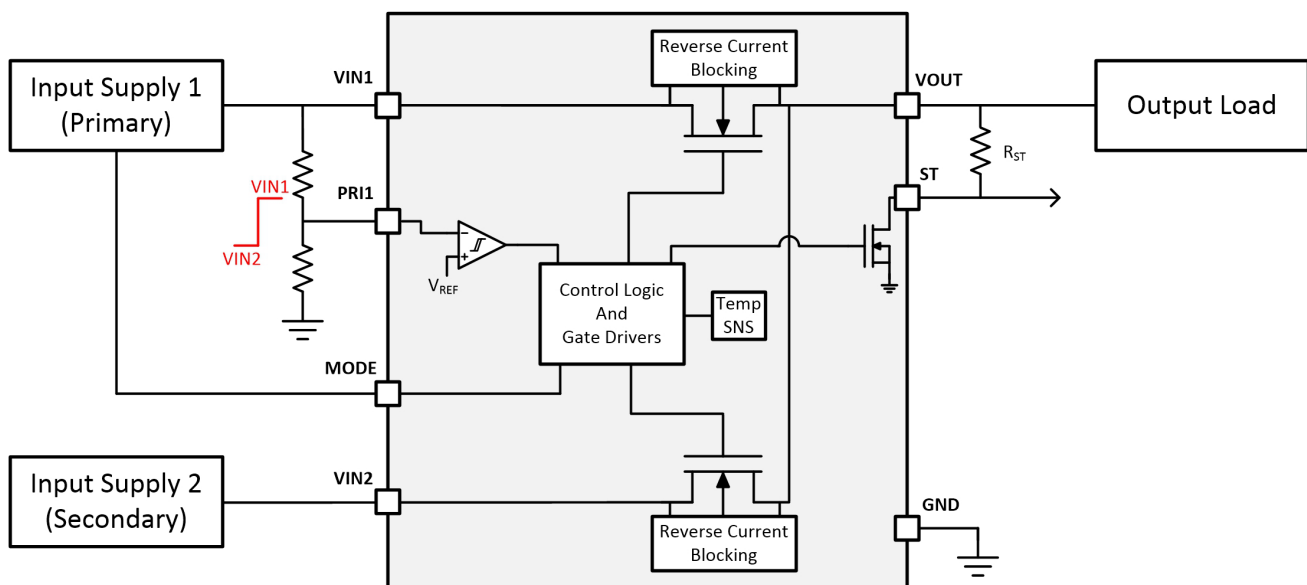

7.3 Device Functional Modes

TPS2117 can be used in many operating modes depending on the application requirements. The device will always be powered from the highest voltage rail that is connected to the VINx pins. The below sections detail the two different configuration options for the device.

7.3.1 Priority and Manual Mode

When MODE is tied high, PR1 determines the channel selected. To configure VIN1 as the priority supply, connect MODE to VIN1 and set the proper threshold through a resistor divider from VIN1 to PR1. To configure manual selection, pull up MODE to an external supply and follow the truth table ([Table 7-1](#)). When PR1 is pulled above V_{REF} , the voltage on VIN1 is used to power the output, and when it is pulled below V_{REF} , VIN2 is used to power the output. The expected behavior for the device is shown in [Figure 7-1](#).

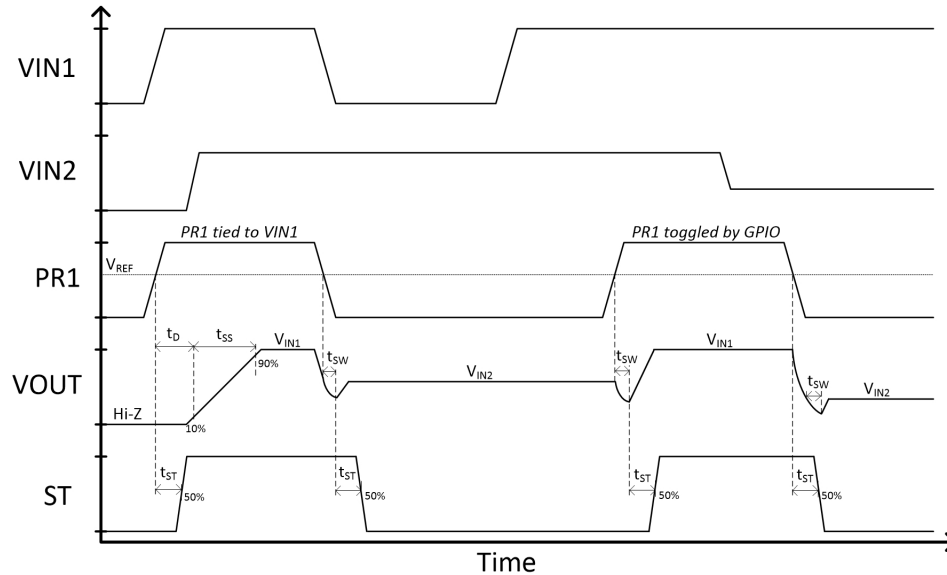

Figure 7-1. Priority and Manual Mode Switching

When PR1 is toggled, the device implements a break-before-make switchover which shuts off both channels before turning on the new channel to power the output. This means that for time t_{SW} , the output is unpowered and will dip depending on the load current and output capacitance. If the output voltage is greater than the input supply being switched to, then the device will not turn on the new channel until the output has discharged down to $V_{IN} + V_{RCB}$ to prevent reverse current flow.

When MODE is pulled low and PR1 is pulled high, the device enters shutdown. Both channels are turned off and the output is high impedance. When the PR1 pin is pulled low, the higher voltage supply between VIN1 and VIN2 is passed to the output.

7.3.1.1 Priority Switching

In the case where VIN1 takes priority over VIN2, a resistor divider can be used to set the switchover voltage threshold. When VIN1 is first applied, PR1 is brought high and VOUT is powered by that input. As VIN1 begins to drop, the voltage on PR1 is lowered until it crosses the V_{REF} threshold. At this point, the device switches over to VIN2.

7.3.1.2 Manual Switching

For applications where a GPIO pin is used to select which input passes to the output, the GPIO pin can be directly connected to the PR1 pin when MODE is tied high (≥ 1 V). When the GPIO is pulled high, VIN1 is used. When the GPIO pin is pulled low, VIN2 is used.

Manual mode can also disable both channels by pulling the MODE pin low and keeping PR1 high. In this state, the output of the device is high impedance and the leakage on each input is the shutdown current, $I_{SD,VINx}$.

7.3.2 Diode Mode

When the MODE pin is pulled below 0.35 V, the device enters a diode mode of operation. When both inputs are applied to the device, the highest voltage is used to power the output. The PR1 pin is used as an active low device enable, turning off the device when it is pulled high. When the device is turned back on, soft start is used to power the output. The expected behavior for the device is shown in Figure 7-2. It is not recommended to use diode operation for two inputs of the same voltage, that is when the device is to multiplex and to connect one input channel to the output. In the event that the input voltage sources are prone to droop in voltage when loaded, it is also recommended to use input capacitance to stabilize the rails. This can especially aid in providing stable input rails during switchover in diode mode.

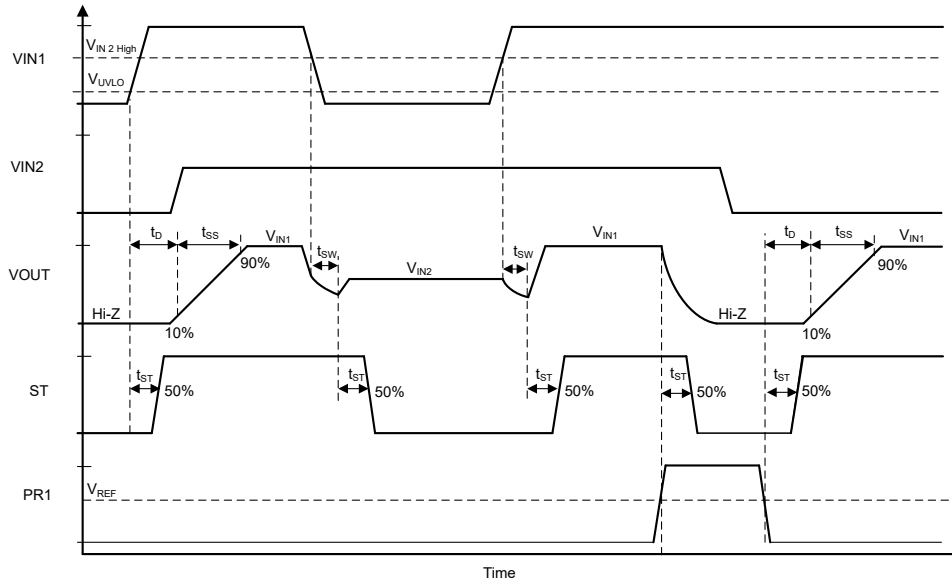

Figure 7-2. Diode Mode Switching

7.4 Feature Description

The following sections detail the features of the TPS2117.

7.4.1 Truth Table

Table 7-1 shows the expected behavior of the TPS2117. Manual mode and priority mode require MODE pin to be connected to source that is within the specification for $V_{IH,MODE}$. This can be either one of the VINx sources or an external bias. For manual mode switching, PR1 is to be controlled via an external source to select between the channels. For priority mode, PR1 voltage is set via a resistor divider from VINx sources. For diode mode, voltage on the MODE pin must be within the specification for $V_{IL,MODE}$.

Table 7-1. TPS2117 Truth Table

MODE	VIN1	VIN2	PR1	ST	VOUT
VIN1 or external bias ≥ 1 V (Priority/manual mode)	≥ 1.6 V	X ⁽¹⁾	≥ V _{REF}	High	VIN1
	≥ 1.6 V	≥ 1.6 V	< V _{REF}	Low	VIN2
	< 1.6 V	< 1.6 V	X ⁽¹⁾	Low	Hi-Z
	< 1.6 V	X ⁽¹⁾	≥ V _{REF}	Low	Hi-Z
VIN2 or external bias ≥ 1 V (Priority/manual mode)	X ⁽¹⁾	≥ 1.6 V	< V _{REF}	Low	VIN2
	≥ 1.6 V	≥ 1.6 V	≥ V _{REF}	High	VIN1
	< 1.6 V	< 1.6 V	X ⁽¹⁾	Low	Hi-Z
	X ⁽¹⁾	< 1.6 V	< V _{REF}	Low	Hi-Z
External bias ≤ 0.35 V (Diode mode)	X ⁽¹⁾	X ⁽¹⁾	≥ V _{REF}	Low	Hi-Z
	> V _{IN2} and ≥ 1.6 V	X ⁽¹⁾	< V _{REF}	High	VIN1
	X ⁽¹⁾	> V _{IN1} and ≥ 1.6 V	< V _{REF}	Low	VIN2

(1) X = do not care

7.4.2 Soft Start

When an input voltage is applied to the TPS2117 and the output voltage is lower than 1 V, the output will be brought up with soft start to minimize the inrush current due to output capacitance. However, when the device switches from one power supply to another (switchover) and V_{OUT} > 1 V, soft start is not used to minimize the output voltage drop. For linear soft start behavior, it is recommended to have an output capacitance of at least 0.1 μF.

7.4.3 Status Indication

The ST pin is an open drain output that should be pulled up to an external voltage for proper operation. When the TPS2117 is powering the output using VIN1, the ST pin will be pulled high by the external voltage source. Even if the device is blocking reverse current from V_{OUT} to VIN1, selection of VIN1 will keep the ST pin pulled high. When the TPS2117 is powering the output using VIN2 or both channels are disabled, the ST pin will be pulled low. During thermal shutdown, the ST pin will be pulled low regardless of the channel being used.

7.4.4 Reverse Current Blocking

The TPS2117 initiates reverse current blocking (RCB) when the V_{OUT} voltage is externally biased and exceeds the input voltage supply being used. Once the output voltage is higher than the input voltage by 42 mV (V_{RCB,R}), the device will shutoff. During this state, the leakage into V_{OUT} and out of VIN is defined by I_{REV}. Once the voltage difference between the output and input lowers to 17 mV (V_{RCB,F}), the channel will turn back on.

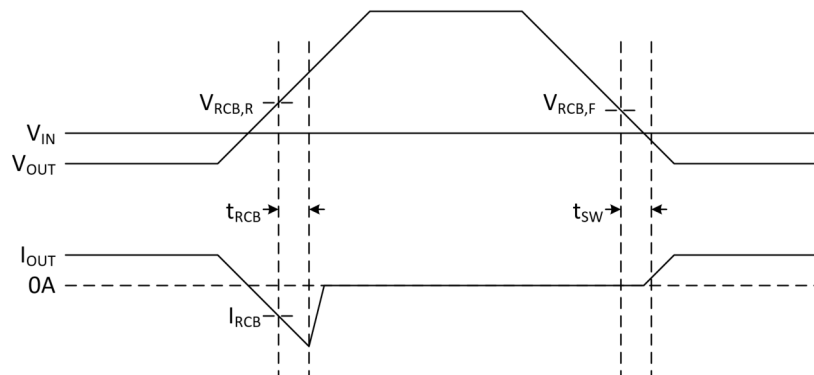

Figure 7-3. Reverse Current Blocking Behavior

If RCB is expected to occur, it is recommended to clamp the output or use a high output capacitance (about 100 μF). This will prevent voltage spikes from damaging the device due to output inductance. Reverse current is not a concern during normal switchover from one channel to another. This is because the device implements a

break-before-make switching methodology that prevents cross conduction and will not complete switchover until the output voltage is less than the chosen input voltage.

7.5 VINx Collapse Rate

The TPS2117 uses the highest voltage supply to power the device. When one supply drops below the other, the device changes the supply used to power the device. If the supply powering the device drops at a rate faster than $1 \text{ V}/10 \mu\text{s}$, the other supply must be at 2.5 V or higher to prevent the device from resetting. If the other supply is lower than 2.5 V, then the device may not be able to switch to the supply quickly enough, and the device will reset and turn on with soft start timing if $V_{\text{OUT}} < 1 \text{ V}$.

7.6 Fast Switchover Behavior

The TPS2117 transitions between a primary and secondary supply with a fast switchover time of t_{SW} . After the secondary input is connected to the output, like t_{SW} , the device heavily drives the channel of the secondary supply to ramp up the output voltage as fast as possible. This is performed to keep the driven load in a stable operating condition and to minimize the voltage dip. The duration of this channel boost is typically 11 μs . In the case of a heavy load, the output voltage may not reach the final value after 11 μs and in this case the device reverts back to the soft start output ramp rate. This behavior reduces the amount of time a large pulse of current can flow through the enabled channel and into the load.

7.7 Output Voltage Drop

The output voltage drop during switchover from one supply to another is based on the load capacitance and load resistance. The stronger the resistive load, the faster the output will discharge. The higher the capacitance on the output, the less the voltage will drop during switchover.

8 Application and Implementation

Note

Information in the following applications sections is not part of the TI component specification, and TI does not warrant its accuracy or completeness. TI's customers are responsible for determining suitability of components for their purposes, as well as validating and testing their design implementation to confirm system functionality.

8.1 Application Information

This section highlights some of the design considerations when implementing this device in various applications.

8.2 Typical Application

This typical application demonstrates how the TPS2117 device can be used to control inrush current for high output capacitances.

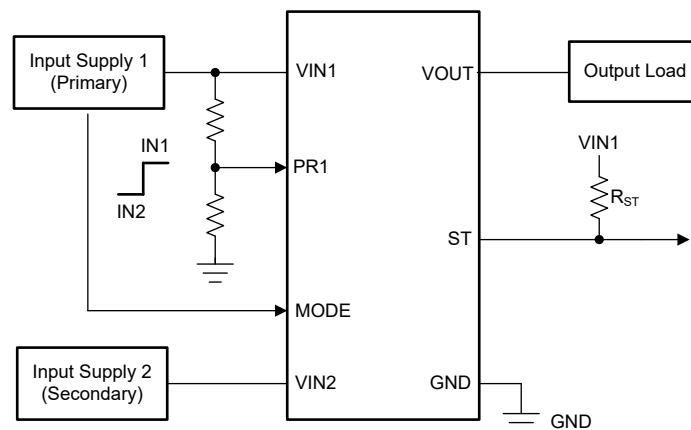

Figure 8-1. TPS2117 Typical Application Diagram

8.2.1 Design Requirements

For this example, the values below are used as the design parameters.

Table 8-1. Design Parameters

PARAMETER	VALUE
VIN1 input voltage	5 V
Mode	Priority
Output capacitance	100 μ F
Maximum inrush current	500 mA

8.2.2 Detailed Design Procedure

To determine how much inrush current is caused by the output capacitor, use [Equation 1](#).

$$I_{\text{INRUSH}} = C_{\text{OUT}} \times V_{\text{OUT}} / t_{\text{SS}} \quad (1)$$

where

- I_{INRUSH} = amount of inrush current caused by C_{OUT}
- C_{OUT} = capacitance on V_{OUT}
- t_{SS} = output voltage soft start time
- V_{OUT} = final value of the output voltage

With a final output voltage of 5 V, the expected rise time is 1.7 ms. Using the inrush current equation, the inrush current caused by a 100- μ F capacitance would be 294 mA, well below the 500-mA target.

8.2.3 Application Curves

Figure 8-2 shows 5 V being applied to VIN1. The output comes up with slew rate control and limits the inrush current to below 500 mA.

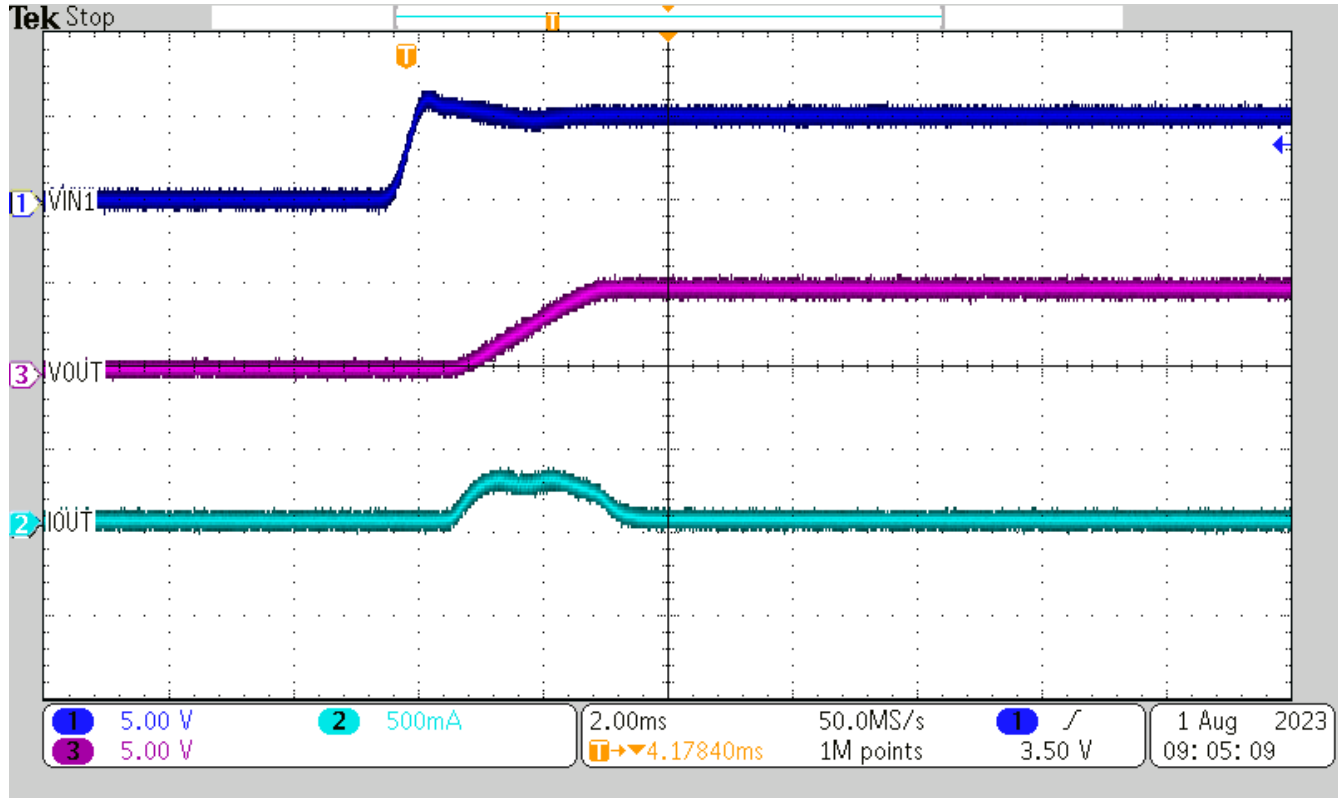

Figure 8-2. TPS2117 Inrush Current Control

8.3 Power Supply Recommendations

The device is designed to operate with a VIN range of 1.6 V to 5.5 V. The VIN power supplies must be well regulated and placed as close to the device terminals as possible. The power supplies must be able to withstand all transient load current steps. In most situations, using an input capacitance (C_{IN}) of 1 μ F is sufficient to prevent the supply voltage from dipping when the switch is turned on. In cases where the power supply is slow to respond to a large transient current or large load current step, additional bulk capacitance may be required on the input.

8.4 Layout

8.4.1 Layout Guidelines

For best performance, all traces must be as short as possible. To be most effective, the input and output capacitors must be placed close to the device to minimize the effects that parasitic trace inductances may have on normal operation. Using wide traces for VIN1, VIN2, VOUT, and GND helps minimize the parasitic electrical effects.

8.4.2 Layout Example

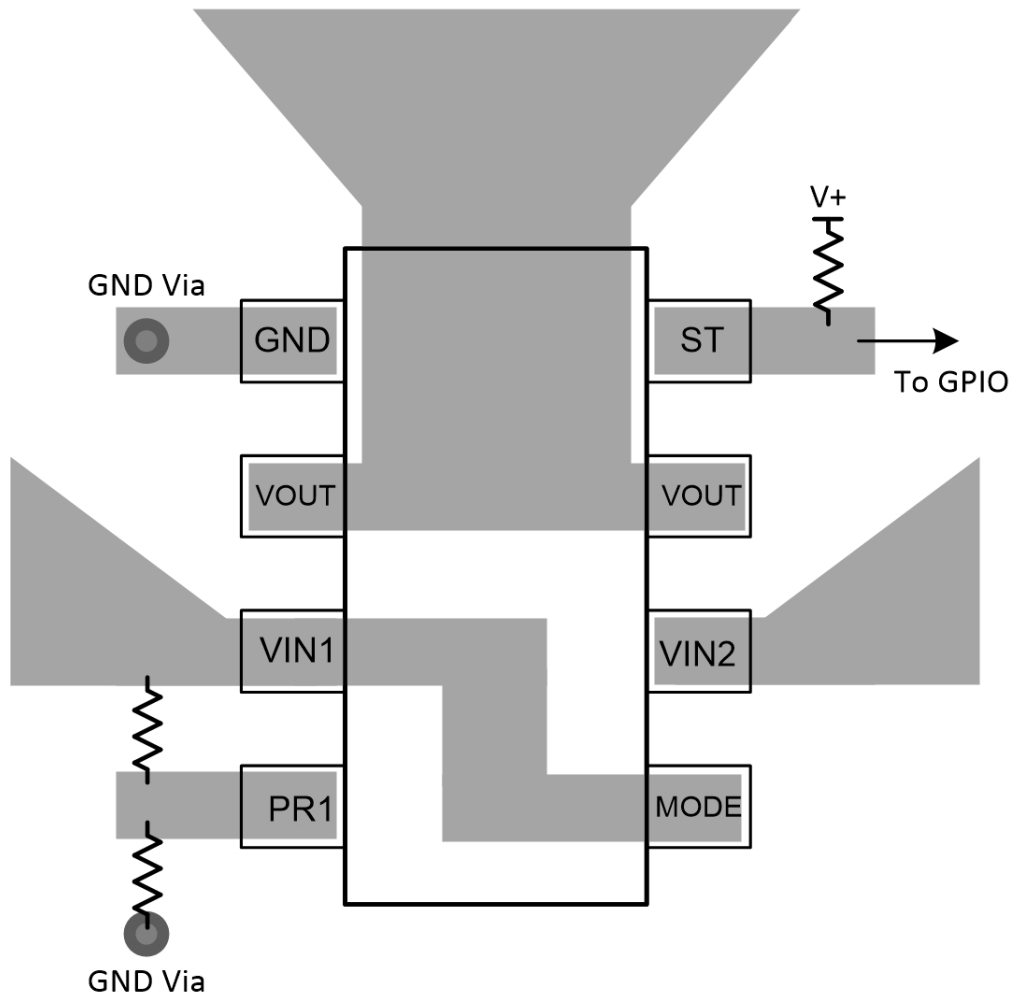

Figure 8-3. TPS2117 Layout Example

9 Device and Documentation Support

9.1 Documentation Support

9.1.1 Related Documentation

For related documentation see the following:

- [Basics of Power MUX](#)
- [11 Ways to Protect Your Power Path](#)

9.2 Receiving Notification of Documentation Updates

To receive notification of documentation updates, navigate to the device product folder on [ti.com](https://www.ti.com). Click on *Subscribe to updates* to register and receive a weekly digest of any product information that has changed. For change details, review the revision history included in any revised document.

9.3 Trademarks

All trademarks are the property of their respective owners.

9.4 Electrostatic Discharge Caution



This integrated circuit can be damaged by ESD. Texas Instruments recommends that all integrated circuits be handled with appropriate precautions. Failure to observe proper handling and installation procedures can cause damage.

ESD damage can range from subtle performance degradation to complete device failure. Precision integrated circuits may be more susceptible to damage because very small parametric changes could cause the device not to meet its published specifications.

9.5 Glossary

[TI Glossary](#) This glossary lists and explains terms, acronyms, and definitions.

10 Mechanical, Packaging, and Orderable Information

The following pages include mechanical, packaging, and orderable information. This information is the most current data available for the designated devices. This data is subject to change without notice and revision of this document. For browser-based versions of this data sheet, refer to the left-hand navigation.

PACKAGING INFORMATION

Orderable Device	Status (1)	Package Type	Package Drawing	Pins	Package Qty	Eco Plan (2)	Lead finish/ Ball material (6)	MSL Peak Temp (3)	Op Temp (°C)	Device Marking (4/5)	Samples
TPS2117DRLR	ACTIVE	SOT-5X3	DRL	8	4000	RoHS & Green	Call TI SN	Level-1-260C-UNLIM	-40 to 125	2117	Samples

(1) The marketing status values are defined as follows:

ACTIVE: Product device recommended for new designs.

LIFEBUY: TI has announced that the device will be discontinued, and a lifetime-buy period is in effect.

NRND: Not recommended for new designs. Device is in production to support existing customers, but TI does not recommend using this part in a new design.

PREVIEW: Device has been announced but is not in production. Samples may or may not be available.

OBSELETE: TI has discontinued the production of the device.

(2) **RoHS:** TI defines "RoHS" to mean semiconductor products that are compliant with the current EU RoHS requirements for all 10 RoHS substances, including the requirement that RoHS substance do not exceed 0.1% by weight in homogeneous materials. Where designed to be soldered at high temperatures, "RoHS" products are suitable for use in specified lead-free processes. TI may reference these types of products as "Pb-Free".

RoHS Exempt: TI defines "RoHS Exempt" to mean products that contain lead but are compliant with EU RoHS pursuant to a specific EU RoHS exemption.

Green: TI defines "Green" to mean the content of Chlorine (Cl) and Bromine (Br) based flame retardants meet JS709B low halogen requirements of <=1000ppm threshold. Antimony trioxide based flame retardants must also meet the <=1000ppm threshold requirement.

(3) MSL, Peak Temp. - The Moisture Sensitivity Level rating according to the JEDEC industry standard classifications, and peak solder temperature.

(4) There may be additional marking, which relates to the logo, the lot trace code information, or the environmental category on the device.

(5) Multiple Device Markings will be inside parentheses. Only one Device Marking contained in parentheses and separated by a "-" will appear on a device. If a line is indented then it is a continuation of the previous line and the two combined represent the entire Device Marking for that device.

(6) Lead finish/Ball material - Orderable Devices may have multiple material finish options. Finish options are separated by a vertical ruled line. Lead finish/Ball material values may wrap to two lines if the finish value exceeds the maximum column width.

Important Information and Disclaimer:The information provided on this page represents TI's knowledge and belief as of the date that it is provided. TI bases its knowledge and belief on information provided by third parties, and makes no representation or warranty as to the accuracy of such information. Efforts are underway to better integrate information from third parties. TI has taken and continues to take reasonable steps to provide representative and accurate information but may not have conducted destructive testing or chemical analysis on incoming materials and chemicals. TI and TI suppliers consider certain information to be proprietary, and thus CAS numbers and other limited information may not be available for release.

In no event shall TI's liability arising out of such information exceed the total purchase price of the TI part(s) at issue in this document sold by TI to Customer on an annual basis.

TAPE AND REEL INFORMATION

QUADRANT ASSIGNMENTS FOR PIN 1 ORIENTATION IN TAPE



*All dimensions are nominal

Device	Package Type	Package Drawing	Pins	SPQ	Reel Diameter (mm)	Reel Width W1 (mm)	A0 (mm)	B0 (mm)	K0 (mm)	P1 (mm)	W (mm)	Pin1 Quadrant
TPS2117DRLR	SOT-5X3	DRL	8	4000	180.0	8.4	2.75	1.9	0.8	4.0	8.0	Q3

TAPE AND REEL BOX DIMENSIONS

*All dimensions are nominal

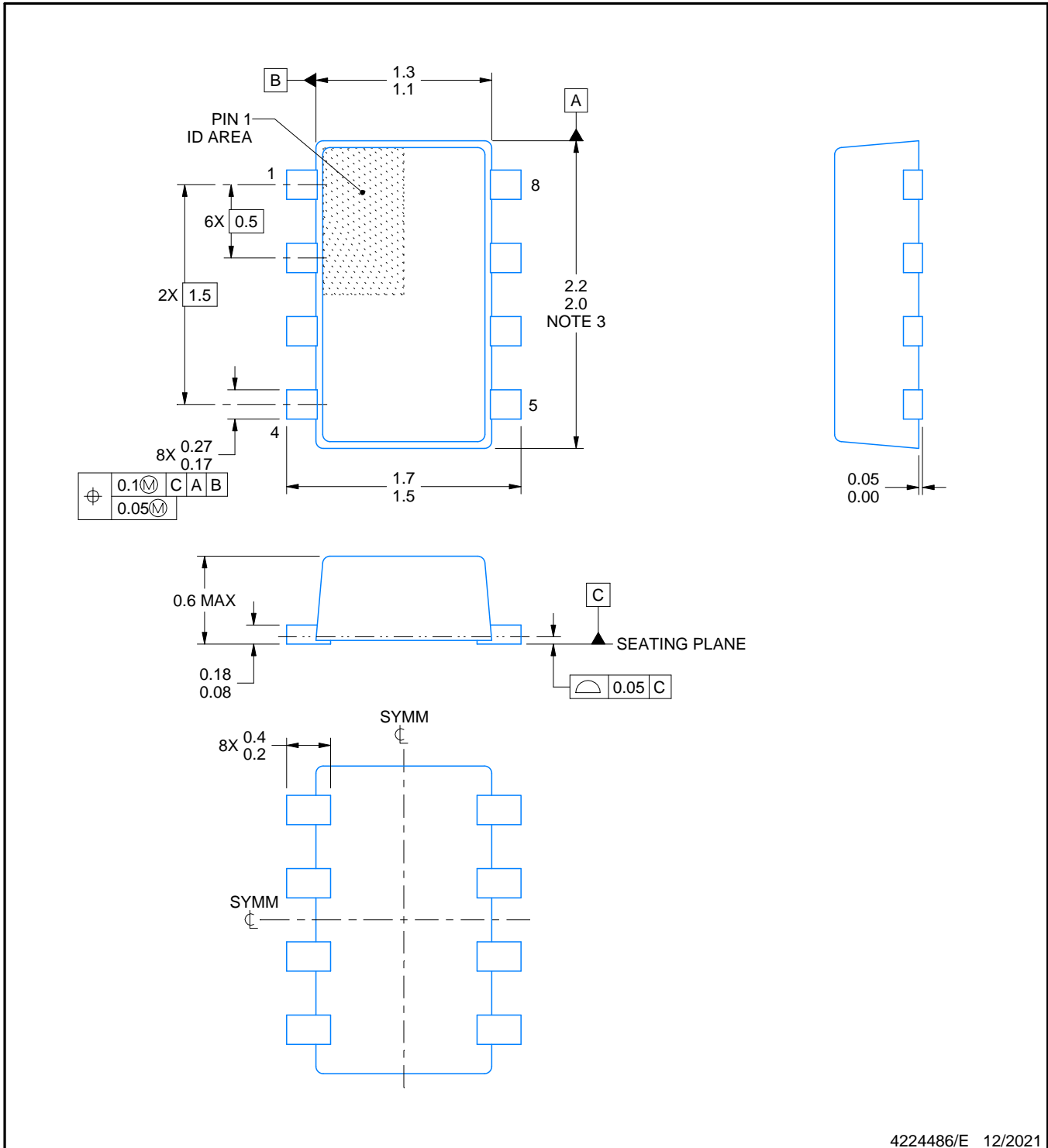
Device	Package Type	Package Drawing	Pins	SPQ	Length (mm)	Width (mm)	Height (mm)
TPS2117DRLR	SOT-5X3	DRL	8	4000	210.0	185.0	35.0



4224486/E 12/2021

NOTES:

1. All linear dimensions are in millimeters. Any dimensions in parenthesis are for reference only. Dimensioning and tolerancing per ASME Y14.5M.
2. This drawing is subject to change without notice.
3. This dimension does not include mold flash, protrusions, or gate burrs. Mold flash, interlead flash, protrusions, or gate burrs shall not exceed 0.15 mm per side.
4. Reference JEDEC Registration MO-293, Variation UDAD

EXAMPLE BOARD LAYOUT

DRL0008A

SOT-5X3 - 0.6 mm max height

PLASTIC SMALL OUTLINE

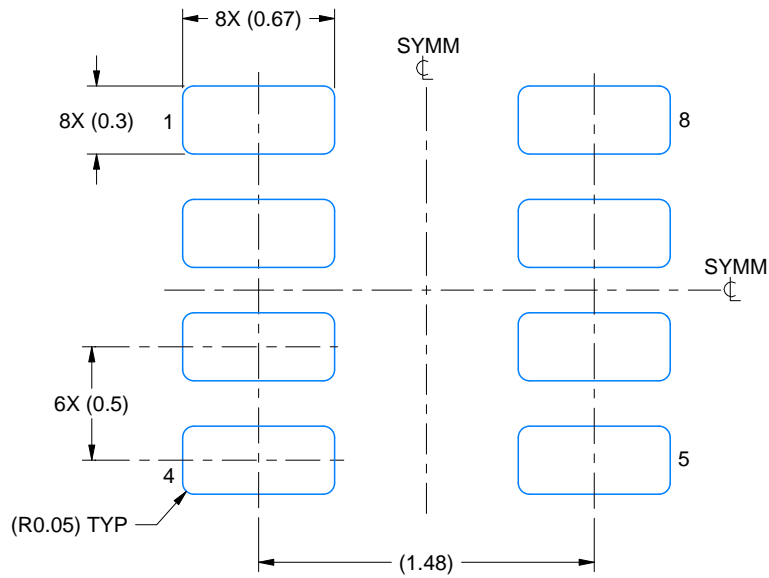

LAND PATTERN EXAMPLE
EXPOSED METAL SHOWN
SCALE:30X

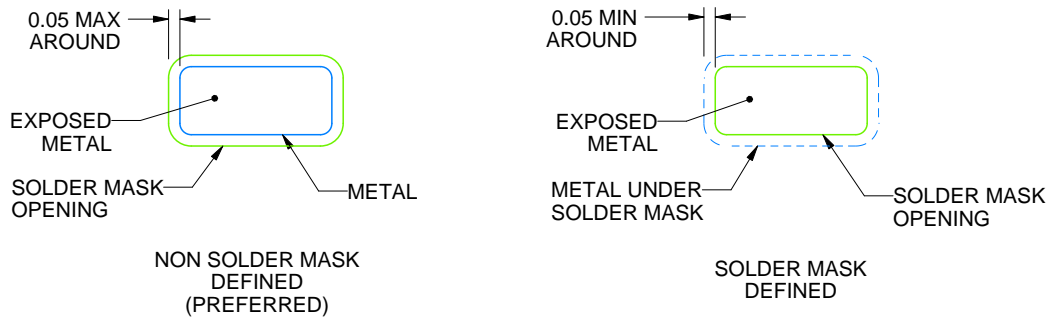

SOLDERMASK DETAILS

4224486/E 12/2021

NOTES: (continued)

5. Publication IPC-7351 may have alternate designs.
6. Solder mask tolerances between and around signal pads can vary based on board fabrication site.
7. Land pattern design aligns to IPC-610, Bottom Termination Component (BTC) solder joint inspection criteria.

EXAMPLE STENCIL DESIGN

DRL0008A

SOT-5X3 - 0.6 mm max height

PLASTIC SMALL OUTLINE

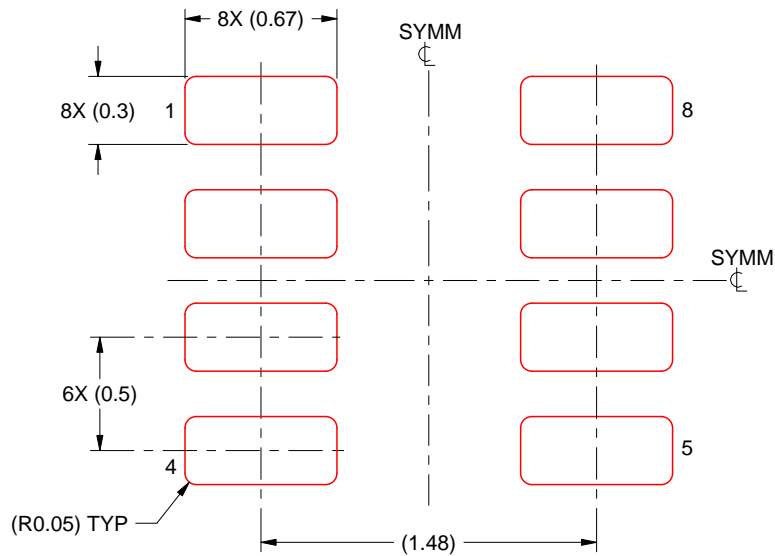

SOLDER PASTE EXAMPLE
BASED ON 0.1 mm THICK STENCIL
SCALE:30X

4224486/E 12/2021

NOTES: (continued)

8. Laser cutting apertures with trapezoidal walls and rounded corners may offer better paste release. IPC-7525 may have alternate design recommendations.
9. Board assembly site may have different recommendations for stencil design.

IMPORTANT NOTICE AND DISCLAIMER

TI PROVIDES TECHNICAL AND RELIABILITY DATA (INCLUDING DATA SHEETS), DESIGN RESOURCES (INCLUDING REFERENCE DESIGNS), APPLICATION OR OTHER DESIGN ADVICE, WEB TOOLS, SAFETY INFORMATION, AND OTHER RESOURCES "AS IS" AND WITH ALL FAULTS, AND DISCLAIMS ALL WARRANTIES, EXPRESS AND IMPLIED, INCLUDING WITHOUT LIMITATION ANY IMPLIED WARRANTIES OF MERCHANTABILITY, FITNESS FOR A PARTICULAR PURPOSE OR NON-INFRINGEMENT OF THIRD PARTY INTELLECTUAL PROPERTY RIGHTS.

These resources are intended for skilled developers designing with TI products. You are solely responsible for (1) selecting the appropriate TI products for your application, (2) designing, validating and testing your application, and (3) ensuring your application meets applicable standards, and any other safety, security, regulatory or other requirements.

These resources are subject to change without notice. TI grants you permission to use these resources only for development of an application that uses the TI products described in the resource. Other reproduction and display of these resources is prohibited. No license is granted to any other TI intellectual property right or to any third party intellectual property right. TI disclaims responsibility for, and you will fully indemnify TI and its representatives against, any claims, damages, costs, losses, and liabilities arising out of your use of these resources.

TI's products are provided subject to [TI's Terms of Sale](#) or other applicable terms available either on [ti.com](https://www.ti.com) or provided in conjunction with such TI products. TI's provision of these resources does not expand or otherwise alter TI's applicable warranties or warranty disclaimers for TI products.

TI objects to and rejects any additional or different terms you may have proposed.

Mailing Address: Texas Instruments, Post Office Box 655303, Dallas, Texas 75265
Copyright © 2023, Texas Instruments Incorporated