

Rockchip RV1106 Datasheet

Revision History

Date	Revision	Description
2022-04-27	1.1	Update MSL information and package thermal characteristics
2022-04-06	1.0	Initial released

Table of Content

Table of Content	2
Figure Index	3
Table Index.....	4
Warranty Disclaimer.....	5
Chapter 1 Introduction.....	6
1.1 Overview	6
1.2 Features	6
1.3 Block Diagram	14
Chapter 2 Package Information	15
2.1 Order Information	15
2.2 Top Marking	15
2.3 Package Dimension	15
2.4 Pin Number List	17
Chapter 3 Electrical Specification	19
3.1 Absolute Ratings	19
3.2 Recommended Operating Condition	19
3.3 DC Characteristics	20
3.4 Electrical Characteristics for General IO	20
3.5 Electrical Characteristics for PLL	21
3.6 Electrical Characteristics for USB2.0 Interface	21
3.7 Electrical Characteristics for MIPI CSI interface.....	22
3.8 Electrical Characteristics for Audio CODEC interface	22
3.9 Electrical Characteristics for SARADC	23
3.10 Electrical Characteristics for TSADC.....	23
Chapter 4 Thermal Management.....	24
4.1 Overview	24
4.2 Package Thermal Characteristics	24

Figure Index

Fig.1-1 Block Diagram14
Fig.2-1 Package definition15
Fig.2-2 Package Top View15
Fig.2-3 Package Bottom View16

Rockchip Confidential

Table Index

Table 2-1 Pin Number Order Information	17
Table 3-1 Absolute ratings.....	19
Table 3-2 Recommended operating condition	19
Table 3-3 DC Characteristics.....	20
Table 3-4 Electrical Characteristics for Digital General IO	20
Table 3-5 Electrical Characteristics for INT PLL	21
Table 3-6 Electrical Characteristics for FRAC PLL.....	21
Table 3-7 Electrical Characteristics for USB2.0 Interface	21
Table 3-8 HS Receiver AC specifications (for MIPI mode)	22
Table 3-9 LP Receiver AC specifications (for MIPI mode)	22
Table 3-10 HS Receiver AC specifications (for LVDS mode)	22
Table 3-11 Electrical Characteristics for Audio CODEC	22
Table 3-12 Electrical Characteristics for SARADC	23
Table 3-13 Electrical Characteristics for TSADC	23
Table 4-1 Thermal Resistance Characteristics.....	24

Warranty Disclaimer

Rockchip Electronics Co., Ltd makes no warranty, representation or guarantee (expressed, implied, statutory, or otherwise) by or with respect to anything in this document, and shall not be liable for any implied warranties of non-infringement, merchantability or fitness for a particular purpose or for any indirect, special or consequential damages.

Information furnished is believed to be accurate and reliable. However, Rockchip Electronics Co., Ltd assumes no responsibility for the consequences of use of such information or for any infringement of patents or other rights of third parties that may result from its use.

Rockchip Electronics Co., Ltd's products are not designed, intended, or authorized for using as components in systems intended for surgical implant into the body, or other applications intended to support or sustain life, or for any other application in which the failure of the Rockchip Electronics Co., Ltd's product could create a situation where personal injury or death may occur, should buyer purchase or use Rockchip Electronics Co., Ltd's products for any such unintended or unauthorized application, buyers shall indemnify and hold Rockchip Electronics Co., Ltd and its officers, employees, subsidiaries, affiliates, and distributors harmless against all claims, costs, damages, expenses, and reasonable attorney fees arising out of, either directly or indirectly, any claim of personal injury or death that may be associated with such unintended or unauthorized use, even if such claim alleges that Rockchip Electronics Co., Ltd was negligent regarding the design or manufacture of the part.

Copyright and Patent Right

Information in this document is provided solely to enable system and software implementers to use Rockchip Electronics Co., Ltd 's products. There are no expressed or implied copyright licenses granted hereunder to design or fabricate any integrated circuits or integrated circuits based on the information in this document.

Rockchip Electronics Co., Ltd does not convey any license under its patent rights nor the rights of others.

All copyright and patent rights referenced in this document belong to their respective owners and shall be subject to corresponding copyright and patent licensing requirements.

Trademarks

Rockchip and Rockchip™ logo and the name of Rockchip Electronics Co., Ltd's products are trademarks of Rockchip Electronics Co., Ltd. and are exclusively owned by Rockchip Electronics Co., Ltd. References to other companies and their products use trademarks owned by the respective companies and are for reference purpose only.

Confidentiality

The information contained herein (including any attachments) is confidential. The recipient hereby acknowledges the confidentiality of this document, and except for the specific purpose, this document shall not be disclosed to any third party.

Reverse engineering or disassembly is prohibited.

ROCKCHIP ELECTRONICS CO.,LTD. RESERVES THE RIGHT TO MAKE CHANGES IN ITS PRODUCTS OR PRODUCT SPECIFICATIONS WITH THE INTENT TO IMPROVE FUNCTION OR DESIGN AT ANY TIME AND WITHOUT NOTICE AND IS NOT REQUIRED TO UNDATE THIS DOCUMENTATION TO REFLECT SUCH CHANGES.

Copyright © 2022 Rockchip Electronics Co., Ltd.

All rights reserved. No part of this publication may be reproduced, stored in a retrieval system, or transmitted in any form or by any means, electric or mechanical, by photocopying, recording, or otherwise, without the prior written consent of Rockchip Electronics Co., Ltd.

Chapter 1 Introduction

1.1 Overview

RV1106 is a highly integrated vision processor SoC for IPC, especially for AI related application.

It is based on single-core ARM Cortex-A7 32-bit core which integrates NEON and FPU. There is a 32KB I-cache and 32KB D-cache and 128KB unified L2 cache.

The build-in NPU supports INT4/INT8/INT16 hybrid operation and computing power is up to 0.5TOPs. In addition, with its strong compatibility, network models based on a series of frameworks such as TensorFlow/MXNet/PyTorch/Caffe can be easily converted.

RV1106 introduces a new generation totally hardware-based maximum 5-Megapixel ISP (image signal processor). It implements a lot of algorithm accelerators, such as HDR, 3A, LSC, 3DNR, 2DNR, sharpening, dehaze, gamma correction and so on. Cooperating with two MIPI CSI (or LVDS) and one DVP (BT.601/BT.656/BT.1120) interface, users can build a system that receives video data from 3 camera sensors simultaneous.

The video encoder embedded in RV1106 supports H.265/H.264 encoding. It also supports multi-stream encoding. With the help of this feature, the video from camera can be encoded with higher resolution and stored in local memory and transferred another lower resolution video to cloud storage at the same time. To accelerate video processing, an intelligent video engine with 22 calculation units is also embedded.

RV1106 has a build-in 16-bit DRAM DDR3L capable of sustaining demanding memory bandwidths. It also integrated build-in RTC, POR, audio codec and MAC PHY.

1.2 Features

The features listed below which may or may not be present in actual product, may be subject to the third-party licensing requirements. Please contact Rockchip for actual product feature configurations and licensing requirements.

1.2.1 Application Processor

- Single core ARM Cortex-A7
- Full implementation of the ARM architecture v7-A instruction set, ARM Neon Advanced SIMD
- Separately Integrated Neon and FPU
- 32KB L1 I-Cache and 32KB L1 D-Cache
- Unified 128KB L2 Cache for Cortex-A7
- TrustZone technology support
- One isolated voltage domain to support DVFS

1.2.2 Memory Organization

- Internal on-chip memory
 - BootRom
 - ◆ Support system boot from the following device:
 - SPI interface
 - eMMC interface
 - SD/MMC interface
 - ◆ Support system code download by the following interface:
 - USB interface
 - UART interface
 - 256KB Share Memory
 - 8KB PMU SRAM
 - RV1106G2 SIP 1Gb DDR3L
- External off-chip memory
 - eMMC Interface
 - ◆ Fully compliant with JEDEC eMMC 4.51 specification
 - ◆ Support HS200, but not support CMD Queue

- ◆ Support three data bus width: 1bit, 4bits or 8bits
- SD/MMC Interface
 - ◆ Compatible with SD3.0, MMC ver4.51
 - ◆ Data bus width is 4bits
- Flexible Serial Flash Interface (FSPI)
 - ◆ Support transfer data from/to serial flash device
 - ◆ Support 1bit, 2bits or 4bits data bus width

1.2.3 System Component

- MCU
 - MCU in VD_CORE integrate 16KB Cache
 - Integrated Programmable Interrupt Controller, all IRQ lines connected to GIC for CPU also connect to MCU
 - Integrated Debug Controller with JTAG interface
- CRU (clock & reset unit)
 - Support total 4 PLLs to generate all clocks
 - One oscillator with 24MHz clock input
 - Support clock gating control for individual components
 - Support global soft-reset control for whole chip, also individual soft-reset for each component
- PMU (power management unit)
 - Multiple configurable work modes to save power by different frequency or automatic clock gating control or power domain on/off control
 - Lots of wakeup sources in different mode
 - Support 3 separate voltage domains, VDD_ARM, VDD_LOGIC, VDD_PMU.
- Timer
 - Support 2 secure timers with 64bits counter and interrupt-based operation
 - Support 6 non-secure timers with 64bits counter and interrupt-based operation
 - Support two operation modes: free-running and user-defined count for each timer
 - Support timer work state checkable
- PWM
 - Support 12 on-chip PWMs (PWM0~PWM11) with interrupt-based operation
 - Programmable pre-scaled operation to bus clock and then further scaled
 - Embedded 32-bit timer/counter facility
 - Support capture mode
 - Support continuous mode or one-shot mode
 - Provides reference mode and output various duty-cycle waveform
 - Optimized for IR application for PWM3, PWM7, PWM11
- Watchdog
 - 32-bit watchdog counter
 - Counter counts down from a preset value to 0 to indicate the occurrence of a timeout
 - WDT can perform two types of operations when timeout occurs:
 - ◆ Generate a system reset
 - ◆ First generate an interrupt and if this is not cleared by the service routine by the time a second timeout occurs then generate a system reset
 - One Watchdog for non-secure application
 - One Watchdog for secure application
- Interrupt Controller
 - Support 121 SPI interrupt sources input from different components inside RV1106
 - Support 16 software-triggered interrupts
 - Input interrupt level is fixed, high-level sensitive or rising edge sensitive

- Support different interrupt priority for each interrupt source, and they are always software-programmable
- DMAC
 - Micro-code programming-based DMA
 - Linked list DMA function is supported to complete scatter-gather transfer
 - Support data transfer types including memory-to-memory, memory-to-peripherals, peripherals-to-memory
 - Totally three embedded DMA controllers for peripheral system
 - Each DMAC features:
 - ◆ Support 8 channels
 - ◆ 32 hardware requests from peripherals
 - ◆ 2 interrupt output
 - ◆ Support TrustZone technology and programmable secure state for each DMA channel
- Secure System
 - Embedded one cipher engines
 - ◆ Support Link List Item (LLI) DMA transfer
 - ◆ Support SHA-1, SHA-256/224, MD5 with hardware padding
 - ◆ Support HMAC of SHA-1, SHA-256, MD5 with hardware padding
 - ◆ Support AES-128, AES-192, AES-256 encrypt and decrypt cipher
 - ◆ Support DES and TDES cipher
 - ◆ Support AES ECB/CBC/OFB/CFB/CTR/CTS/XTS/GCM/CBC-MAC/CMAC mode
 - ◆ Support DES/TDES ECB/CBC/OFB/CFB mode
 - ◆ Support up to 4096 bits PKA mathematical operations for RSA/ECC/SM2
 - Support generating random numbers, one secure only engine, another one security configurable
 - Support secure OTP
 - Support secure debug
 - Support secure OS
 - Except CPU, the other masters in the SoC can also support security and non-security mode by software-programmable
 - Some slave components in SoC can only be addressed by security master and the other slave components can be addressed by security master or non-security master by software-programmable
 - System SRAM (share memory), part of space is addressed only in security mode
 - External DDR space can be divided into 16 parts, each part can be software-programmable to be enabled by each master
- Mailbox
 - One Mailbox in SoC to service CPU and MCU communication
 - Support four mailbox elements, each element includes one data word, one command word register and one flag bit that can represent one interrupt
 - Provide 32 lock registers for software to use to indicate whether mailbox is occupied
- Decompression
 - Support for decompressing GZIP files
 - Support for decompressing data in DEFLATE format
 - Support for decompressing data in ZLIB format
 - Support the limit size function of the decompressed data to prevent the memory from being maliciously destroyed during the decompression process
- Real Time Clock (RTC)
 - Provides year, month, day, weekday, hours, minutes, and seconds based on a 32.768 kHz crystal oscillator
 - Support compensation for the second and hour count

- BCD representation of time, calendar and alarm
- 12- or 24-hour clock with AM and PM in 12-hour mode
- Interrupts are separately software maskable
 - ◆ Alarm interrupt
 - ◆ Periodic interrupt
 - ◆ Chip power off interrupt
 - ◆ Battery power atypical interrupt

1.2.4 Video CODEC

- Video Encoder
 - H.265/HEVC Main Profile, level 5.0
 - H.264/AVC High Profile, level 5.0
 - Support multi-channel encoding with performance up to 5-megapixel@30fps
 - JPEG baseline, up to 4-megapixel @60fps in standalone mode, resolution up to 8192 x 8192
 - Bitrate up to 60Mbps
 - Six bit rate control modes (CBR, VBR, FIXQP, AVBR, QPMAP, and CVBR)
 - Support YUV420 and YUV400 format input
 - Intelligent encoding mode
 - 8-area OSD
 - YUV/RGB video source with crop, rotation and mirror
 - Ultra-low delay encoding

1.2.5 Neural Process Unit

- Neural network acceleration engine with processing performance up to 0.5 TOPS
- Support integer 4, integer 8 and integer 16 operation
- Support creating simple custom operators
- Support deep learning frameworks: TensorFlow, Caffe, Tflite, Pytorch, Onnx NN, etc.

1.2.6 Rockchip Intelligent Video Engine (RKIVE)

- GMM
 - Support 1 to 5 gaussian model
- BGM (base on codebook)
 - Support 3 codebook model
- Canny
 - Staging buffer stride require 64 pixel align
 - Support 3X3 and 5x5 template coefficient
- CCL
 - Support max to 254 connected regions
 - Support 4-connected and 8-connected region
- Stcorner
 - Support max to 500 corner sort output
- LK
 - Support max to 500 corner input
 - Support 1~4 optical flow layers
- Integral
 - Require all the buffer base is 16bytes align
- LBP
 - Support simple and absolute value comparison mode
- Filter
 - Support 3X3 and 5x5 mode
- Sobel
 - Support 3X3 and 5x5 mode
- Morph
 - Support eroding and dilating mode
- Denoise Filter
 - Support minimum/median/maximum 3 types filter
- DMA

- Support direct copy mode
- Support interval copy mode
- CSC
 - Support rgb2yuv, yuv2rgb, rgb2hsv, yuv2hsv
 - Support 601 and 709 format, full and limit range
- Hist/eqhist
 - Support hist only, eqhist only, hist + eqhist 3 types mode
- Logic OP
 - Support logic and, logic or, logic xor, add, sub, absolute difference
- Mag and Ang
 - Calculation of the image gradient magnitude and direction
- Morph
 - Support eroding and dilating mode
- NCC
 - Calculation of the image normalized cross-correlation
- Cast
 - Data linear transformation
- Sad
 - Support sad size is 4x4, 8x8 and 16x16
- Threshold
 - Convert grayscale into a binary image
- Map
 - Support 8bit to 8bit and 8bit to 16bit map operation

1.2.7 Graphics Engine

- 2D Graphics Engine
 - Input data:
 - ◆ ARGB/RGB888/RGB565/RGB4444/RGB5551
 - ◆ YUV420/YUV422/YVYU422/YVYU420/YUV422SP10bit/YUV420SP10bit
 - Output data:
 - ◆ ARGB/RGB888/RGB565/RGB4444/RGB5551
 - ◆ YUV420/YUV422/YUV400/Y4/YVYU422/YVYU420
 - Pixel Format conversion, BT.601/BT.709
 - Dither operation
 - Max resolution: 8192x8192 source, 4096x4096 destination
 - Scaling
 - ◆ Down-scaling: Average filter
 - ◆ Up-scaling: Bi-cubic filter(source>2048 would use Bi-linear)
 - ◆ Arbitrary non-integer scaling ratio, from 1/16 to 16
 - Rotation
 - ◆ 0, 90, 180, 270-degree rotation
 - ◆ x-mirror, y-mirror
 - ◆ Mirroring and rotation co-operation
 - BitBLT
 - ◆ Block transfer
 - ◆ Color palette/Color fill, support with alpha
 - ◆ Transparency mode (color keying/stencil test, specified value/value range)
 - ◆ Two source BitBLT
 - ◆ A+B=B only BitBLT, A support rotate & scale when B fixed
 - ◆ A+B=C second source (B) has same attribute with (C) plus rotation function
 - Alpha Blending
 - ◆ Comprehensive per-pixel alpha(color/alpha channel separately)
 - ◆ Fading
 - ◆ Support SRC1(R2Y)+SRC0(YUV) -> DST(YUV)
 - ◆ Support DST Full CSC convert for YUV2YUV
 - OSD Automatic Inversion
 - ◆ Supports OSD sources in ARGB8888/ARGB1555/ARGB444/ARGB2BPP format
 - ◆ Support SRC0 and OSD overlay

- Support square mosaic patterns to cover rectangular mosaic areas

1.2.8 Video Input Interface

- MIPI Interface
 - Two MIPI CSI DPHY
 - ◆ Each MIPI DPHY V1.2, 2lanes, 1.5Gbps per lane
 - ◆ Support to combine 2 DPHY together to one 4lanes
- DVP interface
 - One 8/10/12/16-bit standard DVP interface, up to 100MHz input data
 - Support BT.601/BT.656 and BT.1120 VI interface
 - Support the polarity of pixel_clk, hsync, vsync configurable

1.2.9 Image Signal Processor

- Video Capture (VICAP)
 - Support BT601 YCbCr 422 8bit input, RAW 8/10/12bit input
 - Support BT656 YCbCr 422 8bit progressive/interlace input
 - Support BT1120 YCbCr 422 16bit progressive/interlace input, single/dual-edge sampling
 - Support YUYV sequence configurable
 - Support the polarity of hsync and vsync configurable
 - Support receiving two interfaces of MIPI CSI /LVDS, up to four IDs for each interface
 - Support five CSI data formats: RAW8/10/12/14, YUV422
 - Support three modes of MIPI CSI HDR: virtual channel mode, identification code mode, line counter mode
 - Support four LVDS data formats: RAW8/10/12, YUV422
 - Support reducing frame rate
 - Support window cropping
 - Support RAW data through to ISP
 - Support 8/16/32 times down-sampling for RAW data
 - Support virtual stride when write to DDR
 - Support NV16/NV12/YUV400/YUYV output format for YUV data
 - Support compact/non-compact output format for RAW data
- Maximum input: 3072x1728 (5M) @30fps
- Minimum input: 256x256
- 3A: Include Auto Enhance (AE)/Histogram, Auto Focus (AF), and Auto White Balance (AWB) statistics output
- EXPANDER: Sensor expander
- BLC: Black Level Correction
- DPCC: Static/Dynamic Defect Pixel Cluster Correction
- PDAF: Phase Detection Auto Focus
- LSC: Lens Shading Correction
- Bayer-2DNR: Spatial Bayer-raw Noise Reduction
- Bayer-3DNR: Temporal Bayer-raw Noise Reduction
- CAC: Chromatic Aberration Correction
- HDR-MGE: 2-Frame Merge into High-Dynamic Range
- HDR-DRC: HDR Dynamic Range Compression, Tone mapping
- GIC: Green Imbalance Correction
- DeBayer: Advanced Adaptive Demosaic
- CCM/CSM: Color Correction Matrix, RGB2YUV, etc.
- Gamma: Gamma out correction
- Dehaze/Enhance: Automatic Dehaze and effect enhancement
- 3DLUT: 3D-LUT Color Palette for Customer
- LDCH: Lens Distortion Correction only in the Horizontal direction
- YUV-2DNR: Spatial YUV Noise Reduction
- Sharp: Image sharpening and boundary filtering
- CMSK: Privacy cover and mask
- Gain: Image local gain

- Multi-sensor reuse ISP, 4 sensors for maximum
- Bus interface: 32bit AHB configuration, 128bit AXI R/W
- Low power, auto-gating for each block
- MI R/W burst group to improve memory utilization
- MI 3+2 path output, MP stepless scaling, SP/BP scaling under 1080p, MPDS/SPDS fixed 1/16 downscaling

1.2.10 Display interface

- Parallel RGB LCD Interface: 18-bit (RGB666), 16-bit (RGB565)
- Serial RGB LCD Interface
- MCU LCD Interface
- Max output resolution: 1280x720 for RGB/BT656/BT1120

1.2.11 Video Output Processor

- Display process
 - Background layer
 - ◆ programmable 18-bit color
 - Win1 layer
 - ◆ RGB888, ARGB888, RGB565
 - ◆ Support virtual display
 - ◆ 256 level alpha blending (pre-multiplied alpha support)
 - ◆ Transparency color key
 - ◆ RGB2YCbCr (BT601/BT709)
- Others
 - Support RGB or YUV domain overlay
 - BCSH (Brightness, Contrast, Saturation, Hue adjustment)
 - BCSH: YCbCr2RGB (rec601-mpeg/ rec601-jpeg/rec709)
 - BCSH: RGB2YCbCr (BT601/BT709)
 - Support dither down allegro RGB888to666 RGB888to565 & dither down frc (configurable) RGB888to666
 - Blank and black display
 - Standby mode
 - Support all layers reg_done separately

1.2.12 Audio Interface

- I2S0 with 8 channels
 - Up to 8 channels TX and 8 channels RX path
 - Audio resolution from 16bits to 32bits
 - Sample rate up to 192KHz
 - Provides master and slave work mode, software configurable
 - Support 3 I2S formats (normal, left-justified, right-justified)
 - Support 4 PCM formats (early, late1, late2, late3)
- Audio Codec
 - Support two 24-bits ADC channels with 90dB SNR for stereo recording from microphone
 - Support one 24-bits DAC channels with 90dB SNR for stereo playback
 - Support differential and single-ended microphone or line input
 - Sampling rate of 8KHz/12KHz/16KHz/24KHz/32KHz/44.1kHz/48KHz/96KHz

1.2.13 Connectivity

- SDIO interface
 - Compatible with SDIO3.0 protocol
 - 4-bit data bus widths
- MAC 10/100M Ethernet controller and embedded PHY
 - Support one Ethernet controllers
 - Support 10/100-Mbps data transfer rates with the RMI interfaces

- Support both full-duplex and half-duplex operation
- USB 2.0
 - Compatible with USB 2.0 specification
 - Support one USB 2.0 Host/Device
 - Supports high-speed(480Mbps), full-speed(12Mbps) and low-speed(1.5Mbps) mode
 - Support Enhanced Host Controller Interface Specification (EHCI), Revision 1.0
 - Support Open Host Controller Interface Specification (OHCI), Revision 1.0a
- SPI interface
 - Support 2 SPI Controllers (SPI0-SPI1)
 - Support two chip-select output
 - Support serial-master and serial-slave mode, software-configurable
- I2C Master controller
 - Support 5 I2C Master(I2C0-I2C4)
 - Support 7bits and 10bits address mode
 - Software programmable clock frequency
 - Data on the I2C-bus can be transferred at rates of up to 100k bits/s in the Standard-mode, up to 400k bits/s in the Fast-mode
- UART interface
 - Support 6 UART interfaces (UART0-UART5)
 - Embedded two 64-byte FIFO for TX and RX operation respectively
 - Support 5bit, 6bit, 7bit, 8bit serial data transmit or receive
 - Standard asynchronous communication bits such as start, stop and parity
 - Support different input clock for UART operation to get up to 4Mbps baud rate
 - Support auto flow control mode for all UART

1.2.14 Others

- Multiple groups of GPIO
 - All of GPIOs can be used to generate interrupt
 - Support level trigger and edge trigger interrupt
 - Support configurable polarity of level trigger interrupt
 - Support configurable rising edge, falling edge and both edge trigger interrupt
 - Support configurable pull direction (a weak pull-up and a weak pull-down)
 - Support configurable drive strength
- Temperature Sensor (TS-ADC)
 - Support User-Defined Mode and Automatic Mode
 - In User-Defined Mode, start_of_conversion can be controlled completely by software, and also can be generated by hardware.
 - In Automatic Mode, the temperature of alarm (high/low temperature) interrupt can be configurable
 - In Automatic Mode, the temperature of system reset can be configurable
 - -40~125°C temperature range and 1°C temperature resolution
- Successive approximation ADC (SARADC)
 - 10-bit resolution
 - Up to 1MS/s sampling rate
 - 2 single-ended input channels
- OTP
 - Support 8K bits Size, 7K bits for secure application
 - Support Program/Read/Idle mode
- Package Type
 - RoHS QFN128 (body: 12.3mm x 12.3mm pitch 0.35mm)

1.3 Block Diagram

The following diagram shows the basic block diagram.

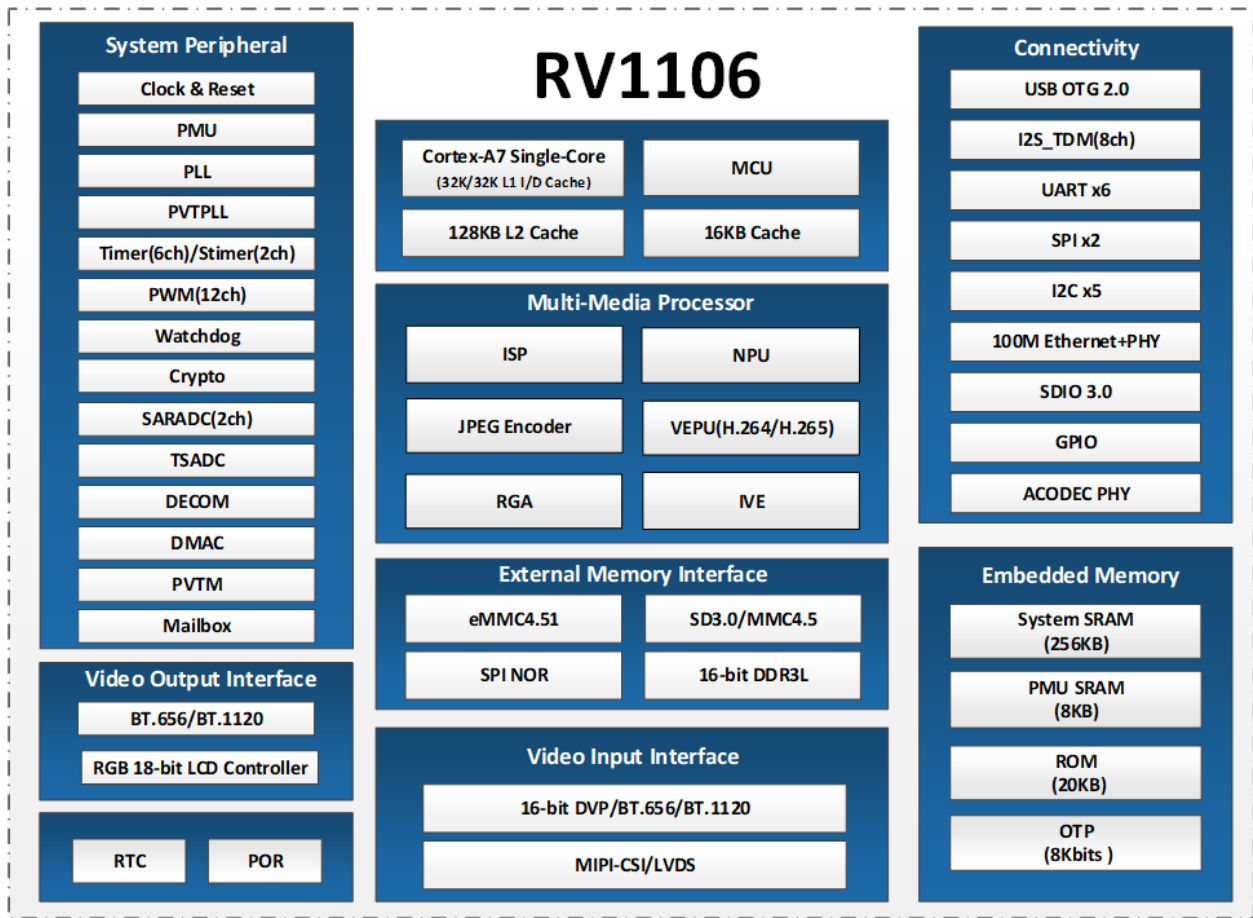

Fig.1-1 Block Diagram

Chapter 2 Package Information

2.1 Order Information

Orderable Device	RoHS status	Package	Package Q'ty	Device Feature
RV1106G2	RoHS	QFN128	1520 pcs by tray	Cortex A7 + MCU + 1Gb DDR3L

2.2 Top Marking

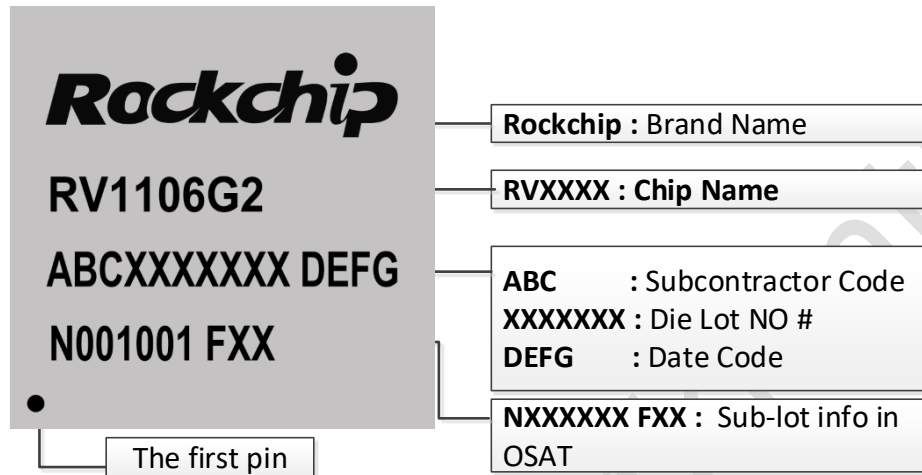

Fig.2-1 Package definition

2.3 Package Dimension

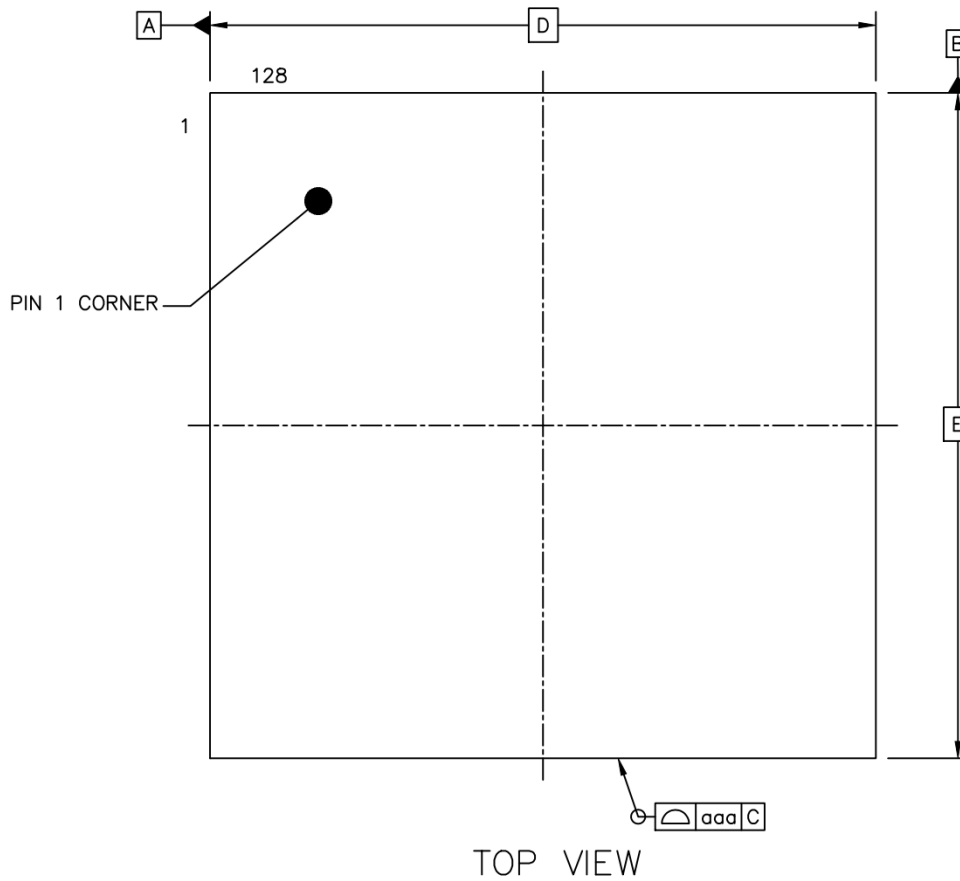

Fig.2-2 Package Top View

		SYMBOL	MIN	NOM	MAX
TOTAL THICKNESS		A	0.8	0.85	0.9
STAND OFF		A1	0	0.02	0.05
MOLD THICKNESS		A2	---	0.7	---
L/F THICKNESS		A3	0.152 REF		
LEAD WIDTH		b	0.08	0.13	0.18
BODY SIZE	X	D	12.3 BSC		
	Y	E	12.3 BSC		
LEAD PITCH		e	0.35 BSC		
EP SIZE	X	D2	6.9	7	7.1
	Y	E2	6.9	7	7.1
LEAD LENGTH		L	0.3	0.4	0.5
LEAD TIP TO EXPOSED PAD EDGE		K	2.25 REF		
PACKAGE EDGE TOLERANCE		aaa	0.1		
MOLD FLATNESS		ccc	0.1		
COPLANARITY		eee	0.08		
LEAD OFFSET		bbb	0.07		
EXPOSED PAD OFFSET		fff	0.1		

Fig.2-5 Package Dimension

2.4 MSL Information

Moisture sensitivity Level : MSL3

2.5 Pin Number List

Table 2-1 Pin Number Order Information

Pin Name	Pin	Pin Name	Pin
MIPI_AVDD1V8/GPIO7_VCC1V8	1	I2C1_SDA_M0/UART1_CTS_M0/PWM6_M0/GPIO0_A6_d	65
VI_CIF_CLK0_M0/MIPI_CLK0_OUT/GPIO3_C4_d	2	nPOR	66
VI_CIF_VSYNC_M0/GPIO3_C5_d	3	PMU_DVDD0V9	67
VI_CIF_D10/PWM7_IR_M2/MIPI_CLK1_OUT/GPIO3_C6_d	4	OSC_XIN	68
VI_CIF_D11/UART5_TX_M2/I2C4_SCL_M2/GPIO3_C7_d	5	OSC_XOUT	69
VI_CIF_D13/UART5_RTS_M2/I2C3_SCL_M2/GPIO3_D1_d	6	OSC_AVDD1V8/PLL_AVDD1V8	70
VI_CIF_D12/UART5_RX_M2/I2C4_SDA_M2/GPIO3_D0_d	7	OSC_PLL_DVDD	71
VI_CIF_D14/UART5_CTS_M2/I2C3_SDA_M2/GPIO3_D2_d	8	UART3_TX_M0/I2C2_SCL_M0/PWM7_IR_M0/GPIO1_A0_d	72
VI_CIF_D15/PWM1_M2/GPIO3_D3_d	9	UART3_RX_M0/I2C2_SDA_M0/PWM4_M0/GPIO1_A1_d	73
DVDD_1	10	PWM0_M0/CPU_AVS/VI_CIF_D0_M1/GPIO1_A2_d	74
SDMMC0_DET/GPIO3_A1_u	11	UART1_TX_M0/I2C0_SCL_M0/GPIO1_A3_d	75
SDMMC0_D1/UART2_TX_M0/PWM9_M0/GPIO3_A2_u	12	UART1_RX_M0/I2C0_SDA_M0/GPIO1_A4_d	76
GPIO4_VCC	13	UART4_RX_M0/PWM3_IR_M1/GPIO1_B0_d	77
SDMMC0_D0/UART2_RX_M0/PWM8_M0/GPIO3_A3_u	14	UART4_TX_M0/PWM7_IR_M1/SPI1_CS1_M0/VI_CIF_D1_M1/GPIO1_B1_d	78
SDMMC0_CLK/UART5_RTS_M0/I2C0_SCL_M2/JTAG_LPMCU_TCK_M1/PWM10_M0/GPIO3_A4_d	15	JTAG_CPU_TCK_M1/UART2_TX_M1/JTAG_HPMCU_TCK_M0/JTAG_LPMCU_TCK_M0/GPIO1_B2_d	79
SDMMC0_CMD/UART5_CTS_M0/I2C0_SDA_M2/JTAG_LPMCU_TMS_M1/PWM11_IR_M0/GPIO3_A5_u	16	JTAG_CPU_TMS_M1/UART2_RX_M1/JTAG_HPMCU_TMS_M0/JTAG_LPMCU_TMS_M0/GPIO1_B3_u	80
SDMMC0_D3/UART5_TX_M0/JTAG_CPU_TMS_M0/JTAG_HPMCU_TMS_M1/GPIO3_A6_u	17	GPIO1_VCC3V3	81
SDMMC0_D2/UART5_RX_M0/JTAG_CPU_TCK_M0/JTAG_HPMCU_TCK_M1/GPIO3_A7_u	18	DVDD_5	82
RTC_AVDD3V3	19	VO_LCDC_D1/VI_CIF_D8_M1/PWM10_M1/UART4_RTS_M1/GPIO1_C6_d	83
RTC_XOUT	20	VO_LCDC_D0/VI_CIF_D9_M1/PWM11_IR_M1/UART4_CTS_M1/GPIO1_C7_d	84
RTC_XIN	21	VO_LCDC_CLK/VI_CIF_CLK0_M1/I2C3_SCL_M1/UART5_TX_M1/PWM11_IR_M2/AUD_DSM_N/GPIO1_D3_d	85
SARADC_IN1/PWM1_M1/GPI4_C1_z	22	VO_LCDC_VSYNC/VI_CIF_VSYNC_M1/I2C3_SDA_M1/UART5_RX_M1/SPI0_CS1_M0/PWM0_M1/AUD_DSM_P/GPIO1_D2_d	86
SARADC_IN0/GPI4_C0_z	23	VO_LCDC_HSYNC/VI_CIF_HREF_M1/PWM10_M2/UART5_CTS_M1/UART3_RX_M1/GPIO1_D1_d	87
SARADC_USB_AVDD1V8	24	GPIO6_VCC	88
USB_VBUSDET	25	VO_LCDC_DEN/VI_CIF_CLK1_M1/PWM3_IR_M2/UART5_RTS_M1/UART3_TX_M1/GPIO1_D0_d	89
USB_DM	26	VO_LCDC_D2/VI_CIF_D7_M1/PWM9_M1/UART4_TX_M1/SDMMC1_D2_M1/GPIO1_C5_d	90

Pin Name	Pin	Pin Name	Pin
USB_DP	27	VO_LCDC_D3/VI_CIF_D6_M1/PWM8_M1/UART4_RX_M1/SDMMC1_D3_M1/GPIO1_C4_d	91
USB_AVDD3V3	28	VO_LCDC_D4/VI_CIF_D5_M1/PWM6_M2/I2C4_SDA_M1/SDMMC1_CMD_M1/SPI0_MISO_M0/GPIO1_C3_d	92
CODEC_LINEOUT	29	VO_LCDC_D5/VI_CIF_D4_M1/PWM5_M2/I2C4_SCL_M1/SDMMC1_CLK_M1/SPI0_MOSI_M0/GPIO1_C2_d	93
CODEC_VCM	30	VO_LCDC_D6/VI_CIF_D3_M1/PWM4_M2/SPI0_CLK_M0/SDMMC1_D0_M1/GPIO1_C1_d	94
CODEC_AVDD1V8	31	VO_LCDC_D7/VI_CIF_D2_M1/PWM2_M2/SPI0_CS0_M0/SDMMC1_D1_M1/GPIO1_C0_d	95
CODEC_MICBIAS	32	OTP_AVDD1V8/ETH_AVDD1V8/TSADC_AVDD1V8	96
CODEC_MIC0N	33	ETH_PHY_RXN	97
CODEC_MIC0P	34	ETH_PHY_RXP	98
CODEC_MIC1N	35	ETH_PHY_TXN	99
CODEC_MIC1P	36	ETH_PHY_TXP	100
CODEC_AVSS	37	ETH_AVDD3V3	101
EMMC_D5/SPI1_CLK_M0/UART1_RX_M2/I2C2_SCL_M1/GPIO4_A7_u	38	ETH_EXTR	102
EMMC_D3/FSPI_D3/GPIO4_A6_u	39	DVDD_6	103
EMMC_D4/SPI1_CS0_M0/UART1_TX_M2/I2C2_SDA_M1/GPIO4_A5_u	40	UART0_TX_M1/I2C1_SDA_M1/VO_LCDC_D17/PWM6_M1/GPIO2_B1_d	104
EMMC_D0/FSPI_D0/GPIO4_A4_u	41	UART0_TX_M1/I2C1_SDA_M1/VO_LCDC_D17/PWM6_M1/GPIO2_B1_d	105
EMMC_D1/FSPI_D1/GPIO4_A3_u	42	UART0_CTS_M1/I2S0_SDO1_SDI3/VO_LCDC_D15/PWM4_M1/I2C3_SDA_M0/PRELIGHT_TRIG_OUT/GPIO2_A7_d	106
GPIO3_VCC	43	UART0_RTS_M1/I2S0_SDO2_SDI2/VO_LCDC_D14/PWM2_M1/I2C3_SCL_M0/FLASH_TRIG_OUT/GPIO2_A6_d	107
EMMC_D2/FSPI_D2/GPIO4_A2_u	44	GPIO5_VCC	108
EMMC_D6/SPI1_MOSI_M0/UART0_TX_M2/I2C0_SCL_M1/GPIO4_A1_u	45	SDMMC1_D1_M0/I2S0_SCLK/VO_LCDC_D8/UART1_CTS_M1/I2C4_SDA_M0/GPIO2_A0_d	109
EMMC_D7/SPI1_MISO_M0/UART0_RX_M2/I2C0_SDA_M1/GPIO4_A0_u	46	SDMMC1_D1_M0/I2S0_SCLK/VO_LCDC_D8/UART1_CTS_M1/I2C4_SDA_M0/GPIO2_A0_d	110
EMMC_CMD/FSPI_CS0/GPIO4_B0_u	47	SDMMC1_CLK_M0/I2S0_MCLK/VO_LCDC_D10/GPIO2_A2_d	111
EMMC_CLK/FSPI_CLK/GPIO4_B1_d	48	SDMMC1_CMD_M0/I2S0_SDO3_SDI1/VO_LCDC_D11/GPIO2_A3_d	112
DDR_VDDQ_1	49	SDMMC1_D3_M0/I2S0_SDO0/VO_LCDC_D12/UART1_TX_M1/GPIO2_A4_d	113
DDR_VDDQ_2	50	SDMMC1_D2_M0/I2S0_SDI0/VO_LCDC_D13/UART1_RX_M1/GPIO2_A5_d	114
DVDD_2	51	CPU_DVDD	115
DRAM_ZQ	52	DVDD_7	116
DDR_PLL_AVDD1V8	53	VI_CIF_D0_M0/MIPI_CSI_RX_D3N/LVDS_RX_D3N/GPIO3_B0_d	117
DVDD_3	54	VI_CIF_D1_M0/MIPI_CSI_RX_D3P/LVDS_RX_D3P/GPIO3_B1_d	118
DVDD_4	55	VI_CIF_D2_M0/MIPI_CSI_RX_CK1N/LVDS_RX_CK1N/GPIO3_B2_d	119
DDR_VDDQ_3	56	VI_CIF_D3_M0/MIPI_CSI_RX_CK1P/LVDS_RX_CK1P/GPIO3_B3_d	120
TVSS	57	VI_CIF_D4_M0/MIPI_CSI_RX_D2N/LVDS_RX_D2N/GPIO3_B4_d	121
UART0_RX_M0/CLK_32K/CLK_REFOUT/RTC_CLKO/GPIO0_A0_z	58	VI_CIF_D5_M0/MIPI_CSI_RX_D2P/LVDS_RX_D2P/GPIO3_B5_d	122
UART0_TX_M0/PWM2_M0/GPIO0_A1_d	59	VI_CIF_D6_M0/MIPI_CSI_RX_D1N/LVDS_RX_D1N/GPIO3_B6_d	123
PWM3_IR_M0/GPIO0_A2_d	60	VI_CIF_D7_M0/MIPI_CSI_RX_D1P/LVDS_RX_D1P/GPIO3_B7_d	124
PMU_VCC3V3	61	VI_CIF_D8_M0/MIPI_CSI_RX_CK0N/LVDS_RX_CK0N/GPIO3_C0_d	125
PMIC_PWR_CTRL_M1/GPIO0_A3_u	62	VI_CIF_D9_M0/MIPI_CSI_RX_CK0P/LVDS_RX_CK0P/GPIO3_C1_d	126
PMIC_PWR_CTRL_M0/PWM1_M0/GPIO0_A4_d	63	VI_CIF_CLKI_M0/MIPI_CSI_RX_D0N/LVDS_RX_D0N/GPIO3_C2_d	127
I2C1_SCL_M0/UART1_RTS_M0/PWM5_M0/GPIO0_A5_d	64	VI_CIF_HREF_M0/MIPI_CSI_RX_D0P/LVDS_RX_D0P/GPIO3_C3_d	128
		VSS	E-PAD

Chapter 3 Electrical Specification

3.1 Absolute Ratings

The below table provides the absolute ratings.

Absolute maximum or minimum ratings specify the values beyond which the device may be damaged permanently. Long-term exposure to absolute maximum ratings conditions may affect device reliability.

Table 3-1 Absolute ratings

Parameters	Related Power Group	Min	Max	Unit
Supply voltage for CPU	CPU_DVDD	0	TBD	V
Supply voltage for LOGIC	DVDD _i (i=1~7)	0	0.99	V
Supply voltage for PMU	PMU_DVDD0V9	0	0.99	V
Supply voltage for RTC	RTC_AVDD3V3	0	3.6	V
0.9V supply voltage	DVDD _i (i=1~7) PMU_DVDD0V9 OSC_PLL_DVDD	0	0.99	V
1.8V/3.3V supply voltage	GPIO _i _VCC(i=3~6, 1.8V/3.3V mode)	0	3.63	V
1.8V supply voltage	OSC_AVDD1V8/PLL_AVDD1V8 MIPI_AVDD1V8/GPIO7_VCC1V8 SARADC_USB_AVDD1V8 DDR_PLL_AVDD1V8 OTP_AVDD1V8/ETH_AVDD1V8/TSADC_AVDD1V8 CODEC_AVDD1V8	0	1.98	V
3.3V supply voltage	GPIO1_VCC3V3 PMU_VCC3V3 RTC_AVDD3V3 USB_AVDD3V3 ETH_AVDD3V3	0	3.63	V
Supply voltage for DDR IO	VDDIO_DDR _j (j=1~3)	0	TBD	V
Storage Temperature	Tstg	NA	NA	°C
Max Conjunction Temperature	Tj	NA	NA	°C

3.2 Recommended Operating Condition

Following table describes the recommended operating condition.

Table 3-2 Recommended operating condition

Parameters	Symbol	Min	Typ	Max	Unit
Voltage for CPU	CPU_DVDD	TBD	0.90	TBD	V
Voltage for LOGIC	DVDD _j (j=1~7)	0.81	0.90	TBD	V
Voltage for PMU	PMU_DVDD0V9	0.81	0.90	TBD	V
Voltage for RTC	RTC_AVDD3V3	1.6	3.3	3.6	V
Voltage for PLL Analog (1.8V)	OSC_AVDD1V8/PLL_AVDD1V8	1.62	1.8	TBD	V
Voltage for GPIO (1.8V/3.3V)	GPIO _i _VCC(i=3~6)	1.62 3.0	1.8 3.3	1.98 3.465	V
Voltage for GPIO (1.8V only)	MIPI_AVDD1V8/GPIO7_VCC1V8	1.62	1.8	1.98	V
Voltage for GPIO (3.3V only)	GPIO1_VCC3V3 PMU_VCC3V3	3.0	3.3	3.465	V
Voltage for USB/SARADC Analog (1.8V)	SARADC_USB_AVDD1V8	1.62	1.8	1.98	V
Voltage for USB Analog (3.3V)	USB_AVDD3V3	3.0	3.3	3.6	V
Voltage for OTP/MAC Analog (1.8V)	OTP_AVDD1V8/ETH_AVDD1V8/TSADC_AVDD1V8	1.62	1.8	1.98	V
Voltage for MAC Analog (3.3V)	ETH_AVDD3V3	2.97	3.3	3.63	V
Voltage for CODEC Analog	CODEC_AVDD1V8	1.62	1.8	1.98	V
Voltage for MIPI Analog	MIPI_AVDD1V8/GPIO7_VCC1V8	1.62	1.8	1.98	V
Voltage for DDR PHY PLL	DDR_PLL_AVDD1V8	TBD	1.8	TBD	V
Ambient Operating Temperature	T _A	0	NA	80	°C

3.3 DC Characteristics

Table 3-3 DC Characteristics

Parameters		Symbol	Min	Typ	Max	Unit
Digital GPIO @3.3V	Input Low Voltage	Vil	-0.3	NA	0.8	V
	Input High Voltage	Vih	2.0	NA	VDDO+0.3	V
	Output Low Voltage	Vol	-0.3	NA	0.4	V
	Output High Voltage	Voh	2.4	NA	VDDO+0.3	V
	Pullup Resistor	Rpu	16	25	43	Kohm
	Pulldown Resistor	Rpd	16	25	43	Kohm
Digital GPIO @1.8V	Input Low Voltage	Vil	-0.3	NA	0.35*VDDO	V
	Input High Voltage	Vih	0.65*VDDO	NA	VDDO+0.3	V
	Output Low Voltage	Vol	-0.3	NA	0.4	V
	Output High Voltage	Voh	1.4	NA	VDDO+0.3	V
	Pullup Resistor	Rpu	16	25	43	Kohm
	Pulldown Resistor	Rpd	16	25	43	Kohm

Parameters		Symbol	Min	Typ	Max	Unit
MIPI_LVDS Combo IO@LVDS HS receiver mode	Common-mod voltage HS receive mode	VCMRX(DC)	0.8	NA	1.32	V
	Differential input high threshold	VIDTH	NA	NA	70	mV
	Differential input low threshold	VIDTL	-70	NA	NA	mV
	Single-ended input high voltage	VIHHS	NA	NA	1.5	V
	Single-ended input low voltage	VILHS	-40	NA	NA	mV
	Differential input impedance	ZID	80	100	125	ohm
MIPI_LVDS Combo IO@ MIPI HS receiver mode	Common-mod voltage HS receive mode	VCMRX(DC)	70	NA	300	mV
	Differential input high threshold	VIDTH	NA	NA	70	mV
	Differential input low threshold	VIDTL	-70	NA	NA	mV
	Single-ended input high voltage	VIHHS	NA	NA	460	mV
	Single-ended input low voltage	VILHS	-40	NA	NA	mV
	Single-ended threshold for HS termination enable	VTERM-EN	NA	NA	450	mV
	Differential input impedance	ZID	80	100	125	ohm
MIPI_LVDS Combo IO@ MIPI LP receiver mode	Logic 1 input voltage	VIH	880	NA	NA	mV
	Logic 0 input voltage, not in ULP State	VIL	NA	NA	550	mV
	Logic 0 input voltage, ULP State	VIL-ULPS	NA	NA	300	mV
	Input hysteresis	VHYST	25	NA	NA	mV
MIPI_LVDS Combo IO@ 1.8V TTL RX mode	Logic 1 input voltage	VIH	1.2	NA	1.58	V
	Logic 0 input voltage, not in ULP State	VIL	NA	NA	0.6	V
	Input hysteresis	VHYST	25	NA	NA	mV

3.4 Electrical Characteristics for General IO

Table 3-4 Electrical Characteristics for Digital General IO

Parameters		Symbol	Test condition	Min	Typ	Max	Unit
Digital GPIO @3.3V	Input leakage current	Ii	Vin = 3.3V or 0V	NA	NA	10	uA
	Tri-state output leakage current	Ioz	Vout = 3.3V or 0V	NA	NA	10	uA
	High level input current	Iih	Vin = 3.3V, pulldown disabled	NA	NA	10	uA
			Vin = 3.3V, pulldown enabled	NA	NA	10	uA

Parameters		Symbol	Test condition	Min	Typ	Max	Unit
	Low level input current	Iil	Vin = 0V, pullup disabled	NA	NA	10	uA
			Vin = 0V, pullup enabled	NA	NA	10	uA
Digital GPIO @1.8V	Input leakage current	Ii	Vin = 1.8V or 0V	NA	NA	10	uA
	Tri-state output leakage current	Ioz	Vout = 1.8V or 0V	NA	NA	10	uA
	High level input current	Iih	Vin = 1.8V, pulldown disabled	NA	NA	10	uA
			Vin = 1.8V, pulldown enabled	NA	NA	10	uA
	Low level input current	Iil	Vin = 0V, pullup disabled	NA	NA	10	uA
			Vin = 0V, pullup enabled	NA	NA	10	uA

Note: VDDO and DVDD are both IO power Supply

3.5 Electrical Characteristics for PLL

Table 3-5 Electrical Characteristics for INT PLL

Parameters		Symbol	Test condition	Min	Typ	Max	Unit
	Input clock frequency(Frac)	F _{in}	F _{in} = FREF @1.8V/0.99V	10	NA	800	MHz
	VCO operating range	F _{vco}	F _{vco} = Fref * FBDIV @3.3V/0.99V	475	NA	1900	MHz
	Output clock frequency	F _{out}	F _{out} = Fvco/POSTDIV @3.3V/0.99V	9	NA	1900	MHz
	Lock time	T _{lt}	@ 3.3V/0.99V, FREF=24M,REFDIV=1	NA	1000	1500	Input clock cycles

Table 3-6 Electrical Characteristics for FRAC PLL

Parameters		Symbol	Test condition	Min	Typ	Max	Unit
	Input clock frequency(Frac)	F _{in}	F _{in} = FREF @1.8V/0.99V	1	NA	1200	MHz
	VCO operating range	F _{vco}	F _{vco} = Fref * FBDIV @3.3V/0.99V	950	NA	3800	MHz
	Output clock frequency	F _{out}	F _{out} = Fvco/POSTDIV @3.3V/0.99V	19	NA	3800	MHz
	Lock time	T _{lt}	@ 3.3V/0.99V, FREF=24M,REFDIV=1	NA	250	500	Input clock cycles

Notes:

- ① REFDIV is the input divider value;
- ② FBDIV is the feedback divider value;
- ③ POSTDIV is the output divider value

3.6 Electrical Characteristics for USB2.0 Interface

Table 3-7 Electrical Characteristics for USB2.0 Interface

Parameters	Symbol	Test condition	Min	Typ	Max	Unit
Transmitter						
Output resistance	ROUT	Classic mode (Vout = 0 or 3.3V)	40.5	45	49.5	ohms
		HS mode (Vout = 0 to 800mV)	40.5	45	49.5	ohms
Output Capacitance	COUT	seen from D+ or D-			3	pF
Output Common Mode Voltage	VM	Classic (LS/FS) mode	1.45	1.65	1.85	V
		HS mode	0.175	0.2	0.225	V
Differential output signal high	VOH	Classic (LS/FS); Io=0mA	2.97	3.3	3.63	V
		Classic (LS/FS); Io=6mA	2.2	2.7	NA	V
		HS mode; Io=0mA	360	400	440	mV
Differential output signal low	VOL	Classic (LS/FS); Io=0mA	-0.33	0	0.33	V
		Classic (LS/FS); Io=6mA	NA	0.3	0.8	V
		HS mode; Io=0mA	-40	0	40	mV

Parameters	Symbol	Test condition	Min	Typ	Max	Unit
Receiver						
Receiver sensitivity	RSENS	Classic mode	NA	+ -250	NA	mV
		HS mode	NA	+ -25	NA	mV
Receiver common mode	RCM	Classic mode	0.8	1.65	2.5	V
		HS mode (differential and squelch comparator)	0.1	0.2	0.3	V
		HS mode (disconnect comparator)	0.5	0.6	0.7	V
Input capacitance (seen at D+ or D-)			NA	NA	3	pF
Squelch threshold			100	NA	150	mV
Disconnect threshold			570	600	664	mV

3.7 Electrical Characteristics for MIPI CSI interface

Table 3-8 HS Receiver AC specifications (for MIPI mode)

Parameters	Symbol	Min	Typ	Max	Unit
Common-mode interference beyond 450 MHz	$\Delta V_{CMRX}(HF)$	NA	NA	100	mV
Common-mode interference 50MHz - 450MHz	$\Delta V_{CMRX}(LF)$	-50	NA	50	mV
Common-mode termination	CCM	NA	NA	60	pF

Table 3-9 LP Receiver AC specifications (for MIPI mode)

Parameters	Symbol	Min	Typ	Max	Unit
Input pulse rejection	eSPIKE	NA	NA	300	V.ps
Minimum pulse width response	TMIN-RX	20	NA	NA	ns
Peak interference amplitude	VINT	NA	NA	200	mv
Interference frequency	fINT	450	NA	NA	MHz

Table 3-10 HS Receiver AC specifications (for LVDS mode)

Parameters	Symbol	Min	Typ	Max	Unit
Common-mode interference beyond 450 MHz	$\Delta V_{CMRX}(HF)$	NA	NA	100	mV
Common-mode interference 50MHz - 450MHz	$\Delta V_{CMRX}(LF)$	-50	NA	50	mV
Common-mode termination	CCM	NA	NA	50	pF

3.8 Electrical Characteristics for Audio CODEC interface

Table 3-11 Electrical Characteristics for Audio CODEC

Test conditions: AVDD = 1.8V, DVDD = 0.8V, TA = 25°C, 1KHz Sine Input, Fs = 48KHz

Parameters	Symbol	Test condition	Min	Typ	Max	Units
Operating Condition						
Analog Supply	AVDD		1.62	1.8	1.98	V
Microphone Bias						
Bias Voltage	V _{MICB}		0.8*AVDD	NA	0.975*AVDD	V
Bias Current	I _{MICB}		NA	NA	3	mA
Microphone Gain Boost PGA						
Programmable Gain	G _{BST}		0	NA	20	dB
Gain Step Size			NA	20	NA	dB
Input Resistance	R _{IN}	G _{BST} =0dB	NA	44	NA	K Ω
		G _{BST} =20dB	NA	8	NA	K Ω
Input Capacitance	C _{IN}		NA	10	NA	pF
ALC PGA						
Programmable Gain	G _{ALC}		-9	NA	37.5	dB
Gain Step Size			NA	1.5	NA	dB

Parameters	Symbol	Test condition	Min	Typ	Max	Units
ADC						
Signal to Noise Ratio	SNR	A-weighted	NA	92	NA	dB
Total Harmonic Distortion	THD	-3dBFS input	NA	-80	NA	dB
Channel Separation			NA	80	NA	dB
Power Supply Rejection	PSRR	1KHz	NA	80	NA	dB
Digital Filter Pass Band Ripple			0.1	0.125	0.125	
DAC Line Output						
Programmable Gain	G _{DRV}		-39	NA	6	dB
Gain Step Size			NA	1.5	NA	dB
Signal to Noise Ratio	SNR	A-weighted	NA	93	NA	dB
Total Harmonic Distortion	THD	-3dBFS output 600Ω load	NA	-84	NA	dB
Power Supply Rejection	PSRR	1KHz	NA	55	NA	dB
Power Consumption						
Standby			NA	0.01	NA	mA
Mono Recording			NA	2.5	NA	mA
Mono Playback		Quiescent output	NA	2.5	NA	mA

3.9 Electrical Characteristics for SARADC

Table 3-12 Electrical Characteristics for SARADC

Parameters	Symbol	Test condition	Min	Typ	Max	Unit
Resolution			NA	10	NA	bit
Effective Number of Bit	ENOB		NA	9	NA	bit
Differential Non-Linearity	DNL		-1	NA	+1	LSB
Integral Non-Linearity	INL		-2	NA	+2	LSB
Reference voltage	VREFP		NA	1.8	NA	V
Input Capacitance	C _{IN}		NA	8	NA	pF
Sampling Rate	f _s		NA	NA	1	MS/s
Spurious Free Dynamic Range	SFDR	f _s =1MS/S f _{OUT} =1.17KHz	NA	61	NA	dB
Signal to Noise and Harmonic Ratio	SNDR		NA	56	NA	dB

3.10 Electrical Characteristics for TSADC

Table 3-13 Electrical Characteristics for TSADC

Parameters	Symbol	Test condition	Min	Typ	Max	Unit
Accuracy from -40°C to 125°C	T _{JACC}		NA	NA	±3	°C
Sensing Temperature Range	T _{RANGE}		-40	NA	125	°C
Resolution	T _{LSB}		NA	0.6	NA	°C

Chapter 4 Thermal Management

4.1 Overview

For reliability and operability concerns, the absolute maximum junction temperature has to be below 125°C.

4.2 Package Thermal Characteristics

Table 4-1 provides the thermal resistance characteristics for the package used on the SoC. The resulting simulation data for reference only, please prevail in kind test.

Table 4-1 Thermal Resistance Characteristics

Parameter	Symbol	Typical	Unit
Junction-to-ambient thermal resistance	θ_{JA}	27.3	(°C/W)
Junction-to-board thermal resistance	θ_{JB}	12.5	(°C/W)
Junction-to-case thermal resistance	θ_{JC}	8.4	(°C/W)

Note: The JEDEC 2S2P PCB is 4 layers, 114.3mm*76.2mm.