

● Features

$V_{DS} = 60V$
 $I_D = 0.3A$
 $R_{DS(ON)} \leq 2\Omega (V_{GS} = 10V)$

● General Description

The TNM3K60FEX uses advanced technology to provide excellent $R_{DS(ON)}$, low gate charge and operation with low gate voltages. This device is suitable for use as a load switch or in PWM applications.

- ROHS compliant
- MSL: 3

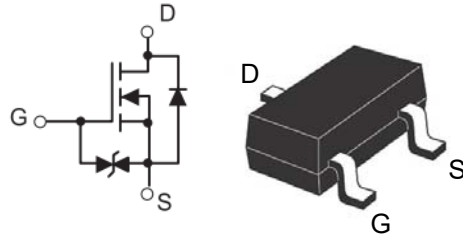
● Pin Configurations

● Package Information

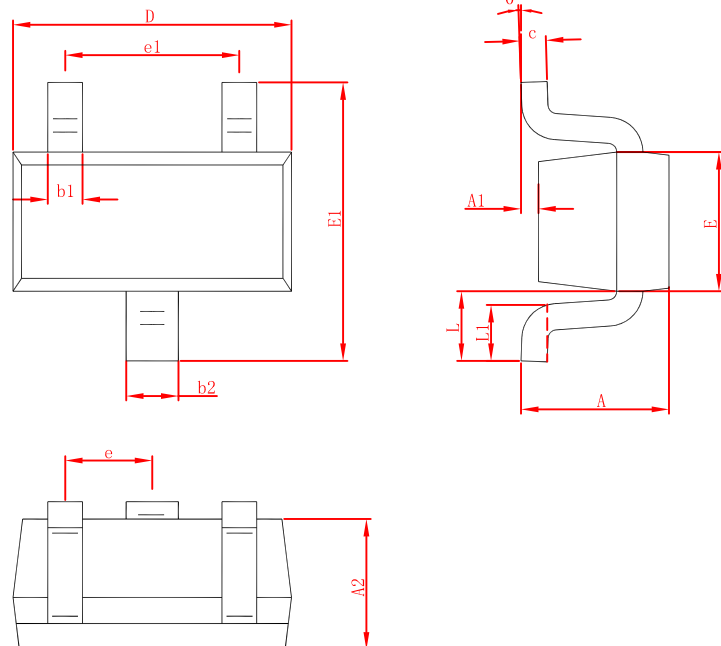
SOT-523



Symbol	Dimensions In Millimeters		Dimensions In Inches	
	Min.	Max.	Min.	Max.
A	0.700	0.900	0.028	0.035
A1	0.000	0.100	0.000	0.004
A2	0.700	0.800	0.028	0.031
b1	0.150	0.250	0.006	0.010
b2	0.250	0.350	0.010	0.014
c	0.100	0.200	0.004	0.008
D	1.500	1.700	0.059	0.067
E	0.700	0.900	0.028	0.035
E1	1.450	1.750	0.057	0.069
e	0.500 TYP.		0.020 TYP.	
e1	0.900	1.100	0.035	0.043
L	0.400 REF.		0.016 REF.	
L1	0.260	0.460	0.010	0.018
θ	0°	8°	0°	8°

● Absolute Maximum Ratings (@T_A=25°C unless otherwise noted)

Parameter	Symbol	Ratings	Unit
Drain-Source Voltage	V _{DSS}	60	V
Gate Source Voltage	V _{GSS}	±20	V
Drain Current (Continuous) *AC	I _D	0.3	A
Drain Current (Pulse) *B	I _{DM}	1.2	A
Power Dissipation	P _D	0.15	W
Operating Temperature/ Storage Temperature	T _J /T _{STG}	-55~150	°C

● Thermal Characteristics

Parameter	Symbol	Ratings	Unit
Thermal Resistance ,Junction-to-Ambient	R _{θJA}	833	°C/W

● Electrical Characteristics (@T_A=25°C unless otherwise noted)

Parameter	Symbol	Test Conditions	Min	Typ	Max	Unit
Drain-Source Breakdown Voltage	V _{(BR)DSS}	V _{GS} =0V, I _D =250uA	60	--	--	V
Zero Gate Voltage Drain Current	I _{DSS}	V _{DS} =48V, V _{GS} =0V	--	--	1	uA
Gate Threshold Voltage	V _{GS(TH)}	V _{DS} =V _{GS} , I _{DS} =250uA	1.1	--	2.1	V
Gate Leakage Current	I _{GSS}	V _{GS} =±20V, V _{DS} =0V	--	--	±10	uA
Drain-Source On-state Resistance	R _{Ds(on)}	V _{GS} =10V, I _D =0.25A	--	--	2.0	Ω
		V _{GS} =4.5V, I _D =0.25A	--	--	2.8	Ω
Total Gate Charge	Q _g	V _{GS} =10V, V _{DD} =30V, I _D =0.3A	--	1.8	--	nC
Turn-on Delay Time	t _{d(on)}	V _{GS} =10V, V _{DD} =30V, I _D =0.3A R _{GEN} =6Ω	--	5.2	--	ns
Turn-off Delay Time	t _{d(off)}		--	16.7	--	ns
Input Capacitance	C _{iss}	V _{GS} =0V, V _{DS} =30V, f=1MHZ	--	16	--	pF
Output Capacitance	C _{oss}		--	10	--	pF
Reverse Transfer Capacitance	C _{rss}		--	5.5	--	pF

A: The value of R_{θJA} is measured with the device mounted on 1in² FR-4 board with 2oz. Copper, in a still air environment with T_A=25°C. The value in any given application depends on the user's specific board design.

B: Repetitive rating, pulse width limited by junction temperature .

C: The current rating is based on the t< 10s junction to ambient thermal resistance rating.



TYPICAL ELECTRICAL AND THERMAL CHARACTERISTICS

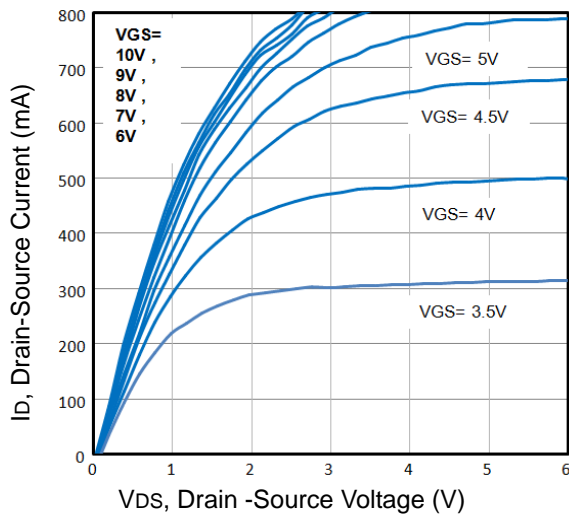

Fig1. Typical Output Characteristics

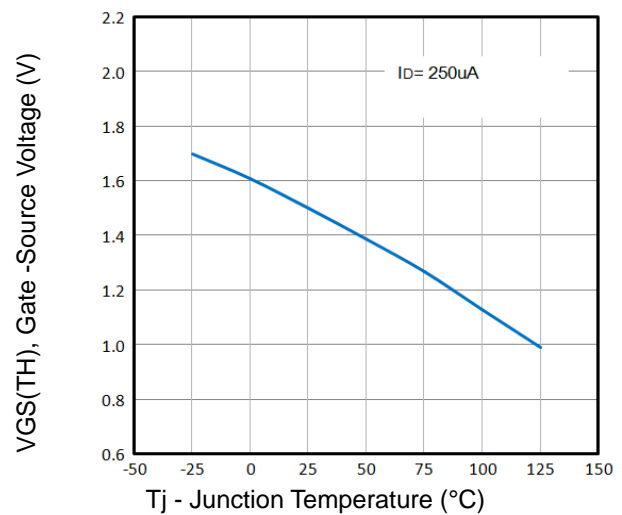

Fig2. Normalized Threshold Voltage Vs. Temperature

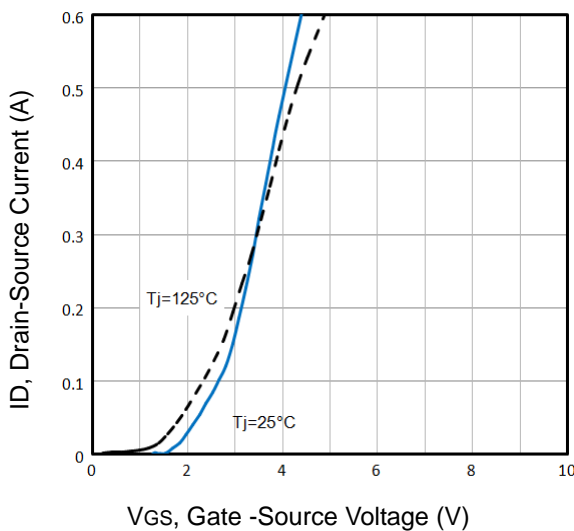

Fig3. Typical Transfer Characteristics

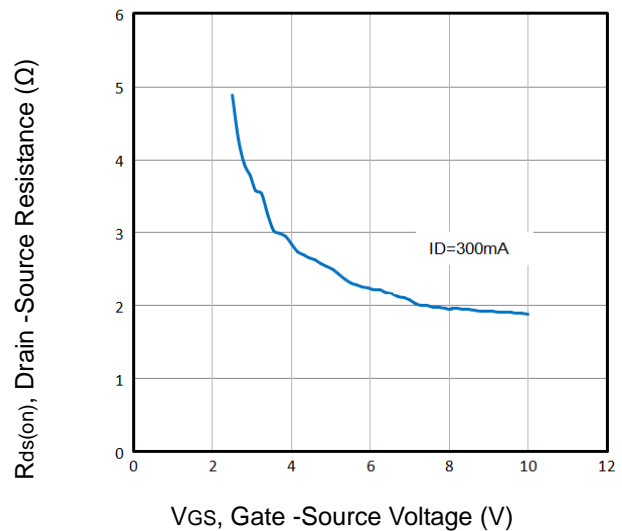

Fig4. Rds(on) vs Gate-Source Voltage

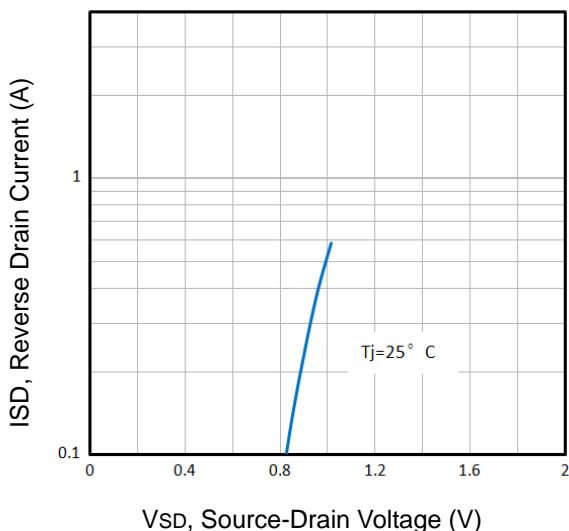

Fig5. Typical Source-Drain Diode Forward Voltage

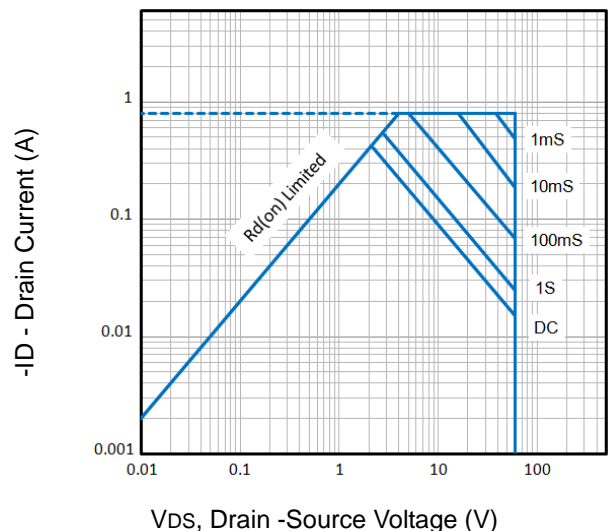

Fig6. Maximum Safe Operating Area

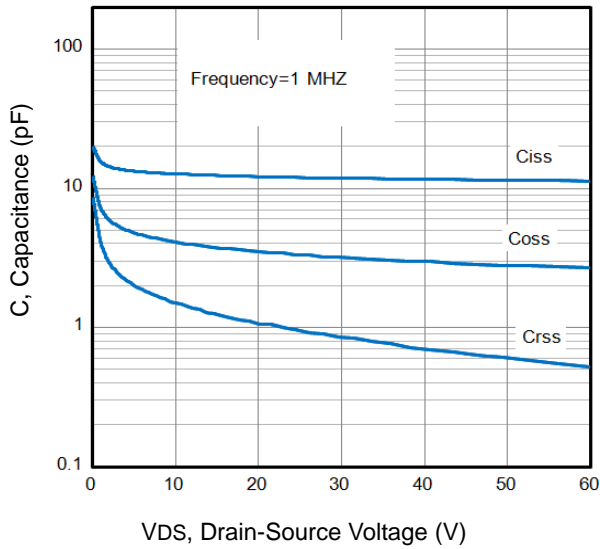

Fig7. Typical Capacitance Vs. Drain-Source Voltage

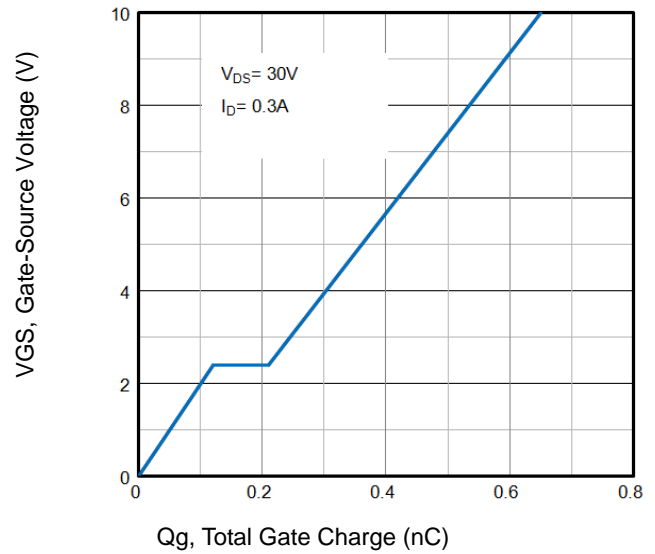

Fig8. Typical Gate Charge Vs. Gate-Source Voltage

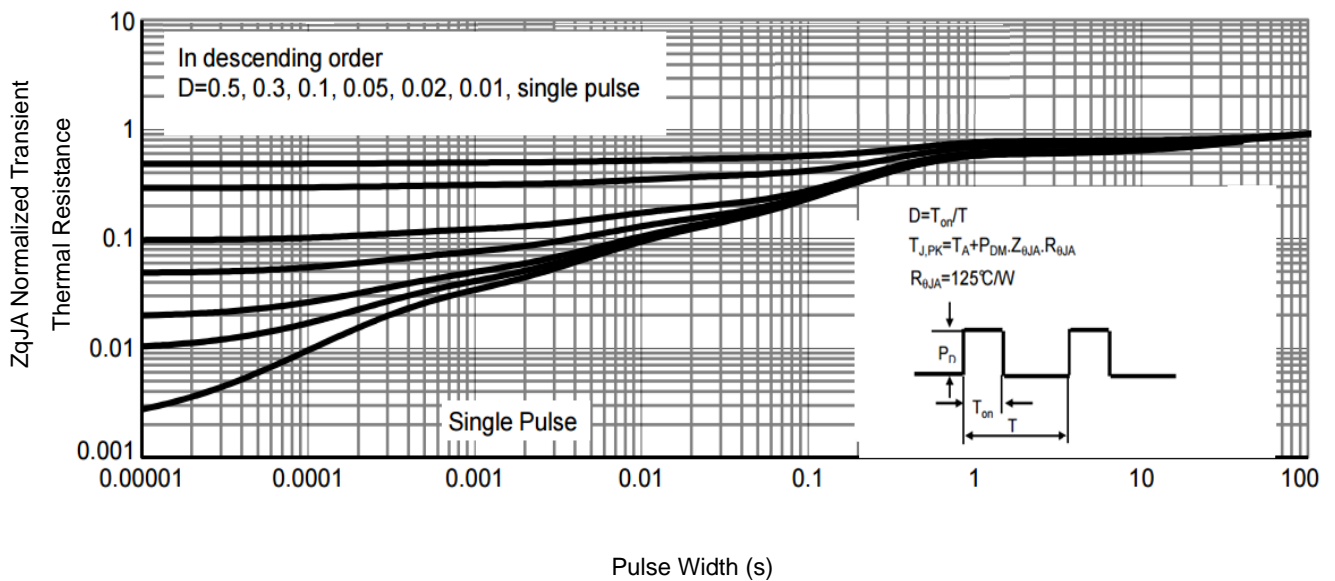
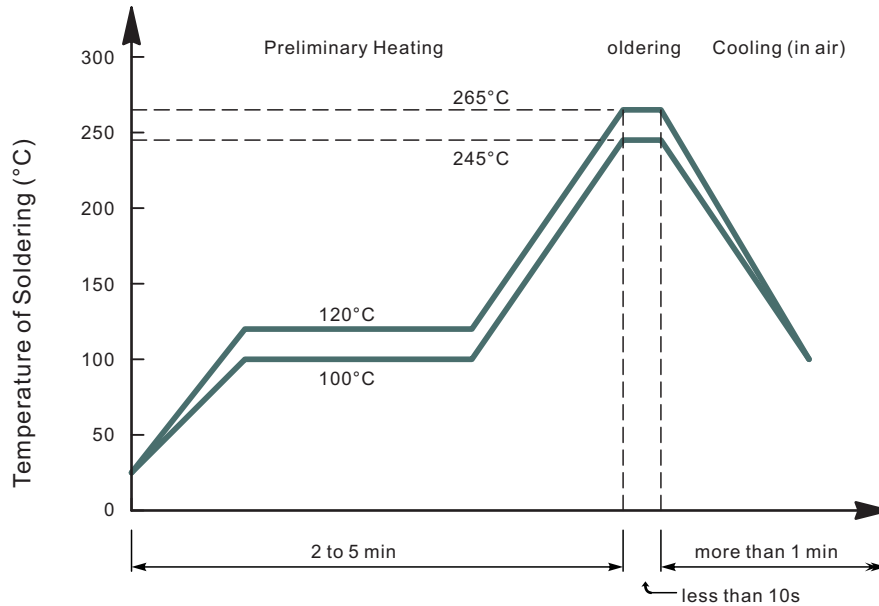

Fig9. Normalized Maximum Transient Thermal Impedance



- Recommended condition of flow soldering



- Recommended condition of reflow soldering

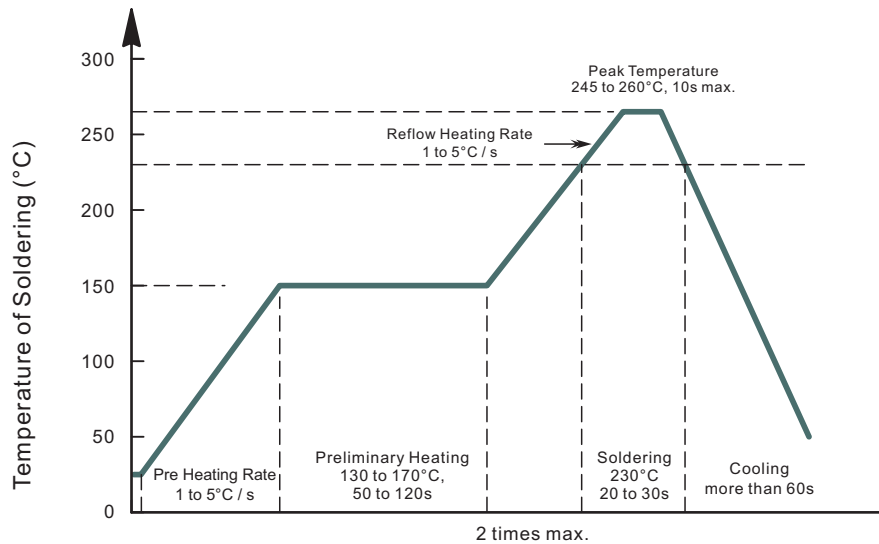

SOT-523 Suggested Pad Layout

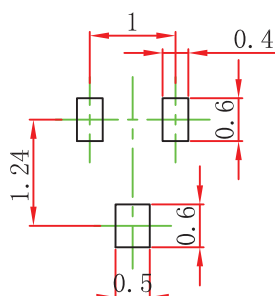

- Note:
- Controlling dimension: in millimeters.
 - General tolerance: ± 0.05 mm.
 - The pad layout is for reference purposes only.



SOT-523 Tape and Reel

SOT-523 Embossed Carrier Tape

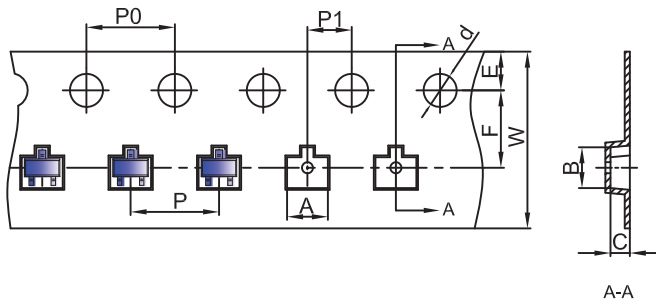

Packaging Description:
 SOT-523 parts are shipped in tape. The carrier tape is made from a dissipative (carbon filled) polycarbonate resin. The cover tape is a multilayer film (Heat Activated Adhesive in nature) primarily composed of polyester film, adhesive layer, sealant, and anti-static sprayed agent. These reeled parts in standard option are shipped with 3,000 units per 7" or 17.8cm diameter reel. The reels are clear in color and is made of polystyrene plastic (anti-static coated).

Dimensions are in millimeter										
Pkg type	A	B	C	d	E	F	P0	P	P1	W
SOT-523	1.85	1.85	0.875	Ø1.50	1.75	3.50	4.00	4.00	2.00	8.00

SOT-523 Reel

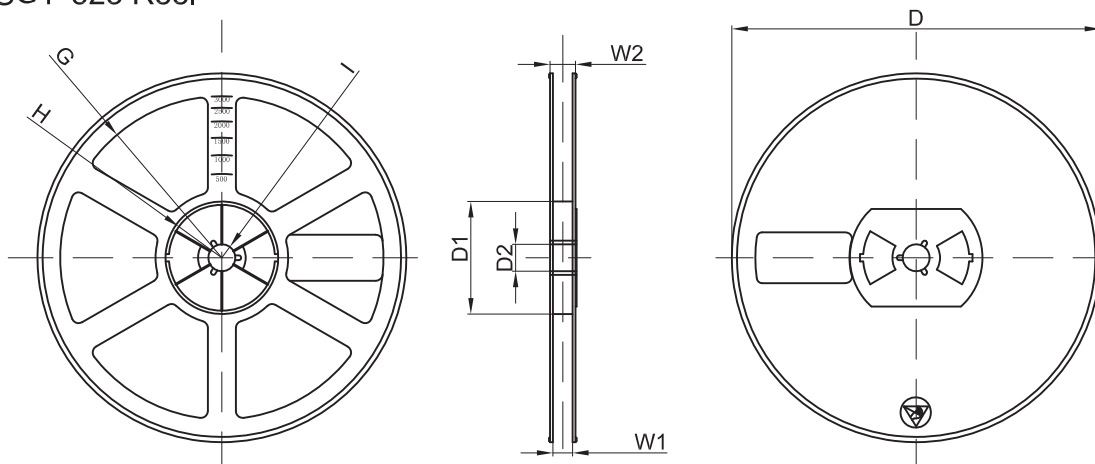

Dimensions are in millimeter								
Reel Option	D	D1	D2	G	H	I	W1	W2
7" Dia	Ø178.00	54.40	13.00	R78.00	R25.60	R6.50	9.50	12.30

REEL	Reel Size	Box	Box Size(mm)	Carton	Carton Size(mm)	G.W.(kg)
3000 pcs	7 inch					