

Features

- ❑ Transient protection for high-speed data lines
 - IEC 61000-4-2 (ESD) ±30kV (Air)
 - ±30kV (Contact)
 - IEC 61000-4-4 (EFT) 40A (5/50 ns)
 - IEC 61000-4-5 (Surge) 25A (8/20μs)
- ❑ Package optimized for high-speed lines
- ❑ Provides protection for two line pairs
- ❑ Low capacitance: 3.8pF @ 0V (Typical)
- ❑ Low leakage current: 0.1μA @ V_{RWM} (Typical)
- ❑ Low operating and clamping voltage
- ❑ Each I/O pin can withstand over 1000 ESD strikes for ±8kV contact discharge

Description

TS3314PLX is a low-capacitance Transient Voltage Suppressor (TVS) array designed to provide electrostatic discharge (ESD) protection for high-speed data interfaces. With typical capacitance of 3.8 pF only, TS3314PLX is designed to protect parasitic-sensitive systems against over-voltage and over-current transient events. It complies with IEC 61000-4-2 (ESD), Level 4 (±15kV air, ±8kV contact discharge), IEC 61000-4-4 (electrical fast transient - EFT) (40A, 5/50 ns), IEC 61000-4-5 (Surge) (25A, 8/20μs), very fast charged device model (CDM) ESD and cable discharge event (CDE), etc.

TS3314PLX is in a SOT23-5L package . Each TS3314PLX device can protect two high-speed line pairs. The combined features of low capacitance and high ESD robustness make TS3314PLX ideal for high-speed data port and high-frequency line (e.g., Gigabit Ethernet Ports) applications. The low clamping voltage of the TS3314PLX guarantees a minimum stress on the protected IC.

Applications

- ❑ 10/100/1000M Ethernet Ports
- ❑ WAN/LAN Equipment
- ❑ Desktops, Servers and Notebooks
- ❑ Cellular Phones
- ❑ Switching Systems
- ❑ Audio/Video Inputs

Mechanical Characteristics

- ❑ SOT23-5L package
- ❑ Flammability Rating: UL 94V-0
- ❑ Marking: Part number, Date
- ❑ Packaging: Tape and Reel

Circuit Diagram

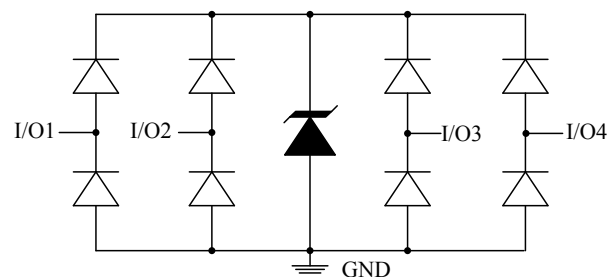

Pin Configuration

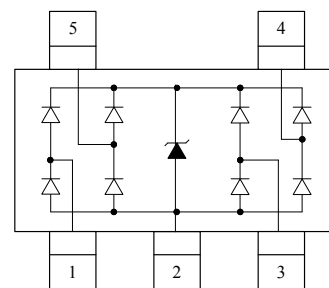

SOT23-5L
(Top View)



Absolute Maximum Rating

Symbol	Parameter	Value	Units
I_{PP}	Peak Pulse Current (8/20 μ s)	25	A
P_{PK}	Peak Pulse Power (8/20 μ s)	450	Watts
V_{ESD}	ESD per IEC 61000-4-2 (Air) ESD per IEC 61000-4-2 (Contact)	± 30 ± 30	kV
T_{OPT}	Operating Temperature	-55 to +125	$^{\circ}$ C
T_{STG}	Storage Temperature	-55 to +150	$^{\circ}$ C

Electrical Characteristics (T = 25 $^{\circ}$ C)

Symbol	Parameter
V_{RWM}	Nominal Reverse Working Voltage
I_R	Reverse Leakage Current @ V_{RWM}
V_{t1}	Trigger Voltage
I_{t1}	Trigger Current @ V_{t1}
V_h	Holding Voltage
I_h	Holding Current @ V_h
V_C	Clamping Voltage @ I_{PP}
I_{PP}	Maximum Peak Pulse Current
V_F	Forward Voltage @ I_F
C_{ESD}	Parasitic Capacitance

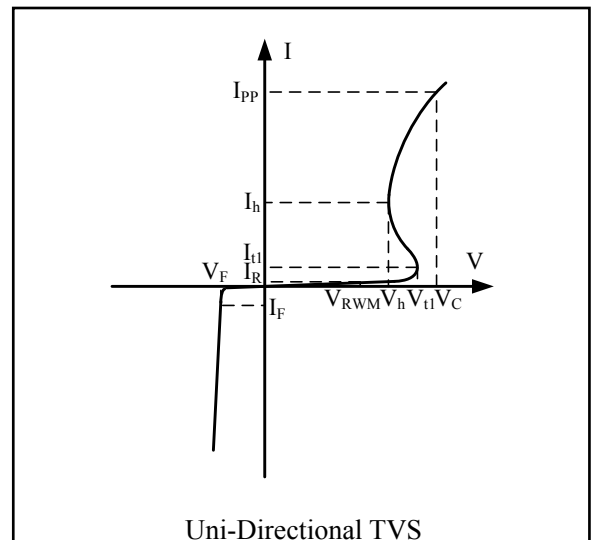

Symbol	Test Condition	Minimum	Typical	Maximum	Units
V_{RWM}				3.3	V
I_R	$V_{RWM} = 3.3V, T = 25^{\circ}C$		0.1	1.0	μ A
V_{t1}	$I_{t1} = 1mA$	3.5	4.2	5.0	V
V_h	$I_h = 90mA$	1.5		3.5	V
V_C	$I_{PP} = 1A, t_p = 8/20\mu s$ (Each Line)			5.5	V
V_C	$I_{PP} = 10A, t_p = 8/20\mu s$ (Each Line)			10.0	V
V_C	$I_{PP} = 25A, t_p = 8/20\mu s$ (Each Line)			16.0	V
R_{DYN}	Dynamic Resistance Between I/O Pins and Ground		0.3		Ohms
C_{ESD}	Between I/O Pins and Ground $V_R = 0V, f = 1MHz$		3.8	5.0	pF
C_{ESD}	Between I/O Pins $V_R = 0V, f = 1MHz$		2.0	2.5	pF



8/20µs Pulse Waveform

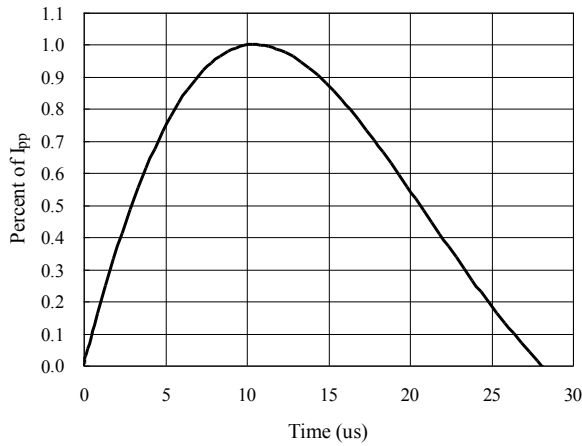

Clamping Voltage V_C vs. Current I_{PP}

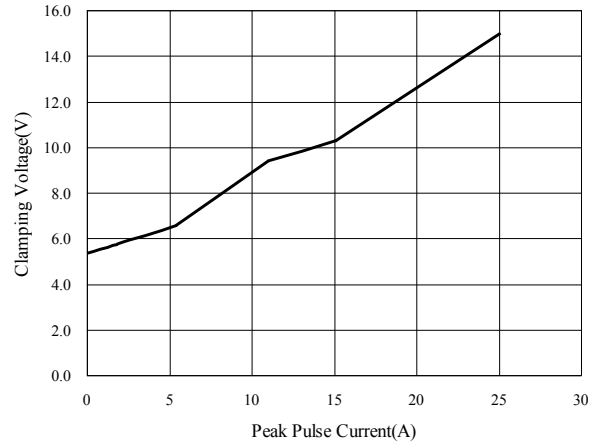

Insertion Loss S21

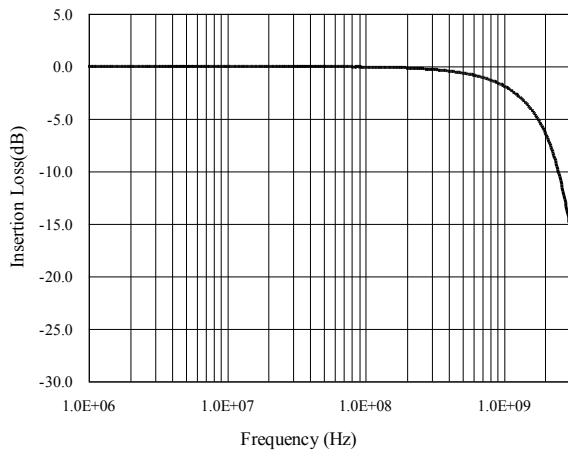

Normalized Capacitance vs. Voltage

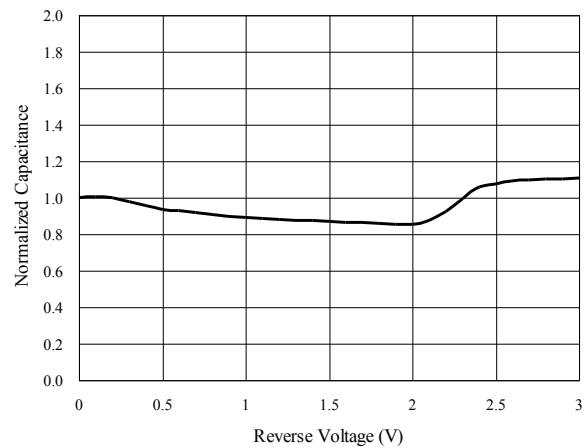

ESD Clamping of I/O to GND (+8kV Contact per IEC 61000-4-2)

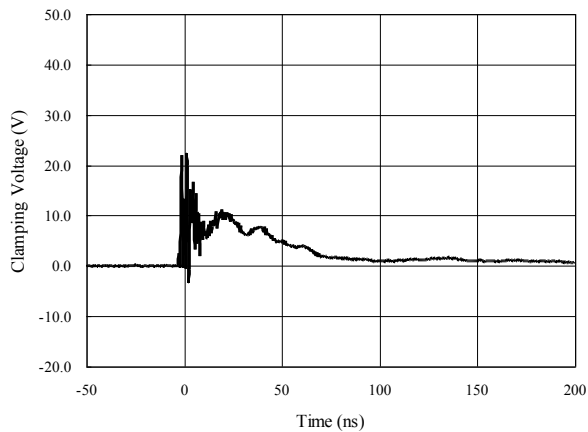

ESD Clamping of I/O to GND (-8kV Contact per IEC 61000-4-2)

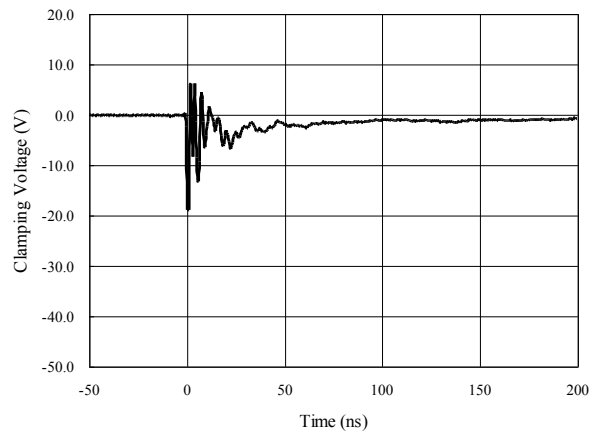

Application Information

Electronic equipment is susceptible to damage caused by a variety of sources, including Electrostatic Discharge (ESD), Electrical Fast Transients (EFT) and Lightning strikes. The TS3314PLX was designed to protect the sensitive equipment from damage which may be induced by such transient events. This product can be configured in different connections to meet the requirement of common-mode and differential-mode as follows:

Gigabit Ethernet Protection

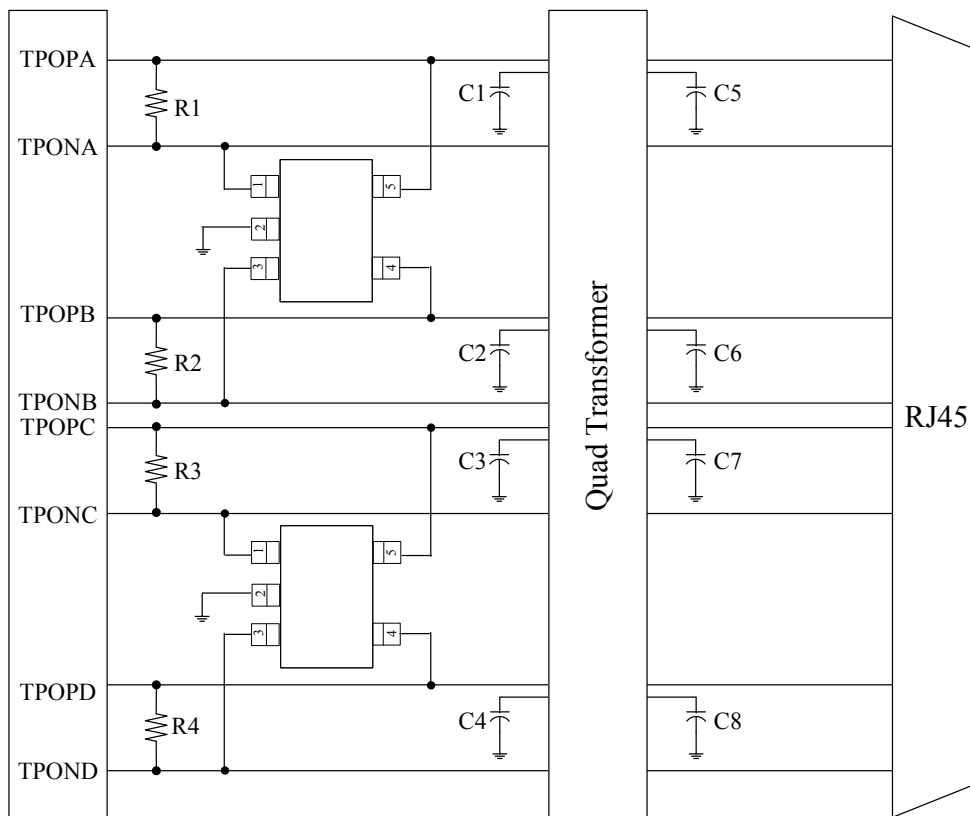

Schematic Diagram for Gigabit Ethernet ESD/Surge Protection using TS3314PLX

NOTE:

Please connect pin2 to the Ground plane of systems .



PACKAGE DIMENSIONS (SOT23-5L)

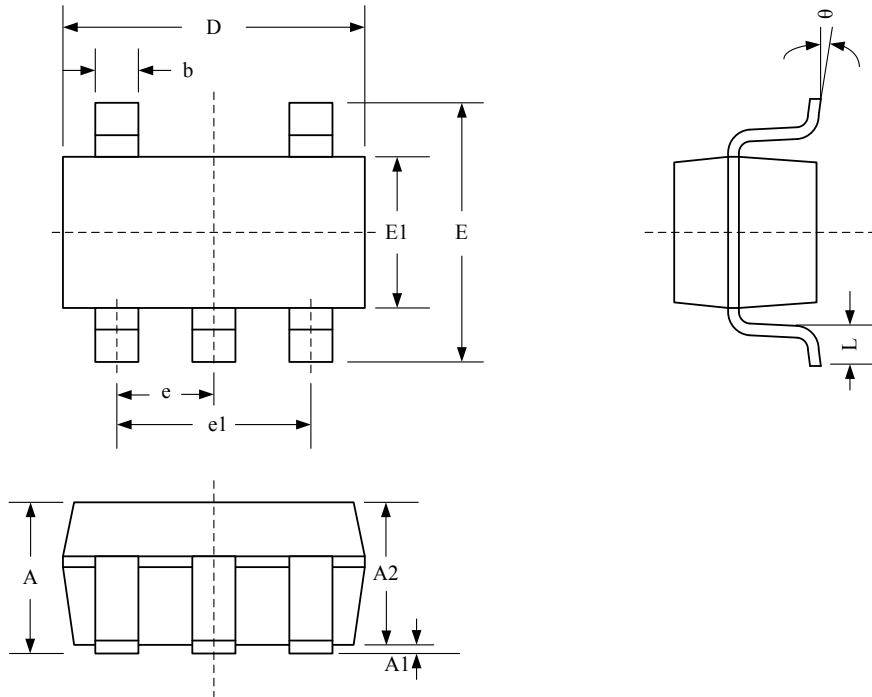

Package Dimensions (Controlling dimensions are in millimeters)

Symbol	Dimensions (mm)			Dimensions (Inches)		
	Minimum	Typical	Maximum	Minimum	Typical	Maximum
A	—	—	1.450	—	—	0.057
A1	0.000	—	0.150	0.000	—	0.006
A2	—	—	1.300	—	—	0.012
b	0.300	—	0.500	0.012	—	0.020
D	2.90 BSC			0.114 BSC		
e	0.95 BSC			0.037 BSC		
e1	1.90 BSC			0.075 BSC		
E	2.80 BSC			0.110 BSC		
E1	1.60 BSC			0.063 BSC		
L	0.300	0.450	0.600	0.012	0.018	0.024
θ	0°	4°	8°	0°	4°	8°



Tape and Reel Specification (SOT23-5L)

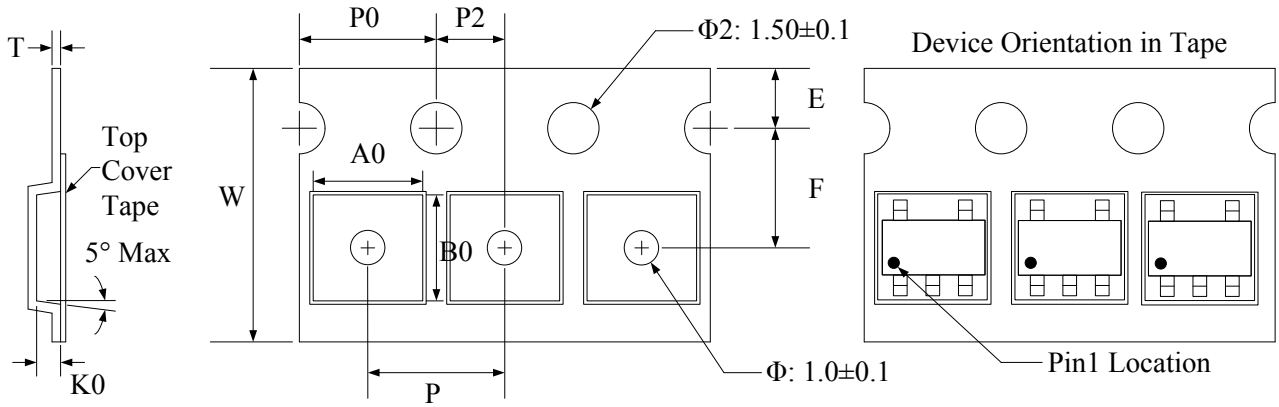

Symbol	W	A0	B0	K0	E	F	P	P0	P2	T
Dimensions (mm)	8.00+0.3 -0.1	3.23±0.05	3.17±0.05	1.37±0.05	1.75±0.1	3.5±0.05	4.0±0.1	4.0±0.1	2.0±0.05	0.25±0.02

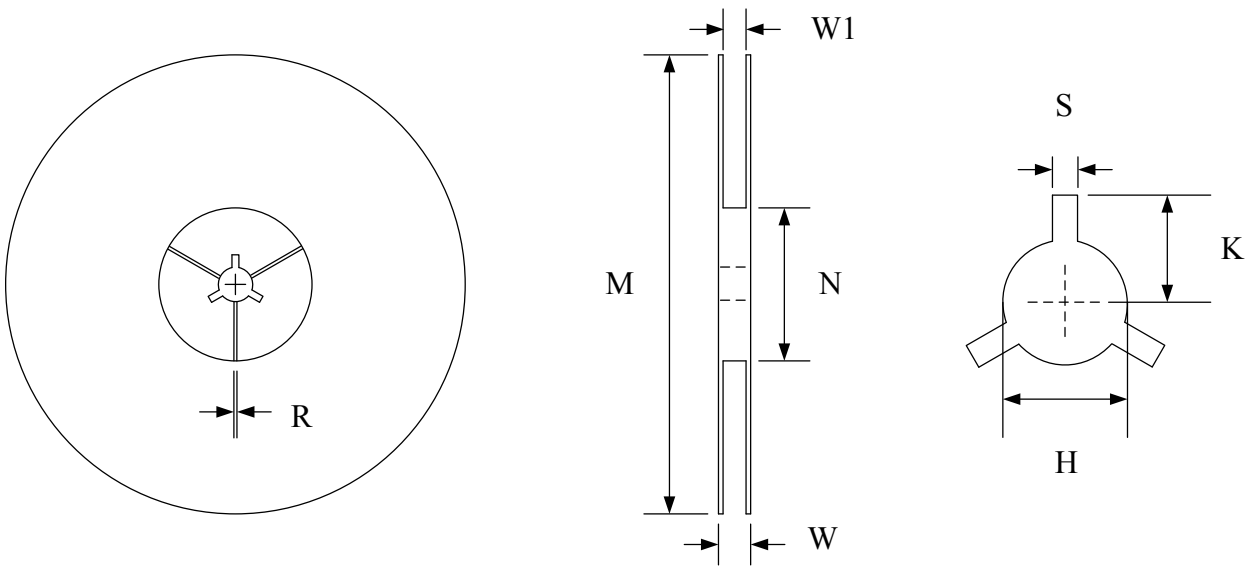

Symbol	Reel Size	M	N	W	W1	H	S	K	R
Dimensions (mm)	Φ178	178.0±1.0	60.0±1.0	11.5±0.5	9.0±0.5	13.0±0.5	2.0±0.1	11.0±0.2	1.0±0.05

Marking Codes

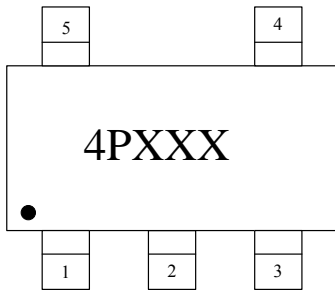

Or

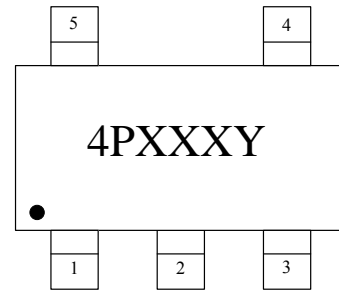

Note:

- (1) “4P” is part number, fixed.
- (2) “XXX” is internal code.

Note:

- (1) “4P” is part number, fixed.
- (2) “XXX” is the last 3 characters of the wafer's Lot No., “Y” is the internal code.

Ordering Information

Part Number	Working Voltage	Quantity Per Reel	Reel Size
TS3314PLX	3.3V	3,000	7 Inch