



DESCRIPTION

IC HMAX232ECDR is purposed for application in high-performance information processing systems and control devices of wide application. Input voltage levels are compatible with standard CMOS levels.

APPLICATIONS

- Portable Computers
- Battery-Powered RS-232 Systems
- Interface Translation
- Low-Power Modems
- Terminals

FEATURES

- Output voltage levels are compatible with input levels of C-MOS, N-MOS and TTL integrated circuits.
- Supply voltage range from 2.0 to 6.0 V.
- Low input current: 1.0 mA; 0.1 mA at T = 25 °C.
- Output current 24 mA.
- Latching current not less than 450 mA at T = 25°C
- Tolerable value of static potential not less than 2000V

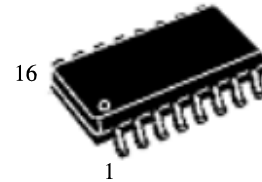

SOP-16

FUNCTION TABLE

INPUT (RIN, TIN)	OUTPUT (ROUT, TOUT)
L (Low Level)	H (High Level)
H (High Level)	L (Low Level)

ABSOLUTE MAXIMUM RATINGS

PARAMETER	SYMBOL	MIN.	MAX.	UNIT
Supply Voltage	V_{CC}	-0.3	6.0	V
Transmitter High Output Voltage	V_+	$V_{CC}-0.3$	14	V
Transmitter Low Output Voltage	V_-	-0.3	-14	V
Transmitter Input Voltage	V_{TIN}	-0.3	$V_++0.3$	V
Receiver Input Voltage	V_{RIN}	-30	30	V
Voltage Applied to Transmitter Output	V_{TOUT}	$V_- - 0.3$	$V_++0.3$	V
Voltage Applied to Receiver Output	V_{ROUT}	-0.3	$V_{CC}+0.3$	V
Storage Temperature Range	T_{STG}	-65	150	°C



PIN CONFIGURATION

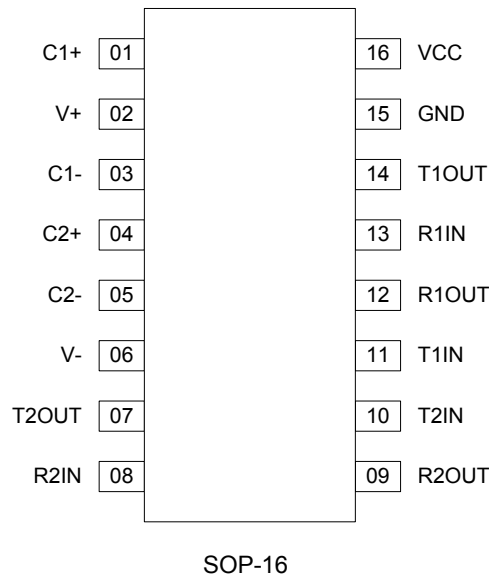

PIN DESCRIPTION

Pin No.	Pin Name	Pin Description
1	C1+	Terminal for Positive Charge-Pump C1 Capacitor
2	V+	Positive Voltage Generated by the Charge-Pump
3	C1-	Terminal for Negative Charge-Pump C1 Capacitor
4	C2+	Terminal for Positive Charge-Pump C2 Capacitor
5	C2-	Terminal for Negative Charge-Pump C2 Capacitor
6	V-	Negative Voltage Generated by the Charge-Pump
7	T2OUT	RS-232 Driver Output (Levels RS-232)
8	R2IN	RS-232 Receiver Input (Levels RS-232)
9	R2OUT	RS-232 Receiver Output (Levels TTL/CMOS)
10	T2IN	RS-232 Driver Input (Levels TTL/CMOS)
11	T1IN	RS-232 Driver Input (Levels TTL/CMOS)
12	R1OUT	RS-232 Receiver Output (Levels TTL/CMOS)
13	R1IN	RS-232 Receiver Input (Levels RS-232)
14	T1OUT	RS-232 Driver Output (Levels RS-232)
15	GND	Ground
16	VCC	Supply Voltage Input



RECOMMENDED OPERATING CONDITIONS

PARAMETER	SYMBOL	MIN.	MAX.	UNIT
Supply Voltage	V_{CC}	4.5	5.5	V
Transmitter Input Voltage	V_{TIN}	0	V_{CC}	V
Receiver Input Voltage	V_{RIN}	-30	30	V
Output Current of Transmitter Short Circuit	I_{SC}	-	± 60	mA
Ambient Temperature Range	T_A	-40	+85	$^{\circ}C$

TYPICAL APPLICATION CIRCUIT

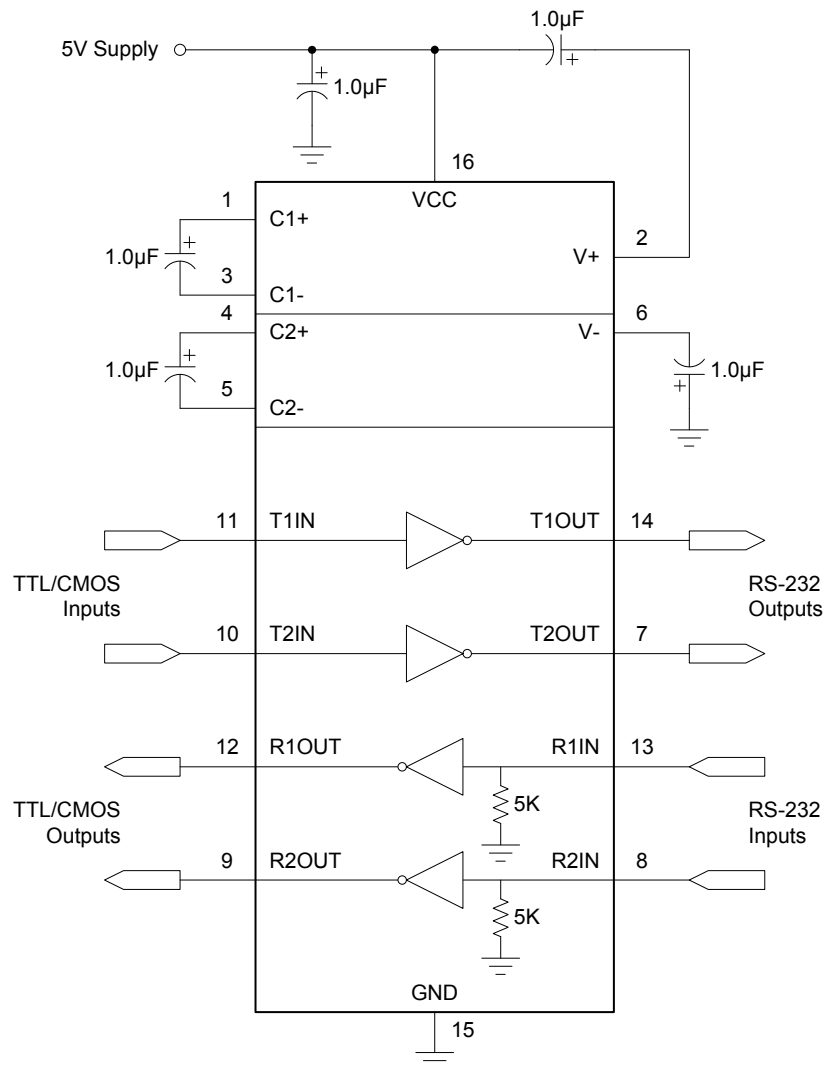



ELECTRICAL CHARACTERISTICS

(Limits in standard typeface are for $T_A=25^{\circ}\text{C}$, and the limits in boldface type apply over full operating temperature range.)

PARAMETER	SYMBOL	TEST CONDITIONS	MIN.	TYP.	MAX.	UNIT	
Supply Current	I_{CC}	$V_{CC} = 5.5\text{V}$ $V_{IL} = 0\text{V}$	-	-	10.0 14.0	mA	
Receiver Parameters							
Hysteresis Voltage	V_h	$V_{CC} = 5.0\text{V}$	0.2 0.2	-	0.9 1.0	V	
On (Operation) Voltage	V_{on}	$V_O \leq 0.1\text{V}$, $I_{OL} \leq 20\mu\text{A}$	-	-	2.4 2.3	V	
Off (Dropout) Voltage	V_{off}	$V_O \geq V_{CC} - 0.1\text{V}$ $I_{OH} \leq -20\mu\text{A}$	0.8 0.9	-	-	V	
Output Low Voltage	V_{OL}	$I_L = 3.2\text{mA}$, $V_{CC} = 4.5\text{V}$, $V_{IH} = 2.4\text{V}$	-	-	0.3 0.4	V	
Output High Voltage	V_{OH}	$I_{OH} = -1.0\text{mA}$, $V_{CC} = 4.5\text{V}$, $V_{IL} = 0.8\text{V}$	3.6 3.5	-	-	V	
Input Resistance	R_i	$V_{CC} = 5.0\text{V}$	3.0 3.0	-	7.0 7.0	k Ω	
Transmitter Parameters							
Output Low Voltage	V_{OL}	$V_{CC} = 4.5\text{V}$, $V_{IH} = 2.0\text{V}$, $R_L = 3.0\text{k}\Omega$	-	-	-5.2 -5.0	V	
Output High Voltage	V_{OH}	$V_{CC} = 4.5\text{V}$, $V_{IL} = 0.8\text{V}$, $R_L = 3.0\text{k}\Omega$	5.2 5.0	-	-	V	
Input Low Current	I_{iL}	$V_{CC} = 5.5\text{V}$, $V_{iL} = 0\text{V}$	-	-	-1.0 -10.0	μA	
Input High Current	I_{iH}	$V_{CC} = 5.5\text{V}$, $V_{iH} = V_{CC}$	-	-	1.0 10.0	μA	
Speed Of Output Front Charge	SR	$V_{CC} = 5.0\text{V}$, $C_L = 50 - 1000\text{pF}$, $R_L = 3.0 - 7.0\text{k}\Omega$	3.0 2.7	-	30 27	V/ μs	
Output Resistance	R_O	$V_{CC} = V^+ = V^- = 0\text{V}$ $V_O = \pm 2\text{V}$	350 300	-	-	Ω	
Short Circuit Output Current	I_{SC}	$V_{CC} = 5.5\text{V}$ $V_O = 0\text{V}$	$V_i = V_{CC}$	-	-	-50 -60	mA
			$V_i = 0$	-	-	50 60	
Speed Of Information Transmission	ST	$V_{CC} = 4.5\text{V}$, $C_L = 1000\text{pF}$, $R_L = 3.0\text{k}\Omega$, $t_w = 7\mu\text{s}$ (for extreme, $t_w = 8\mu\text{s}$)	140 120	-	-	kbit/s	
Dynamic Parameters							
Signal Propagation Delay Time When Switching On (Off)	t_{PHLR} (t_{PLHR})	$V_{CC} = 4.5\text{V}$, $C_L = 150\text{pF}$, $V_{iL} = 0\text{V}$, $V_{iH} = 3.0\text{V}$, $t_{LH} = t_{HL} \leq 10\text{ns}$	-	-	9.7 10.0	μs	
Signal Propagation Delay Time When Switching On (Off)	t_{PHLT} (t_{PLHT})	$V_{CC} = 4.5\text{V}$, $C_L = 2500\text{pF}$, $V_{iL} = 0\text{V}$, $V_{iH} = 3.0\text{V}$, $R_L = 3\text{k}\Omega$, $t_{LH} = t_{HL} \leq 10\text{ns}$	-	-	5.0 6.0	μs	



Capacitance

Symbol	Parameter	V_{CC} , V	Rate	Unit
C_{IN}	Input capacitance	5.0	9.0	pF
C_{PD}	Dynamic capacitance		90	

Timing diagram when measuring IC dynamic parameters

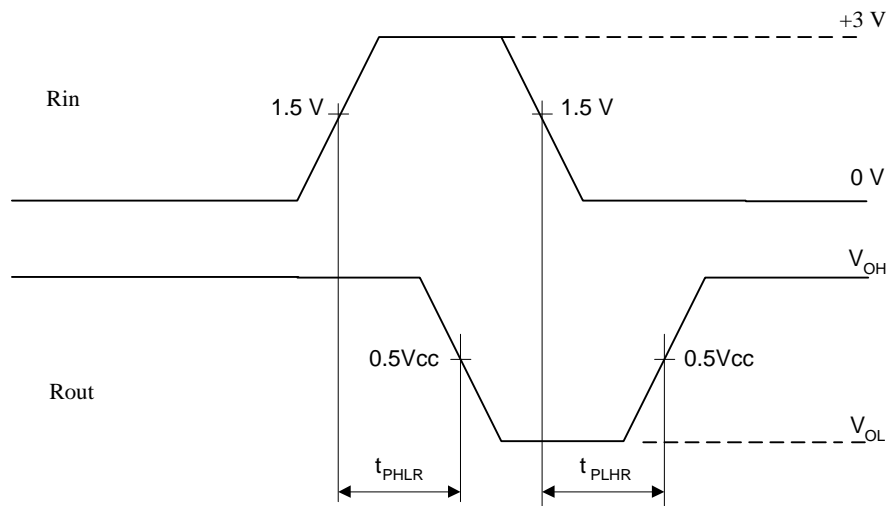

Figure 1

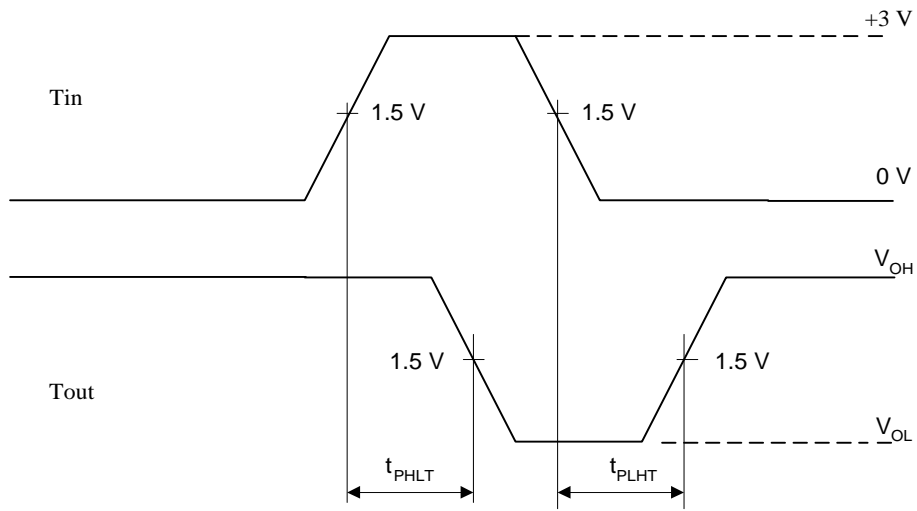

Figure 2

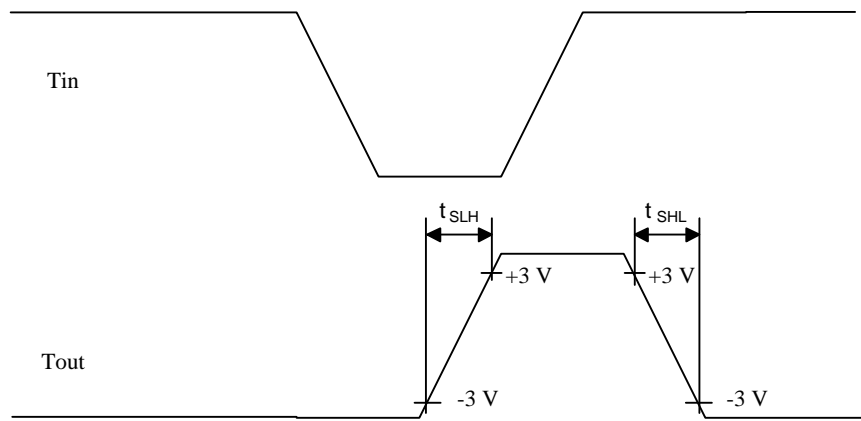

Figure 3

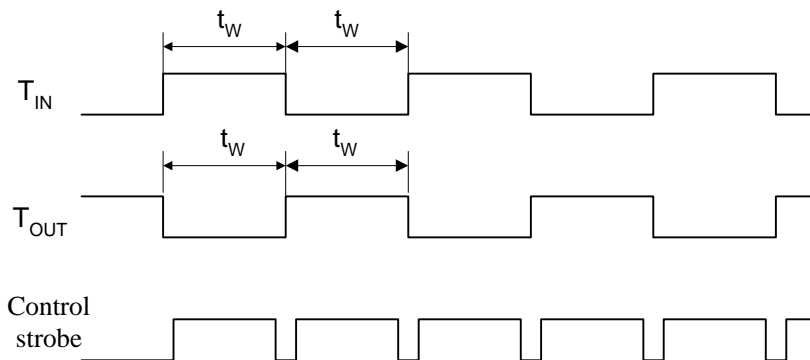
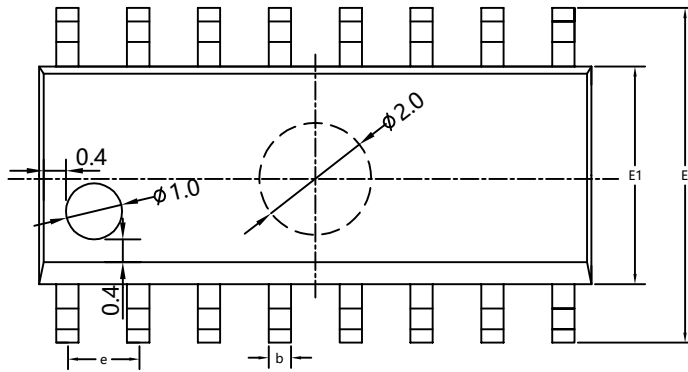
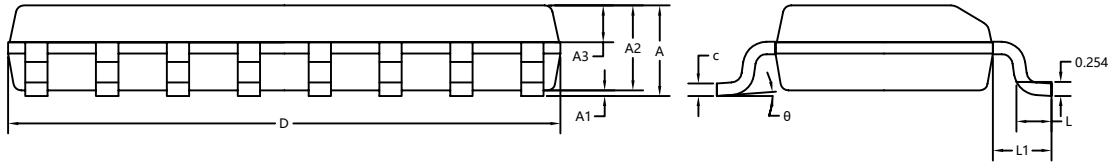

Figure 4



PACKAGE OUTLINE DIMENSIONS
SOP-16



SYMBOL	MILLIMETER		
	MIN	NOM	MAX
A	1.50	1.60	1.70
A1	0.10	0.15	0.25
A2	1.40	1.45	1.50
A3	0.60	0.65	0.70
b	0.30	0.40	0.50
c	0.15	0.20	0.25
D	9.80	9.90	10.00
E	5.80	6.00	6.20
E1	3.85	3.90	3.95
e	1.27BSC		
L	0.50	0.60	0.70
L1	1.05BSC		
theta	0°	4°	8°



Attention

- Any and all HUA XUAN YANG ELECTRONICS products described or contained herein do not have specifications that can handle applications that require extremely high levels of reliability, such as life-support systems, aircraft's control systems, or other applications whose failure can be reasonably expected to result in serious physical and/or material damage. Consult with your HUA XUAN YANG ELECTRONICS representative nearest you before using any HUA XUAN YANG ELECTRONICS products described or contained herein in such applications.
- HUA XUAN YANG ELECTRONICS assumes no responsibility for equipment failures that result from using products at values that exceed, even momentarily, rated values (such as maximum ratings, operating condition ranges, or other parameters) listed in products specifications of any and all HUA XUAN YANG ELECTRONICS products described or contained herein.
- Specifications of any and all HUA XUAN YANG ELECTRONICS products described or contained herein stipulate the performance, characteristics, and functions of the described products in the independent state, and are not guarantees of the performance, characteristics, and functions of the described products as mounted in the customer's products or equipment. To verify symptoms and states that cannot be evaluated in an independent device, the customer should always evaluate and test devices mounted in the customer's products or equipment.
- HUA XUAN YANG ELECTRONICS CO.,LTD. strives to supply high-quality high-reliability products. However, any and all semiconductor products fail with some probability. It is possible that these probabilistic failures could give rise to accidents or events that could endanger human lives, that could give rise to smoke or fire, or that could cause damage to other property. When designing equipment, adopt safety measures so that these kinds of accidents or events cannot occur. Such measures include but are not limited to protective circuits and error prevention circuits for safe design, redundant design, and structural design.
- In the event that any or all HUA XUAN YANG ELECTRONICS products(including technical data, services) described or contained herein are controlled under any of applicable local export control laws and regulations, such products must not be exported without obtaining the export license from the authorities concerned in accordance with the above law.
- No part of this publication may be reproduced or transmitted in any form or by any means, electronic or mechanical, including photocopying and recording, or any information storage or retrieval system, or otherwise, without the prior written permission of HUA XUAN YANG ELECTRONICS CO.,LTD.
- Information (including circuit diagrams and circuit parameters) herein is for example only ; it is not guaranteed for volume production. HUA XUAN YANG ELECTRONICS believes information herein is accurate and reliable, but no guarantees are made or implied regarding its use or any infringements of intellectual property rights or other rights of third parties.
- Any and all information described or contained herein are subject to change without notice due to product/technology improvement, etc. When designing equipment, refer to the "Delivery Specification" for the HUA XUAN YANG ELECTRONICS product that you intend to use.