



Product Description

The HOPA348 (single), HOPA2348 (dual) and HOPA4348 (quad) are low voltage micro power CMOS voltage feedback operational amplifiers. With an excellent bandwidth of 1.3MHz, a slew rate of 0.9V/ μ s, and a quiescent current of 70 μ A per amplifier at 5V, the OPAx348 family can be designed into a wide range of applications.

The HOPAx348 op-amps are specifically designed for general-purpose applications with optimal performance. They have a wide input common-mode voltage range and excellent output voltage swings, and the maximum input offset voltage are 2.5mV. These parts provide rail-to-rail output swing into heavy loads.

The HOPAx348 family is specified for single or dual power supplies of +2.1V to +5.5V. All models are specified over the extended industrial temperature range of -40°C to +125°C.

Features

- High Gains of >102 dB for Active Filters and Gain Stages
- Low Offset Voltage: 2.5 mV Maximum with 2 μ V/°C Low Drift
- Gain-Bandwidth Product: 1.3MHz
- High Slew Rate: 0.9 V/ μ s
- Low Power: 70 μ A per Amplifier Supply Current
- Settling Time to 0.1% with 2V Step: 4.1 μ s
- Unity Gain Stable
- Very Low Input Bias Current: 1pA
- Rail-to-Rail Input and Output
 - Input Voltage Range: -0.2 to +5.2 V at 5V Supply
- Operating Power Supply: +2.1 to +5.5 V
- Operating Temperature Range: -40°C to +125°C
- ESD Rating: HBM – 4kV, CDM – 2kV

Applications

- Smoke/Gas/Environment Sensors
- Audio Outputs
- Active Filters
- ASIC Input or Output Amplifier
- Sensor Interfaces
- Portable Equipment
- Battery-Powered Instrumentation

Pin Configurations (Top View)

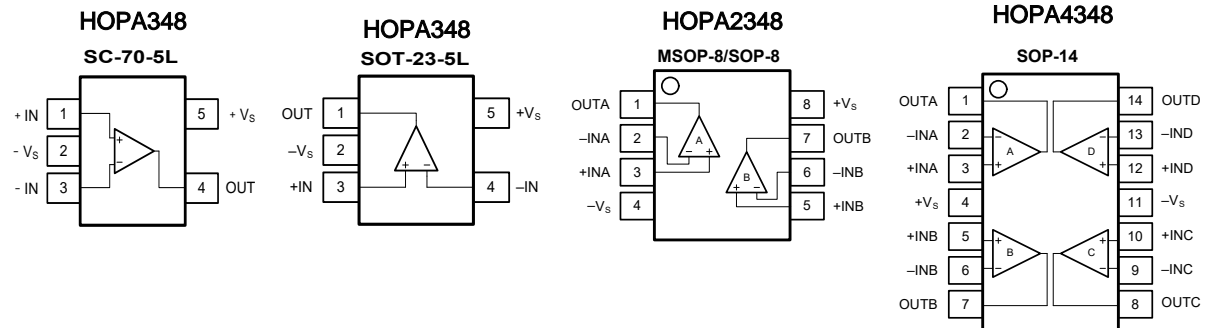



Pin Description

Symbol	Description
-IN	Inverting input of the amplifier. The voltage range can go from $(V_{S-}-0.2V)$ to $(V_{S+}+0.2V)$.
+IN	Non-inverting input of the amplifier. This pin has the same voltage range as -IN.
+Vs	Positive power supply. The voltage is from 2.1V to 5.5V. Split supplies are possible as long as the voltage between V_{S+} and V_{S-} is between 2.1V and 5.5V. A bypass capacitor of 0.1 μ F as close to the part as possible should be used between power supply pins or between supply pins and ground.
-Vs	Negative power supply. It is normally tied to ground. It can also be tied to a voltage other than ground as long as the voltage between V_{S+} and V_{S-} is from 2.1V to 5.5V. If it is not connected to ground, by pass it with a capacitor of 0.1 μ F as close to the part as possible.
OUT	Amplifier output.
N/C	No internal connection.

Limiting Value

In accordance with the Absolute Maximum Rating System (IEC 60134).

Parameter	Absolute Maximum Rating
Supply Voltage, V_{S+} to V_{S-}	10.0V
Common-Mode Input Voltage	$V_{S-}-0.5V$ to $V_{S+}+0.5V$
Storage Temperature Range	-65°C to +150°C
Junction Temperature	160°C
Lead Temperature Range (Soldering 10 sec)	260°C
Electrostatic Discharge Voltage	HBM \pm 4000V
	CDM \pm 2000V
	MM \pm 400V

Ordering Information

Type Number	Package Name	Package Quantity
HOPA348AIDCKR	SC-70-5L	Tape and Reel, 3000
HOPA348AIDBVR	SOT-23-5L	Tape and Reel, 3000
HOPA2348AIDGKR	MSOP-8	Tape and Reel, 3 000
HOPA2348AIDR	SOP-8	Tape and Reel, 3 000
HOPA4348AIDR	SOP-14	Tape and Reel, 2 500



Electrical Characteristics

$V_S = 5.0V$, $T_A = +25^\circ C$, $V_{CM} = V_S/2$, $V_O = V_S/2$, and $R_L = 10k\Omega$ connected to $V_S/2$, unless otherwise noted.
Boldface limits apply over the specified temperature range, $T_A = -40$ to $+125^\circ C$.

Symbol	Parameter	Conditions	Min.	Typ.	Max.	Unit
INPUT CHARACTERISTICS						
V_{OS}	Input offset voltage		-2.5	± 0.5	+2.5	mV
	over Temperature		-2.8		+2.8	
V_{OSTC}	Offset voltage drift	over Temperature		2		$\mu V/^\circ C$
I_B	Input bias current			1		pA
	over Temperature				800	
I_{OS}	Input offset current			1		pA
V_{CM}	Common-mode voltage range		$V_{S-} - 0.2$		$V_{S+} + 0.2$	V
CMRR	Common-mode rejection ratio	$V_{CM} = 0.05V$ to $3.5V$	80	97		dB
	over Temperature		70			
		$V_{CM} = V_{S-} - 0.1$ to $V_{S+} + 0.1 V$	70	82		
	over Temperature		66			
A_{VOL}	Open-loop voltage gain	$R_L = 10k\Omega$, $V_O = 0.05$ to $3.5 V$	102	116		dB
	over Temperature		90			
		$R_L = 2k\Omega$, $V_O = 0.15$ to $3.5 V$	93	108		
	over Temperature		82			
R_{IN}	Input resistance		100			G Ω
C_{IN}	Input capacitance	Differential		2.0		pF
		Common mode		3.5		
OUTPUT CHARACTERISTICS						
V_{OH}	High output voltage swing	$R_L = 10k\Omega$		$V_{S+} - 5$		mV
		$R_L = 600\Omega$		$V_{S+} - 75$		
V_{OL}	Low output voltage swing	$R_L = 10k\Omega$		5		mV
		$R_L = 600\Omega$		75		
Z_{OUT}	Closed-loop output impedance	$f = 200kHz$, $G = +1$		0.4		Ω
	Open-loop output impedance	$f = 1MHz$, $I_O = 0$		2.6		
I_{SC}	Short-circuit current	Source current through 10Ω		45		mA
		Sink current through 10Ω		45		
DYNAMIC PERFORMANCE						
GBW	Gain bandwidth product	$f = 1kHz$		1.3		MHz
Φ_M	Phase margin	$C_L = 100pF$		66		$^\circ$
SR	Slew rate	$G = +1$, $C_L = 100pF$, $V_O = 1.5V$ to $3.5V$		0.9		V/ μs
t_s	Settling time	To 0.1%, $G = +1$, 2V step		4.1		μs
		To 0.01%, $G = +1$, 2V step		5.1		
THD+N	Total harmonic distortion + noise	$f = 1kHz$, $G = +1$, $V_O = 3V_{PP}$		0.0018		%



Symbol	Parameter	Conditions	Min.	Typ.	Max.	Unit
<i>NOISE PERFORMANCE</i>						
V_n	Input voltage noise	$f = 0.1$ to 10 Hz		8		$\mu\text{V}_{\text{P-P}}$
e_n	Input voltage noise density	$f = 1$ kHz		27		$\text{nV}/\sqrt{\text{Hz}}$
I_n	Input current noise density	$f = 1$ kHz		4		$\text{fA}/\sqrt{\text{Hz}}$
<i>POWER SUPPLY</i>						
V_s	Operating supply voltage		2.1		5.5	V
PSRR	Power supply rejection ratio	$V_s = 2.7\text{V}$ to 5.5V , $V_{\text{CM}} < V_{\text{S+}} - 2\text{V}$	82	102		dB
	over Temperature		75			
I_q	Quiescent current (per amplifier)			70	110	μA
	over Temperature				125	
<i>THERMAL CHARACTERISTICS</i>						
T_A	Operating temperature range		-40		+125	$^{\circ}\text{C}$
θ_{JA}	Package Thermal Resistance	SC-70-5L		333		$^{\circ}\text{C}/\text{W}$
		SOT-23-5L		190		
		MSOP-8		216		
		SOP-8		125		
		SOP-14		115		



Typical Performance Characteristics

At $T_A = +25^\circ\text{C}$, $V_{CM} = V_S/2$, and $R_L = 10\text{k}\Omega$ connected to $V_S/2$, unless otherwise noted.

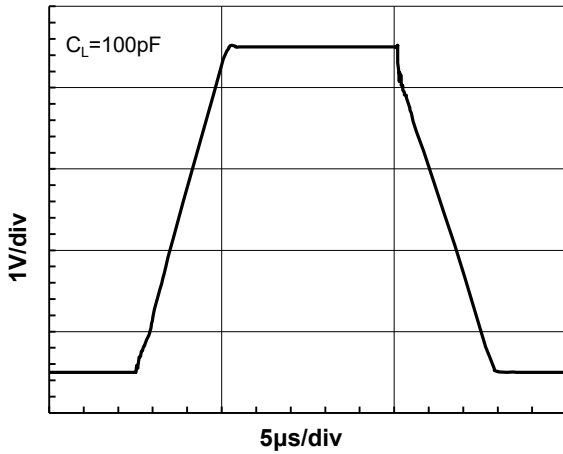

Large Signal Step Response.

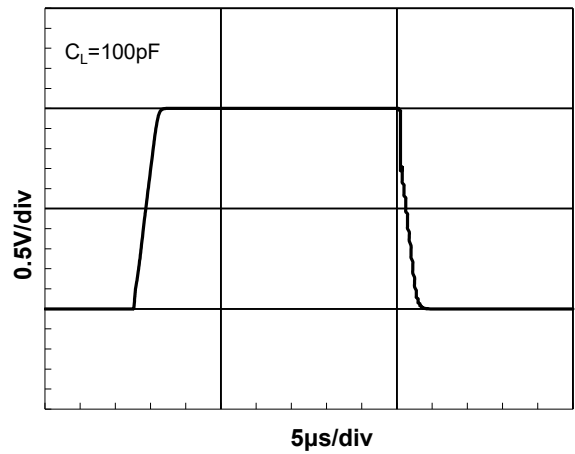

Small Signal Step Response.

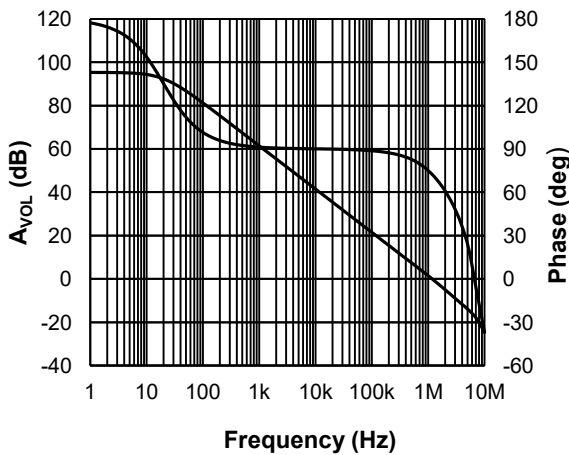

Open-loop Gain and Phase as a function of Frequency.

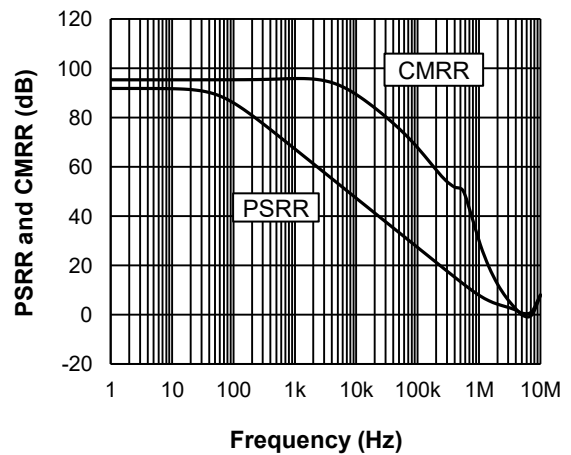

Power Supply and Common-mode Rejection Ratio as a function of Frequency.

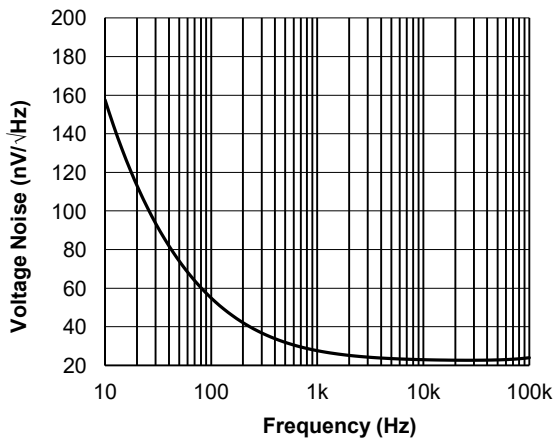

Input Voltage Noise Spectral Density as a function of Frequency.

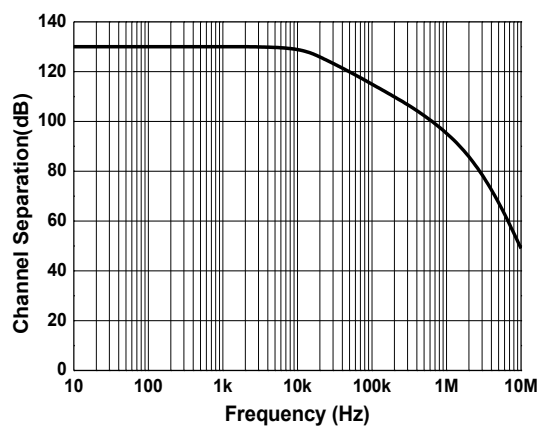

Channel Separation as a function of Frequency.

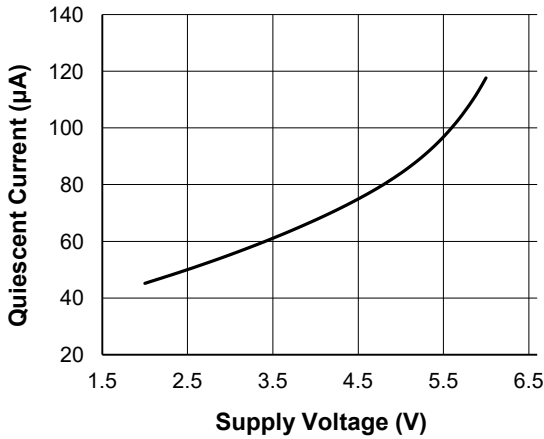

Quiescent Current as a function of Supply Voltage.

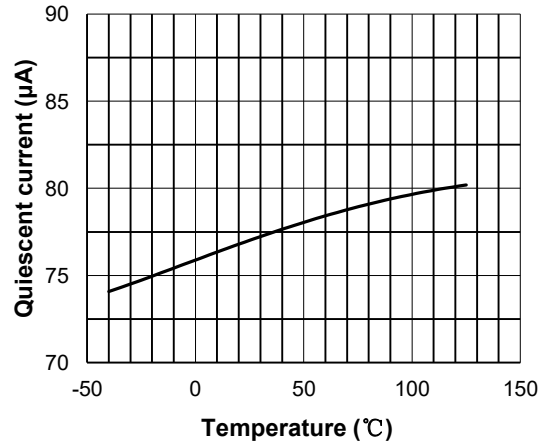

Quiescent Current as a function of Temperature.

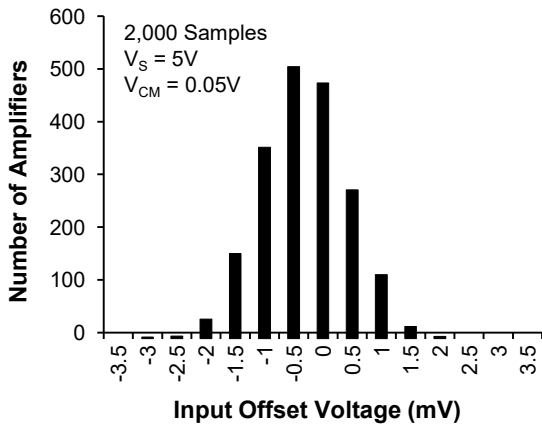

Input Offset Voltage Production Distribution.

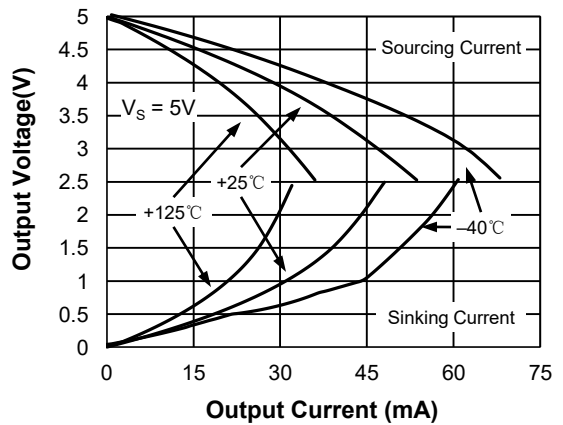

Output Voltage Swing as a function of Output Current.

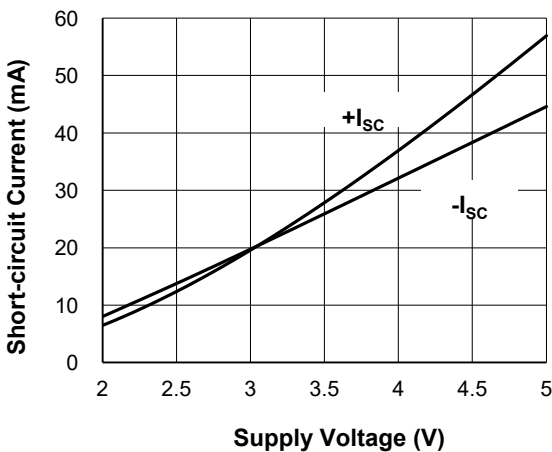

Short-circuit Current as a function of Supply Voltage.

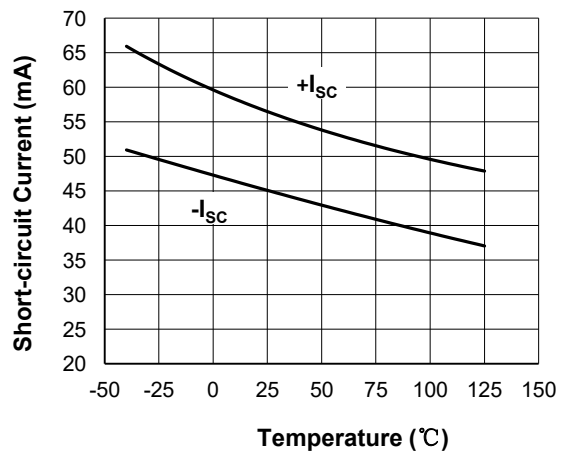

Short-circuit Current as a function of Temperature.



Application Notes

LOW INPUT BIAS CURRENT

The HOPAx348 family is a CMOS op-amp family and features very low input bias current in pA range. The low input bias current allows the amplifiers to be used in applications with high resistance sources. Care must be taken to minimize PCB Surface Leakage. See below section on “PCB Surface Leakage” for more details.

PCB SURFACE LEAKAGE

In applications where low input bias current is critical, Printed Circuit Board (PCB) surface leakage effects need to be considered. Surface leakage is caused by humidity, dust or other contamination on the board. Under low humidity conditions, a typical resistance between nearby traces is $10^{12}\Omega$. A 5V difference would cause 5pA of current to flow, which is greater than the HOPAx348's input bias current at +25°C ($\pm 1\text{fA}$, typical). It is recommended to use multi-layer PCB layout and route the op-amp's -IN and +IN signal under the PCB surface.

The effective way to reduce surface leakage is to use a guard ring around sensitive pins (or traces). The guard ring is biased at the same voltage as the sensitive pin. An example of this type of layout is shown in Figure 1 for Inverting Gain application.

1. For Non-Inverting Gain and Unity-Gain Buffer:
 - a) Connect the non-inverting pin (+IN) to the input with a wire that does not touch the PCB surface.
 - b) Connect the guard ring to the inverting input pin (-IN). This biases the guard ring to the Common Mode input voltage.
2. For Inverting Gain and Trans-impedance Gain Amplifiers (convert current to voltage, such as photo detectors):
 - a) Connect the guard ring to the non-inverting input pin (+IN). This biases the guard ring to the same reference voltage as the op-amp (e.g., $V_S/2$ or ground).
 - b) Connect the inverting pin (-IN) to the input with a wire that does not touch the PCB surface.

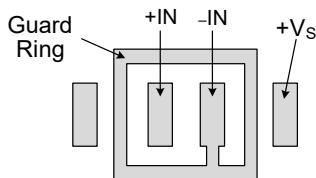

Figure 1. Use a guard ring around sensitive pins

GROUND SENSING AND RAIL TO RAIL

The input common-mode voltage range of the HOPAx348 series extends 200mV beyond the supply rails. This is achieved with a complementary input stage—an N-channel input differential pair in parallel with a P-channel differential pair. For normal operation, inputs should be limited to this range. The absolute maximum input voltage is 500mV beyond the supplies. Inputs greater than the input common-mode range but less than the maximum input voltage, while not valid, will not cause any damage to the op-amp. Unlike some other op-amps, if input current is limited, the inputs may go beyond the supplies without phase inversion, as shown in Figure 2. Since the input common-mode range extends from $(V_{S-} - 0.2\text{V})$ to $(V_{S+} + 0.2\text{V})$, the HOPAx348 op-amps can easily perform 'true ground' sensing. A topology of class AB output stage with common-source transistors is used to achieve rail-to-rail output. For light resistive loads (e.g. 100k Ω), the output voltage can typically swing to within 5mV from the supply rails. With moderate resistive loads (e.g. 10k Ω), the output can typically swing to within 10mV from the supply rails and maintain high open-loop gain. See the Typical Characteristic curve, Output Voltage Swing as a function of Output Current, for more information.

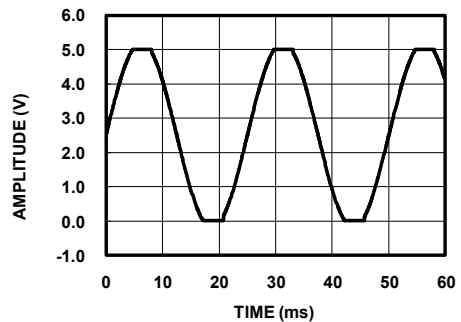

Figure 2. No Phase Inversion with Inputs Greater Than the Power-Supply Voltage

The maximum output current is a function of total supply voltage. As the supply voltage to the amplifier increases, the output current capability also increases. Attention must be paid to keep the junction temperature of the IC below 150°C when the output is in continuous short-circuit. The output of the amplifier has reverse-biased ESD diodes connected to each supply. The output should not be forced more than 0.5V beyond either supply, otherwise current will flow through these diodes.



CAPACITIVE LOAD AND STABILITY

The HOPAx348 can directly drive 1nF in unity-gain without oscillation. The unity-gain follower (buffer) is the most sensitive configuration to capacitive loading. Direct capacitive loading reduces the phase margin of amplifiers and this results in ringing or even oscillation. Applications that require greater capacitive drive capability should use an isolation resistor between the output and the capacitive load like the circuit in Figure 3. The isolation resistor R_{ISO} and the load capacitor C_L form a zero to increase stability. The bigger the R_{ISO} resistor value, the more stable V_{OUT} will be. Note that this method results in a loss of gain accuracy because R_{ISO} forms a voltage divider with the R_L .

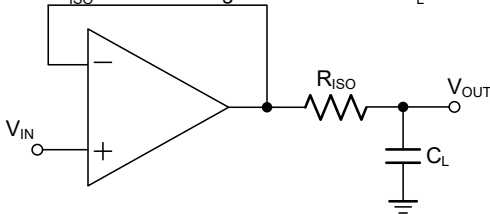

Figure 3. Indirectly Driving Heavy Capacitive Load

An improvement circuit is shown in Figure 4. It provides DC accuracy as well as AC stability. The R_F provides the DC accuracy by connecting the inverting signal with the output. The C_F and R_{ISO} serve to counteract the loss of phase margin by feeding the high frequency component of the output signal back to the amplifier's inverting input, thereby preserving phase margin in the overall feedback loop.

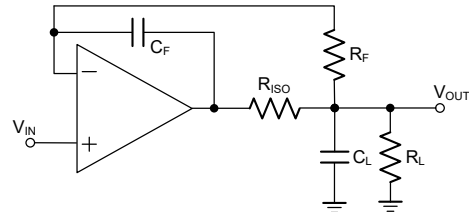

Figure 4. Indirectly Driving Heavy Capacitive Load with DC Accuracy

For no-buffer configuration, there are two others ways to increase the phase margin: (a) by increasing the amplifier's gain, or (b) by placing a capacitor in parallel with the feedback resistor to counteract the parasitic capacitance associated with inverting node.

POWER SUPPLY LAYOUT AND BYPASS

The HOPAx348 family operates from either a single +2.1V to +5.5V supply or dual $\pm 1.05V$ to $\pm 2.75V$ supplies. For single-supply operation, bypass the power supply V_S with a ceramic capacitor (i.e. 0.01 μF to 0.1 μF) which should be placed close (within 2mm for good high frequency performance) to the V_S pin. For dual-supply operation, both the V_{S+} and the V_{S-} supplies should be bypassed to ground with separate 0.1 μF ceramic capacitors.

A bulk capacitor (i.e. 2.2 μF or larger tantalum capacitor) within 100mm to provide large, slow currents and better performance. This bulk capacitor can be shared with other analog parts.

Good PC board layout techniques optimize performance by decreasing the amount of stray capacitance at the op-amp's inputs and output. To decrease stray capacitance, minimize trace lengths and widths by placing external components as close to the device as possible. Use surface-mount components whenever possible. For the op-amp, soldering the part to the board directly is strongly recommended. Try to keep the high frequency big current loop area small to minimize the EMI (electromagnetic interfacing).

GROUNDING

A ground plane layer is important for the HOPAx348 circuit design. The length of the current path speed currents in an inductive ground return will create an unwanted voltage noise. Broad ground plane areas will reduce the parasitic inductance.

INPUT-TO-OUTPUT COUPLING

To minimize capacitive coupling, the input and output signal traces should not be parallel. This helps reduce unwanted positive feedback.



Typical Application Circuits

DIFFERENTIAL AMPLIFIER

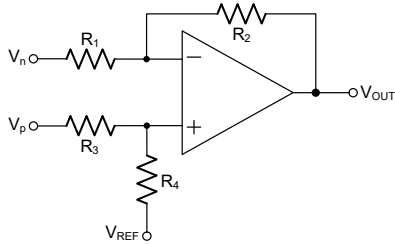

Figure 5. Differential Amplifier

The circuit shown in Figure 5 performs the difference function. If the resistor ratios are equal $R_4/R_3 = R_2/R_1$, then:

$$V_{OUT} = (V_p - V_n) \times R_2/R_1 + V_{REF}$$

INSTRUMENTATION AMPLIFIER

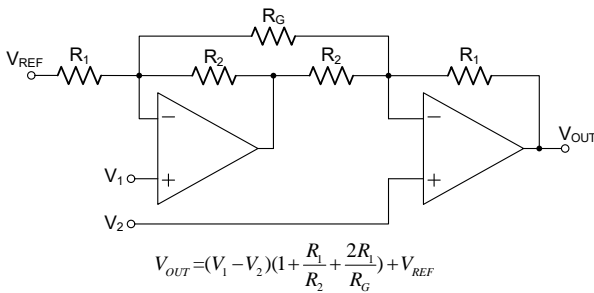
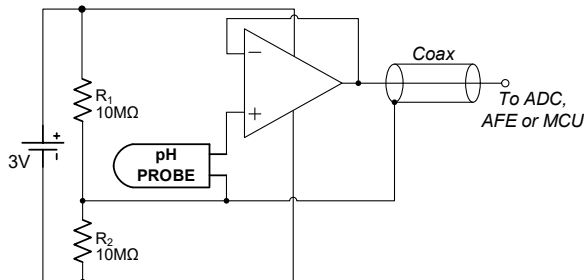

Figure 6. Instrumentation Amplifier

The HOPAx348 family is well suited for conditioning sensor signals in battery-powered applications. Figure 6 shows a two op-amp instrumentation amplifier, using the HOPAx348 op-amps. The circuit works well for applications requiring rejection of common-mode noise at higher gains. The reference voltage (V_{REF}) is supplied by a low-impedance source. In single voltage supply applications, the V_{REF} is typically $V_S/2$.

BUFFERED CHEMICAL SENSORS



All components contained within the pH probe

Figure 7. Buffered pH Probe

The HOPAx348 family has input bias current in the pA range.

This is ideal in buffering high impedance chemical sensors, such as pH probes. As an example, the circuit in Figure 7 eliminates expansive low-leakage cables that that is required to connect a pH probe (general purpose combination pH probes, e.g Corning 476540) to metering ICs such as ADC, AFE and/or MCU. A HOPAx348 op-amp and a lithium battery are housed in the probe assembly. A conventional low-cost coaxial cable can be used to carry the op-amp's output signal to subsequent ICs for pH reading.

SHUNT-BASED CURRENT SENSING AMPLIFIER

The current sensing amplification shown in Figure 8 has a slew rate of $2\pi fV_{PP}$ for the output of sine wave signal, and has a slew rate of $2fV_{PP}$ for the output of triangular wave signal. In most of motor control systems, the PWM frequency is at 10kHz to 20kHz, and one cycle time is 100μs for a 10kHz of PWM frequency. In current shunt monitoring for a motor phase, the phase current is converted to a phase voltage signal for ADC sampling. This sampling voltage signal must be settled before entering the ADC. As the Figure 8 shown, the total settling time of a current shunt monitor circuit includes: the rising edge delay time (t_{SR}) due to the op-amp's slew rate, and the measurement settling time (t_{SET}). For a 3-shunt solution in motor phase current sensing, if the smaller duty cycle of the PWM is defined at 45% (In fact, the phase with minimum PWM duty cycle, such as 5%, is not detected current directly, and it can be calculated from the other two phase currents), and the t_{SR} is required at 20% of a total time window for a phase current monitoring, in case of a 3.3V motor control system (3.3V MCU with 12-bit ADC), the op-amp's slew rate should be more than:

$$3.3V / (100\mu s \times 45\% \times 20\%) = 0.37 V/\mu s$$

At the same time, the op-amp's bandwidth should be much greater than the PWM frequency, like 10 time at least.

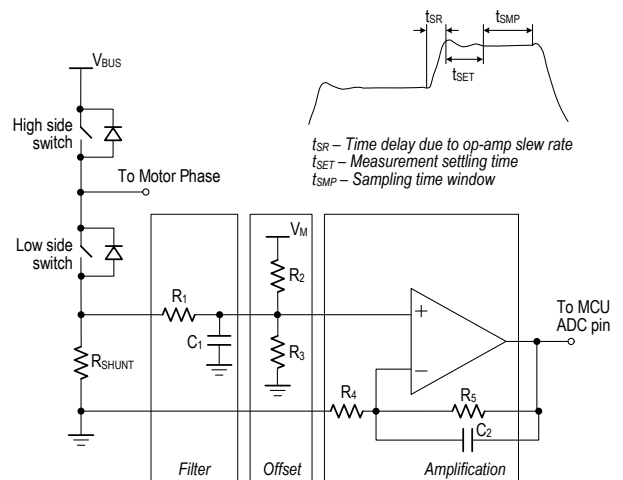
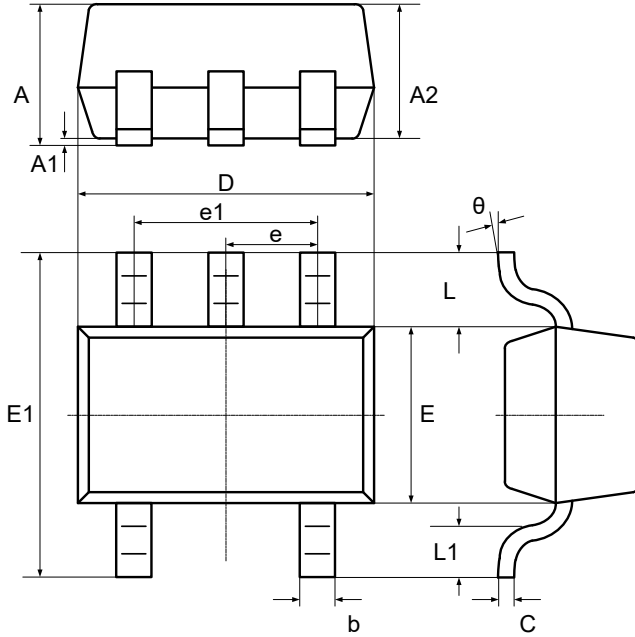

Figure 8. Current Shunt Monitor Circuit



Package Outlines

SC-70-5L (SOT-353)



Symbol	Dimensions In Millimeters		Dimensions In Inches	
	Min	Max	Min	Max
A	0.90	1.10	0.035	0.043
A1	0.00	0.10	0.000	0.004
A2	0.90	1.00	0.035	0.039
b	0.15	0.35	0.006	0.014
C	0.08	0.15	0.003	0.006
D	2.00	2.20	0.079	0.087
E	1.15	1.35	0.045	0.053
E1	2.15	2.45	0.085	0.096
e	0.65 TYP.		0.026 TYP.	
e1	1.20	1.40	0.047	0.055
L	0.525 REF.		0.021 REF.	
L1	0.26	0.46	0.010	0.018
θ	0°	8°	0°	8°

SOT-23-5L

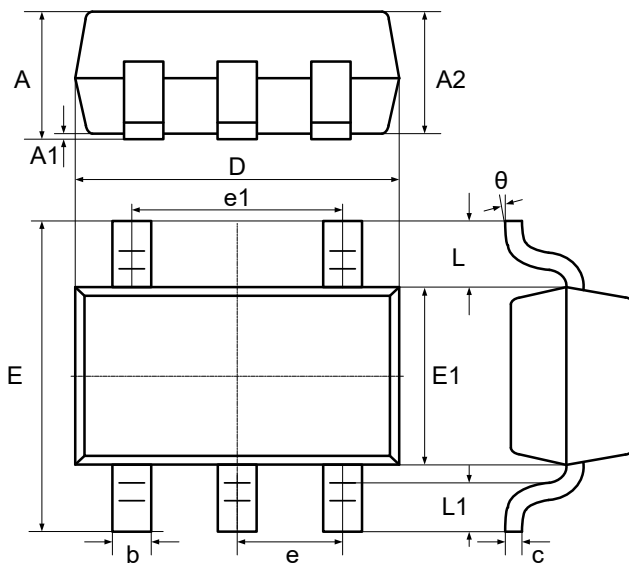

Symbol	Dimensions In Millimeters		Dimensions In Inches	
	Min	Max	Min	Max
A	-	1.25	-	0.049
A1	0.04	0.10	0.002	0.004
A2	1.00	1.20	0.039	0.047
b	0.33	0.41	0.013	0.016
c	0.15	0.19	0.006	0.007
D	2.820	3.02	0.111	0.119
E1	1.50	1.70	0.059	0.067
E	2.60	3.00	0.102	0.118
e	0.95 BSC.		0.037 BSC.	
e1	1.90 BSC.		0.075 BSC.	
L	0.60 REF.		0.024 REF.	
L1	0.30	0.60	0.012	0.024
θ	0°	8°	0°	8°



MSOP-8

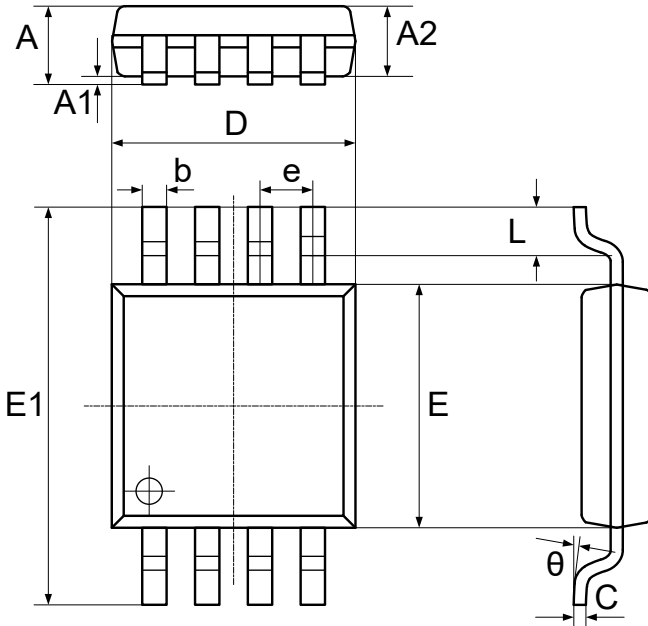

Symbol	Dimensions In Millimeters		Dimensions In Inches	
	Min	Max	Min	Max
A	0.800	1.100	0.033	0.045
A1	0.050	0.150	0.002	0.006
A2	0.750	0.950	0.031	0.039
b	0.290	0.380	0.012	0.016
C	0.150	0.200	0.006	0.008
D	2.900	3.100	0.118	0.127
E	2.900	3.100	0.118	0.127
E1	4.700	5.100	0.192	0.208
e	0.650 TYP.		0.026 TYP.	
L	0.400	0.700	0.016	0.029
θ	0° 8°		0° 8°	

SOP-8

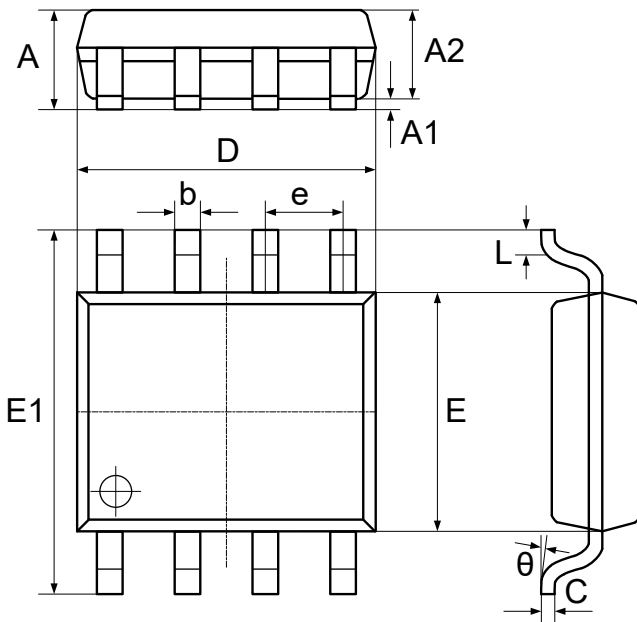

Symbol	Dimensions In Millimeters		Dimensions In Inches	
	Min	Max	Min	Max
A	1.370	1.670	0.056	0.068
A1	0.070	0.170	0.003	0.007
A2	1.300	1.500	0.053	0.061
b	0.306	0.506	0.013	0.021
C	0.203 TYP.		0.008 TYP.	
D	4.700	5.100	0.192	0.208
E	3.820	4.020	0.156	0.164
E1	5.800	6.200	0.237	0.253
e	1.270 TYP.		0.050 TYP.	
L	0.450	0.750	0.018	0.306
θ	0° 8°		0° 8°	



SOP-14

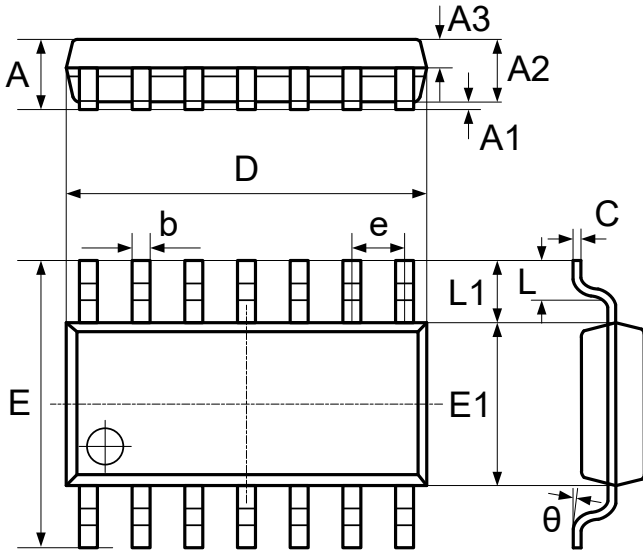

Symbol	Dimensions In Millimeters		Dimensions In Inches	
	Min	Max	Min	Max
A	1.450	1.850	0.059	0.076
A1	0.100	0.300	0.004	0.012
A2	1.350	1.550	0.055	0.063
A3	0.550	0.750	0.022	0.031
b	0.406 TYP.		0.017 TYP.	
C	0.203 TYP.		0.008 TYP.	
D	8.630	8.830	0.352	0.360
E	5.840	6.240	0.238	0.255
E1	3.850	4.050	0.157	0.165
e	1.270 TYP.		0.050 TYP.	
L1	1.040 REF.		0.041 REF.	
L	0.350	0.750	0.014	0.031
θ	2°	8°	2°	8°



Attention

- Any and all HUA XUANYANG ELECTRONICS products described or contained herein do not have specifications that can handle applications that require extremely high levels of reliability, such as life-support systems, aircraft's control systems, or other applications whose failure can be reasonably expected to result in serious physical and/or material damage. Consult with your HUA XUANYANG ELECTRONICS representative nearest you before using any HUA XUANYANG ELECTRONICS products described or contained herein in such applications.

- HUA XUANYANG ELECTRONICS assumes no responsibility for equipment failures that result from using products at values that exceed, even momentarily, rated values (such as maximum ratings, operating condition ranges, or other parameters) listed in products specifications of any and all HUA XUANYANG ELECTRONICS products described or contained herein.

- Specifications of any and all HUA XUANYANG ELECTRONICS products described or contained herein stipulate the performance, characteristics, and functions of the described products in the independent state, and are not guarantees of the performance, characteristics, and functions of the described products as mounted in the customer's products or equipment. To verify symptoms and states that cannot be evaluated in an independent device, the customer should always evaluate and test devices mounted in the customer's products or equipment.

- HUA XUANYANG ELECTRONICS CO.,LTD. strives to supply high-quality high-reliability products. However, any and all semiconductor products fail with some probability. It is possible that these probabilistic failures could give rise to accidents or events that could endanger human lives, that could give rise to smoke or fire, or that could cause damage to other property. When designing equipment, adopt safety measures so that these kinds of accidents or events cannot occur. Such measures include but are not limited to protective circuits and error prevention circuits for safe design, redundant design, and structural design.

- In the event that any or all HUA XUANYANG ELECTRONICS products(including technical data, services) described or contained herein are controlled under any of applicable local export control laws and regulations, such products must not be exported without obtaining the export license from the authorities concerned in accordance with the above law.

- No part of this publication may be reproduced or transmitted in any form or by any means, electronic or mechanical, including photocopying and recording, or any information storage or retrieval system, or otherwise, without the prior written permission of HUA XUANYANG ELECTRONICS CO.,LTD.

- Information (including circuit diagrams and circuit parameters) herein is for example only ; it is not guaranteed for volume production. HUA XUANYANG ELECTRONICS believes information herein is accurate and reliable, but no guarantees are made or implied regarding its use or any infringements of intellectual property rights or other rights of third parties.

- Any and all information described or contained herein are subject to change without notice due to product/technology improvement, etc. When designing equipment, refer to the "Delivery Specification" for the HUA XUANYANG ELECTRONICS product that you intend to use.