



## Product Description

The HOPAx338 family of single-, dual-, and quad- channel operational amplifiers represents a new generation of general-purpose, low-power op-amps. Featuring rail-to-rail input and output (RRIO) swings, low quiescent current (typical 750  $\mu$ A) combined with a wide bandwidth (11 MHz) and very low noise (8 nV/ $\sqrt{\text{Hz}}$  at 10 kHz) makes this family very attractive for a variety of battery-powered applications that require a good balance between cost and performance, such as audio outputs, motor phase current sensing, photodiode amplification, barcode scanners and white goods. The low input bias current supports these amplifiers to be used in applications with mega-ohm source impedances.

The robust design of the HOPAx338 amplifiers provides ease-of-use to the circuit designer: unity-gain stability with capacitive loads of up to 300 pF, integrated RF/EMI rejection filter, no phase reversal in overdrive conditions, and high electro-static discharge (ESD) protection (5-kV HBM). The HOPAx338 amplifiers are optimized for operation at voltages as low as +1.8 V ( $\pm 0.9$  V) and up to +5.5 V ( $\pm 2.75$  V) at the temperature range of 0°C to 70°C, and operation at voltages from +2.0 V ( $\pm 1.0$  V) to +5.5 V ( $\pm 2.75$  V) over the extended temperature range of -40°C to +125°C. The HOPA338 (single) is available in both SOT-23-5L packages. The HOPA2338 (dual) is offered in SOIC-8 packages.

## Features

- Low Input Offset Voltage:  $\pm 0.35$  mV Maximum
- Wide Unity-Gain Bandwidth: 11 MHz
- High Slew Rate: 11 V/ $\mu$ s
- Fast Settling: 0.26  $\mu$ s to 0.1%
- Low Noise: 8 nV/ $\sqrt{\text{Hz}}$  at 10 kHz
- Rail-to-Rail Input and Output
- Internal RF/EMI Filter
- Single 1.8 V to 5.5 V Supply Voltage Range at 0°C to 70°C
- Low Supply Current: 750  $\mu$ A at 5V Supply Per Amplifier
- Extended Temperature Range: -40°C to +125°C

## Applications

- Battery-Powered Instruments:
  - Consumer, Industrial, Medical, Notebooks
- Audio Outputs
- Motor Phase Current Sense
- Photodiode Amplification
- Sensor Signal Conditioning:
  - Sensor Interfaces, Loop-Powered, Active Filters

## Pin Configurations (Top View)

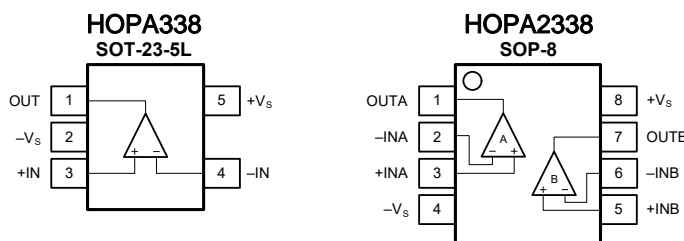



## Pin Description

Symbol	Description
-IN	Inverting input of the amplifier. The voltage range is from ( $V_S-0.1V$ ) to ( $V_{S+}+0.1V$ ).
+IN	Non-inverting input of the amplifier. This pin has the same voltage range as -IN.
+Vs	Positive power supply.
-Vs	Negative power supply.
OUT	Amplifier output.

## Limiting Value

In accordance with the Absolute Maximum Rating System (IEC 60134)

Parameter	Absolute Maximum Rating
Supply Voltage, $V_{S+}$ to $V_S$	10.0 V
Signal Input Terminals: Voltage, Current	$V_S - 0.5 V$ to $V_{S+} + 0.5 V$ , $\pm 10$ mA
Output Short-Circuit	Continuous
Storage Temperature Range, $T_{stg}$	$-65$ °C to $+150$ °C
Junction Temperature, $T_J$	150 °C
Lead Temperature Range (Soldering 10 sec)	260 °C

## ESD Rating

Parameter	Item	Value	Unit
Electrostatic Discharge Voltage	Human body model (HBM), per MIL-STD-883J / Method 3015.9 (1)	$\pm 5000$	V
	Charged device model (CDM), per ESDA/JEDEC JS-002-2014 (2)	$\pm 2000$	
	Machine model (MM), per JESD22-A115C	$\pm 250$	

(1) JEDEC document JEP155 states that 500-V HBM allows safe manufacturing with a standard ESD control process. Manufacturing with less than 500-V HBM is possible if necessary precautions are taken.

(2) JEDEC document JEP157 states that 250-V CDM allows safe manufacturing with a standard ESD control process. Manufacturing with less than 250-V CDM is possible if necessary precautions are taken.

## Ordering Information

Type Number	Package Name	Package Quantity
HOPA338NA	SOT-23-5L	Tape and Reel, 3000
HOPA2338UA	SOP-8	Tape and Reel, 3000



## Electrical Characteristics

$V_S = 5.0V$ ,  $T_A = +25^\circ C$ ,  $V_{CM} = V_S/2$ ,  $V_O = V_S/2$ , and  $R_L = 10k\Omega$  connected to  $V_S/2$ , unless otherwise noted.  
**Boldface limits apply over the specified temperature range,  $T_A = -40$  to  $+125^\circ C$ .**

Symbol	Parameter	Conditions	Min.	Typ.	Max.	Unit
<b>OFFSET VOLTAGE</b>						
$V_{OS}$	Input offset voltage			$\pm 0.10$	$\pm 0.35$	mV
$V_{OS}TC$	Offset voltage drift	$T_A = -40$ to $+125^\circ C$		$\pm 1$	2.3	$\mu V/^\circ C$
PSRR	Power supply rejection ratio	$V_S = 2.0$ to $5.5 V$ , $V_{CM} < V_{S+} - 2V$	95	110		dB
		$T_A = -40$ to $+125^\circ C$	82			
<b>INPUT BIAS CURRENT</b>						
$I_B$	Input bias current			1		pA
		$T_A = +85^\circ C$		150		
		$T_A = +125^\circ C$		500		
$I_{OS}$	Input offset current			1		pA
<b>NOISE</b>						
$V_n$	Input voltage noise	$f = 0.1$ to $10 Hz$		3		$\mu V_{P-P}$
$e_n$	Input voltage noise density	$f = 100 Hz$		19		$nV/\sqrt{Hz}$
		$f = 10 kHz$		8		
$I_n$	Input current noise density	$f = 1 kHz$		3		$fA/\sqrt{Hz}$
<b>INPUT VOLTAGE</b>						
$V_{CM}$	Common-mode voltage range		$V_{S-} - 0.1$		$V_{S+} + 0.1$	V
CMRR	Common-mode rejection ratio	$V_S = 5.5 V$ , $V_{CM} = -0.1$ to $5.6 V$	80	96		dB
		$V_{CM} = 0$ to $5.3 V$ , $T_A = -40$ to $+125^\circ C$	75			
		$V_S = 2.0 V$ , $V_{CM} = -0.1$ to $2.1 V$	76	90		
		$V_{CM} = 0$ to $1.8 V$ , $T_A = -40$ to $+125^\circ C$	70			
<b>INPUT IMPEDANCE</b>						
$C_{IN}$	Input capacitance	Differential		2.0		pF
		Common mode		3.5		
<b>OPEN-LOOP GAIN</b>						
$A_{VOL}$	Open-loop voltage gain	$R_L = 10 k\Omega$ , $V_O = 0.05$ to $3.5 V$	97	105		dB
		$T_A = -40$ to $+125^\circ C$	87			
		$R_L = 600 \Omega$ , $V_O = 0.15$ to $3.5 V$	85	90		
		$T_A = -40$ to $+125^\circ C$	75			
<b>FREQUENCY RESPONSE</b>						
GBW	Gain bandwidth product			11		MHz
SR	Slew rate	$G = +1$ , $C_L = 100 pF$ , $V_O = 1.5$ to $3.5 V$		11		$V/\mu s$
THD+N	Total harmonic distortion +noise	$G = +1$ , $f = 1 kHz$ , $V_O = 0.5 V_{RMS}$		0.0005		%
$t_s$	Settling time	To 0.1%, $G = +1$ , 1V step		0.26		$\mu s$
		To 0.01%, $G = +1$ , 1V step		0.34		
$t_{OR}$	Overload recovery time	$V_{IN} * Gain > V_S$		0.3		$\mu s$



Symbol	Parameter	Conditions	Min.	Typ.	Max.	Unit
<i>OUTPUT</i>						
V <sub>OH</sub>	High output voltage swing	R <sub>L</sub> = 10 kΩ	V <sub>S+</sub> -12	V <sub>S+</sub> -8		mV
		R <sub>L</sub> = 600 Ω	V <sub>S+</sub> -180	V <sub>S+</sub> -125		
V <sub>OL</sub>	Low output voltage swing	R <sub>L</sub> = 10 kΩ		V <sub>S-</sub> +6	V <sub>S-</sub> +9	mV
		R <sub>L</sub> = 600 Ω		V <sub>S-</sub> +90	V <sub>S-</sub> +130	
I <sub>sc</sub>	Short-circuit current			±75		mA
<i>POWER SUPPLY</i>						
V <sub>s</sub>	Operating supply voltage	T <sub>A</sub> = 0 to +70 °C	1.8		5.5	V
		T <sub>A</sub> = -40 to +125 °C	2.0		5.5	
I <sub>q</sub>	Quiescent current (per amplifier)	V <sub>S</sub> = 2.0 V		625	760	μA
		V <sub>S</sub> = 5.0 V		750	930	
<i>THERMAL CHARACTERISTICS</i>						
T <sub>A</sub>	Operating temperature range		-40		+125	°C
θ <sub>JA</sub>	Package Thermal Resistance	SOT-23-5L		190		°C/W
		SOP-8		125		



## Typical Performance Characteristics

At  $T_A = +25^\circ\text{C}$ ,  $V_{CM} = V_S/2$ , and  $R_L = 10\text{k}\Omega$  connected to  $V_S/2$ , unless otherwise noted.

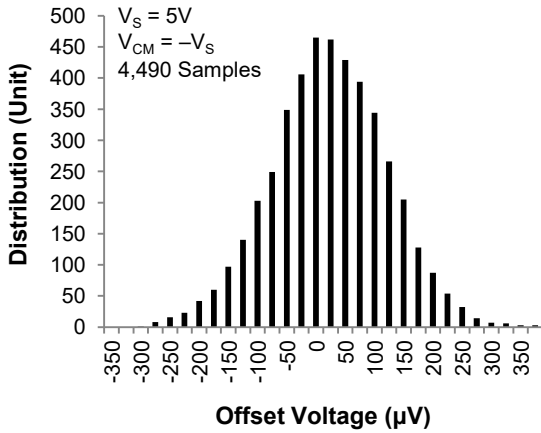

Offset Voltage Production Distribution

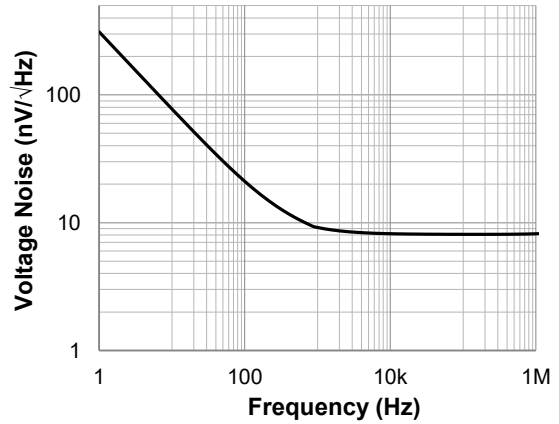

Input Voltage Noise Spectral Density as a function of Frequency.

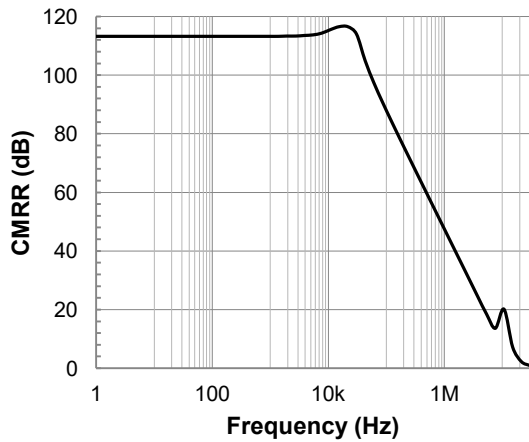

Common-mode Rejection Ratio as a function of Frequency.

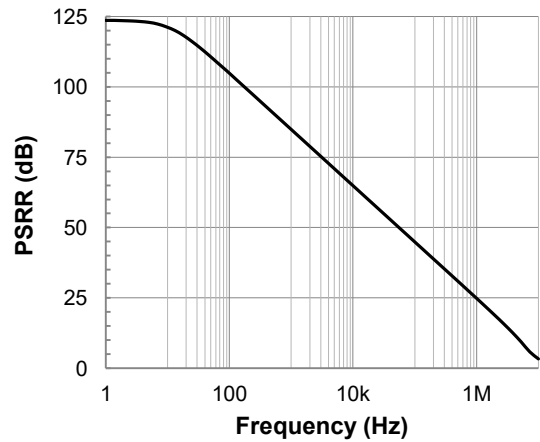

Power Supply Rejection Ratio as a function of Frequency.

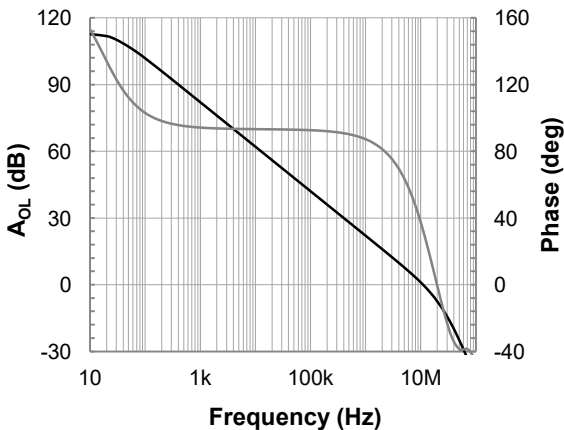

Open-loop Gain and Phase as a function of Frequency.

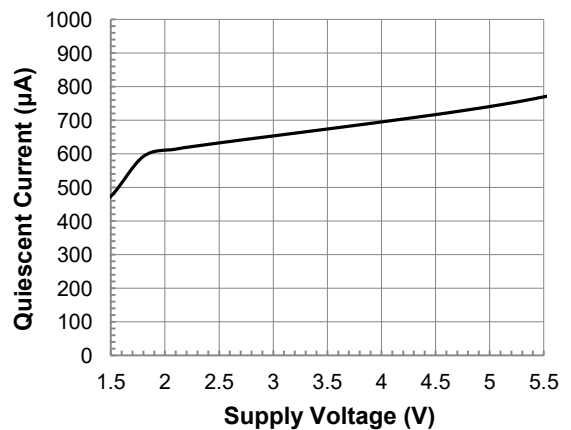

Quiescent Current as a function of Supply Voltage.

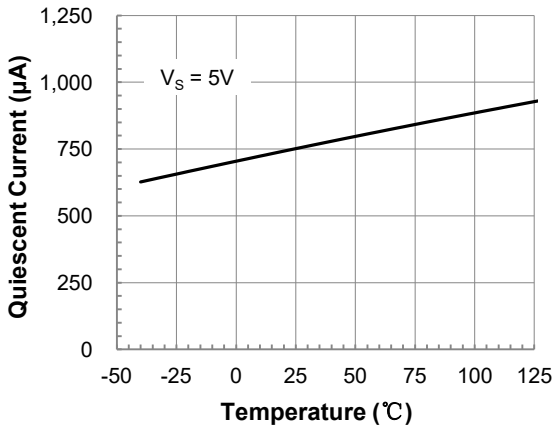

Quiescent Current as a function of Temperature.

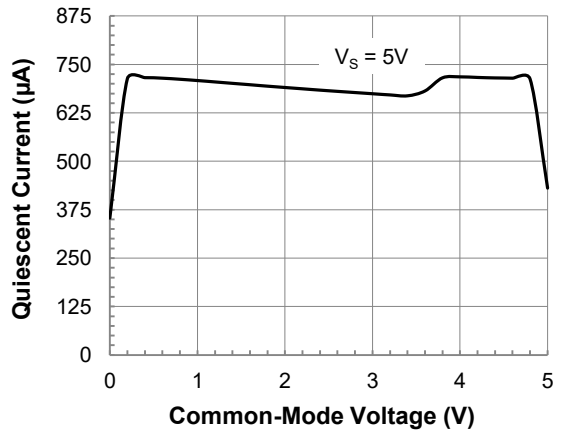

Quiescent Current as a function of Input Common-mode Voltage.

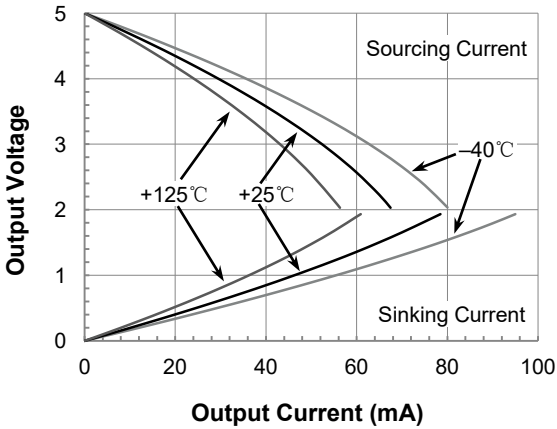

Output Voltage Swing as a function of Output Current.

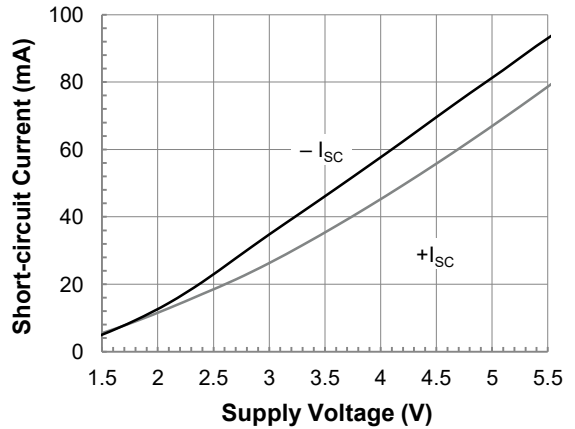

Short-circuit Current as a function of Supply Voltage.

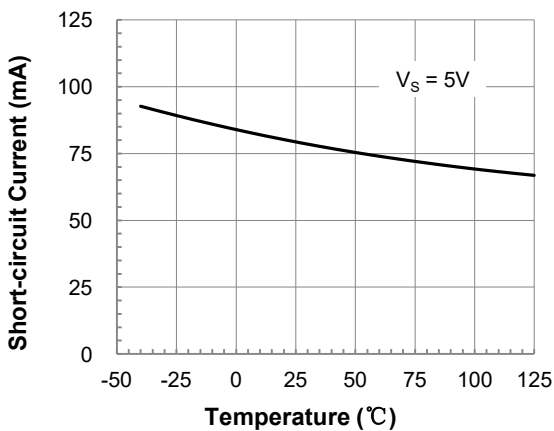

Short-circuit Current as a function of Temperature.

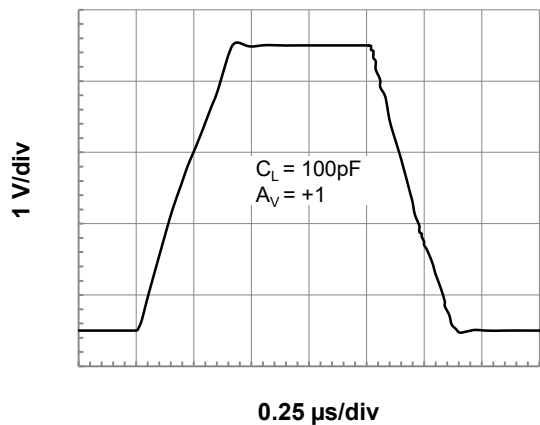

Large Signal Step Response.

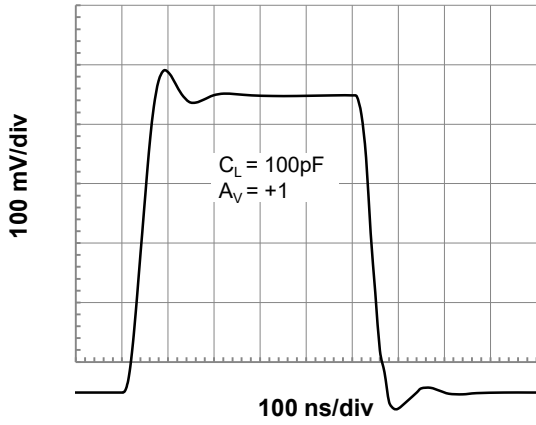

Small Signal Step Response (500 mV).

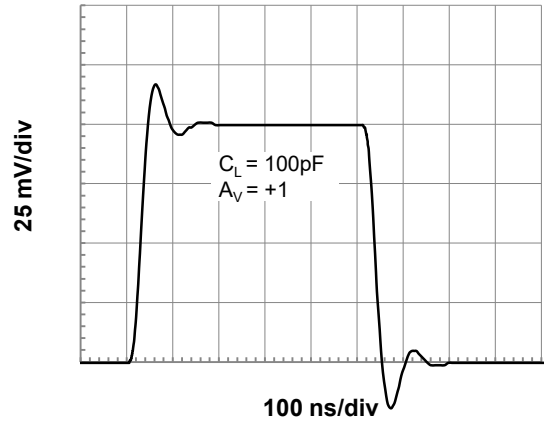

Small Signal Step Response (500 mV).



## Application Notes

The HOPAx338 is a family of low-power, rail-to-rail input and output operational amplifiers specifically designed for portable applications. These devices operate from 1.8 V to 5.5 V at the temperature range of 0 °C to 70 °C, are unity-gain stable, and suitable for a wide range of general-purpose applications. The class AB output stage is capable of driving  $\leq 10\text{-k}\Omega$  loads connected to any point between  $V_{S+}$  and ground.

The input common-mode voltage range includes both rails, and allows the HOPAx338 family to be used in virtually any single-supply application. Rail-to-rail input and output swing significantly increases dynamic range, especially in low-supply applications, and makes them ideal for driving sampling analog-to-digital converters (ADCs). The HOPAx338 features 11-MHz bandwidth and 11-V/ $\mu\text{s}$  slew rate with only 750- $\mu\text{A}$  supply current per amplifier, providing good ac performance at very low power consumption. DC applications are also well served with a low input noise voltage of 8-nV/ $\sqrt{\text{Hz}}$  at 1-kHz, low input bias current, and an input offset voltage of 0.35-mV maximum. The typical offset voltage drift is 1- $\mu\text{V}/^\circ\text{C}$ , over the full temperature range the input offset voltage changes only 100- $\mu\text{V}$  (0.35-mV to 0.45-mV).

### OPERATING VOLTAGE

The HOPAx338 family is optimized for operation at voltages as low as +1.8 V ( $\pm 0.9$  V) and up to +5.5 V ( $\pm 2.75$  V) at the temperature range of 0 °C to 70 °C, and fully specified and ensured for operation from 2.0V to 5.5 V ( $\pm 1.0$  V to  $\pm 2.75$  V). In addition, many specifications apply from  $-40^\circ\text{C}$  to  $+125^\circ\text{C}$ . Parameters that vary significantly with operating voltages or temperature are illustrated in the Typical Characteristics graphs.

### RAIL-TO-RAIL INPUT

The input common-mode voltage range of the HOPAx338 series extends 100-mV beyond the negative and positive supply rails. This performance is achieved with a complementary input stage: an N-channel input differential pair in parallel with a P-channel differential pair. The N-channel pair is active for input voltages close to the positive rail, typically  $V_{S+} - 1.4\text{V}$  to the positive supply, whereas the P-channel pair is active for inputs from 100-mV below the negative supply to approximately  $V_{S+} - 1.4$  V. There is a small transition region, typically  $V_{S+} - 1.2$  V to  $V_{S+} - 1$  V, in which both pairs are on. This 200-mV transition region can vary up to 200-mV with process variation. Thus, the transition region (both stages on) can range from  $V_{S+} - 1.4$  V to  $V_{S+} - 1.2$  V on the low end, up to  $V_{S+} - 1$  V to  $V_{S+} - 0.8$  V on the high end. Within this transition region, PSRR, CMRR, offset

voltage, offset drift, and THD can be degraded compared to device operation outside this region.

The typical input bias current of the HOPAx338 during normal operation is approximately 1-pA. In overdriven conditions, the bias current can increase significantly.

The most common cause of an overdriven condition occurs when the operational amplifier is outside of the linear range of operation. When the output of the operational amplifier is driven to one of the supply rails, the feedback loop requirements cannot be satisfied and a differential input voltage develops across the input pins. This differential input voltage results in activation of parasitic diodes inside the front-end input chopping switches that combine with electromagnetic interference (EMI) filter resistors to create the equivalent circuit. Notice that the input bias current remains within specification in the linear region.

### INPUT EMI FILTER AND CLAMP CIRCUIT

Figure 1 shows the input EMI filter and clamp circuit. The HOPAx338 op-amps have internal ESD protection diodes (D1, D2, D3, and D4) that are connected between the inputs and each supply rail. These diodes protect the input transistors in the event of electrostatic discharge and are reverse biased during normal operation. This protection scheme allows voltages as high as approximately 500-mV beyond the rails to be applied at the input of either terminal without causing permanent damage. These ESD protection current-steering diodes also provide in-circuit, input overdrive protection, as long as the current is limited to 20-mA as stated in the Absolute Maximum Ratings.

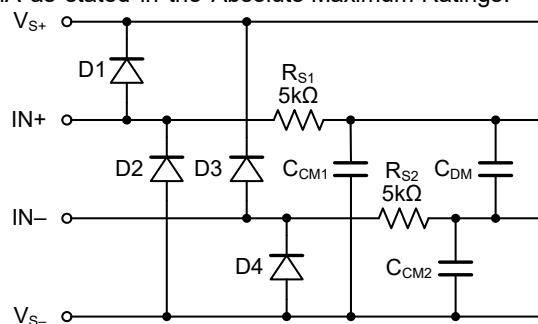

Figure 1. Input EMI Filter and Clamp Circuit

Operational amplifiers vary in susceptibility to EMI. If conducted EMI enters the operational amplifier, the dc offset at the amplifier output can shift from its nominal value when EMI is present. This shift is a result of signal rectification associated with the internal semiconductor junctions. Although all operational amplifier pin functions can be affected by EMI, the input pins are likely to be the most susceptible. The EMI filter of the HOPAx338 family is





composed of two 5-k $\Omega$  input series resistors ( $R_{S1}$  and  $R_{S2}$ ), two common-mode capacitors ( $C_{CM1}$  and  $C_{CM2}$ ), and a differential capacitor ( $C_{DM}$ ). These RC networks set the -3 dB low-pass cutoff frequencies at 35-MHz for common-mode signals, and at 22-MHz for differential signals.

### RAIL-TO-RAIL OUTPUT

Designed as a micro-power, low-noise operational amplifier, the HOPAx338 delivers a robust output drive capability. A class AB output stage with common-source transistors is used to achieve full rail-to-rail output swing capability. For resistive loads up to 100-k $\Omega$ , the output swings typically to within 5-mV of either supply rail regardless of the power-supply voltage applied. Different load conditions change the ability of the amplifier to swing close to the rails. For resistive loads up to 600- $\Omega$ , the output swings typically to within 125-mV of the positive supply rail and within 90-mV of the negative supply rail.

### CAPACITIVE LOAD AND STABILITY

The HOPAx338 family can safely drive capacitive loads of up to 300-pF in any configuration. As with most amplifiers, driving larger capacitive loads than specified may cause excessive overshoot and ringing, or even oscillation. A heavy capacitive load reduces the phase margin and causes the amplifier frequency response to peak. Peaking corresponds to over-shooting or ringing in the time domain. Therefore, it is recommended that external compensation be used if the HOPAx338 op-amps must drive a load exceeding 300-pF. This compensation is particularly important in the unity-gain configuration, which is the worst case for stability.

A quick and easy way to stabilize the op-amp for capacitive load drive is by adding a series resistor,  $R_{ISO}$ , between the amplifier output terminal and the load capacitance, as shown in Figure 2.  $R_{ISO}$  isolates the amplifier output and feedback network from the capacitive load. The bigger the  $R_{ISO}$  resistor value, the more stable  $V_{OUT}$  will be. Note that this method results in a loss of gain accuracy because  $R_{ISO}$  forms a voltage divider with the  $R_L$ .

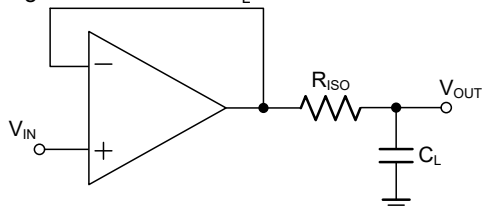

Figure 2. Indirectly Driving Heavy Capacitive Load

An improvement circuit is shown in Figure 3. It provides DC accuracy as well as AC stability. The  $R_F$  provides the DC accuracy by connecting the inverting

signal with the output.

The  $C_F$  and  $R_{ISO}$  serve to counteract the loss of phase margin by feeding the high frequency component of the output signal back to the amplifier's inverting input, thereby preserving phase margin in the overall feedback loop.

For no-buffer configuration, there are two others ways to increase the phase margin: (a) by increasing the amplifier's gain, or (b) by placing a capacitor in parallel with the feedback resistor to counteract the parasitic capacitance associated with inverting node.

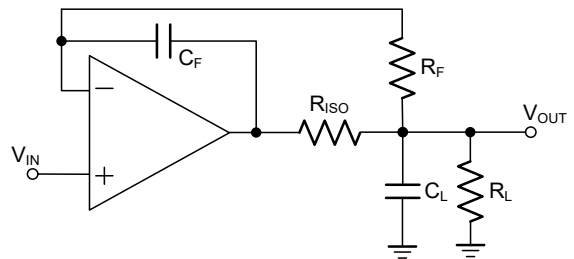

Figure 3. Indirectly Driving Heavy Capacitive Load with DC Accuracy

### OVERLOAD RECOVERY

Overload recovery is defined as the time required for the operational amplifier output to recover from a saturated state to a linear state. The output devices of the operational amplifier enter a saturation region when the output voltage exceeds the rated operating voltage, either because of the high input voltage or the high gain. After the device enters the saturation region, the charge carriers in the output devices require time to return back to the linear state. After the charge carriers return back to the linear state, the device begins to slew at the specified slew rate. Thus, the propagation delay in case of an overload condition is the sum of the overload recovery time and the slew time. The overload recovery time for the HOPAx338 family is approximately 0.3- $\mu$ s.

### EMI REJECTION RATIO

Circuit performance is often adversely affected by high frequency EMI. When the signal strength is low and transmission lines are long, an op-amp must accurately amplify the input signals. However, all op-amp pins — the non-inverting input, inverting input, positive supply, negative supply, and output pins — are susceptible to EMI signals. These high frequency signals are coupled into an op-amp by various means, such as conduction, near field radiation, or far field radiation. For example, wires and printed circuit board (PCB) traces can act as antennas and pick up high frequency EMI signals.



Amplifiers do not amplify EMI or RF signals due to their relatively low bandwidth. However, due to the nonlinearities of the input devices, op-amps can rectify these out of band signals. When these high frequency signals are rectified, they appear as a dc offset at the output.

The HOPAx338 op-amps have integrated EMI filters at their input stage. A mathematical method of measuring EMIRR is defined as follows:

$$EMIRR = 20 \log (V_{IN\_PEAK} / \Delta V_{OS})$$

#### **INPUT-TO-OUTPUT COUPLING**

To minimize capacitive coupling, the input and output signal traces should not be parallel. This helps reduce unwanted positive feedback.

#### **MAXIMIZING PERFORMANCE THROUGH PROPER LAYOUT**

To achieve the maximum performance of the extremely high input impedance and low offset voltage of the HOPAx338 op-amps, care is needed in laying out the circuit board. The PCB surface must remain clean and free of moisture to avoid leakage currents between adjacent traces. Surface coating of the circuit board reduces surface moisture and provides a humidity barrier, reducing parasitic resistance on the board. The use of guard rings around the amplifier inputs further reduces leakage currents. Figure 4 shows proper guard ring configuration and the top view of a surface-mount layout. The guard ring does not need to be a specific width, but it should form a continuous loop around both inputs. By setting the guard ring voltage equal to the voltage at the non-inverting input, parasitic capacitance is minimized as well. For further reduction of leakage currents, components can be mounted to the PCB using Teflon standoff insulators.

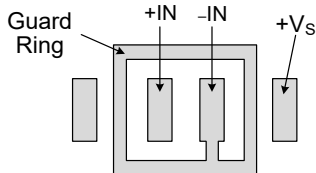

Figure 4. Use a guard ring around sensitive pins

Other potential sources of offset error are thermoelectric voltages on the circuit board. This voltage, also called Seebeck voltage, occurs at the junction of two dissimilar metals and is proportional to the temperature of the junction. The most common metallic junctions on a circuit board are solder-to-board trace and solder-to-component lead. If the temperature of the PCB at one end of the component is different from the temperature at the other end, the resulting Seebeck voltages are not equal, resulting in

a thermal voltage error.

This thermocouple error can be reduced by using dummy components to match the thermoelectric error source. Placing the dummy component as close as possible to its partner ensures both Seebeck voltages are equal, thus canceling the thermocouple error. Maintaining a constant ambient temperature on the circuit board further reduces this error. The use of a ground plane helps distribute heat throughout the board and reduces EMI noise pickup.



## Typical Application Circuits

### ACTIVE FILTER

The HOPAx338 family is well-suited for active filter applications that require a wide bandwidth, fast slew rate, low-noise, single-supply operational amplifier.

Figure 5 shows a 500-kHz, second-order, low-pass filter using the multiple-feedback (MFB) topology. The components have been selected to provide a maximally-flat Butterworth response. Beyond the cut-off frequency, roll-off is  $-40$  dB/dec. The Butterworth response is ideal for applications that require predictable gain characteristics, such as the anti-aliasing filter used in front of an ADC.

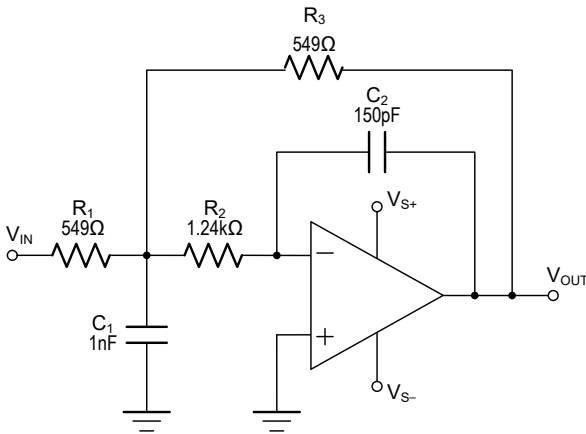

Figure 5. Second-Order, Butterworth, 500-kHz Low-Pass Filter

One point to observe when considering the MFB filter is that the output is inverted, relative to the input. If this inversion is not required, or not desired, a non-inverting output can be achieved through one of these options:

1. adding an inverting amplifier;
2. adding an additional second-order MFB stage; or
3. using a non-inverting filter topology, such as the Sallen-Key (shown in Figure 6).

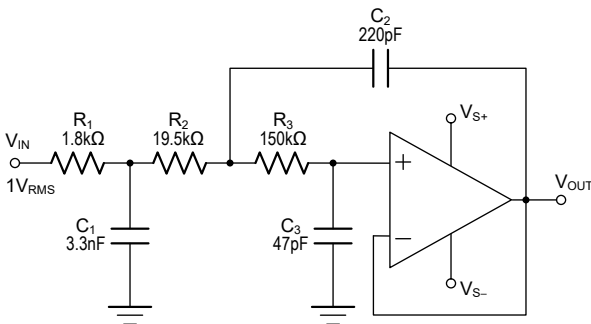

Figure 6. Configured as a Three-Pole, 20-kHz, Sallen-Key Filter

### MOTOR PHASE CURRENT SENSING

The current sensing amplification shown in Figure 7 has a slew rate of  $2\pi$  V<sub>PP</sub> for the output of sine wave signal, and has a slew rate of  $2$  V<sub>PP</sub> for the output of triangular wave signal. In most of motor control systems, the PWM frequency is at 10 kHz to 20 kHz, and one cycle time is  $100 \mu$ s for a 10 kHz of PWM frequency. In current shunt monitoring for a motor phase, the phase current is converted to a phase voltage signal for ADC sampling. This sampling voltage signal must be settled before entering the ADC. As the Figure 7 shown, the total settling time of a current shunt monitor circuit includes: the rising edge delay time ( $t_{SR}$ ) due to the op-amp's slew rate, and the measurement settling time ( $t_{SET}$ ). For a 2-shunt solution of motor phase current sensing, if the minimum duty cycle of the PWM is defined at 5%, and the  $t_{SR}$  is required at 20% of a total time window for a phase current monitoring, in case of a 3.3 V motor control system (3.3 V MCU with 12-bit ADC), the op-amp's slew rate should be more than:

$$3.3V / (100\mu s \times 5\% \times 20\%) = 3.3 V/\mu s$$

At the same time, the op-amp's bandwidth should be much greater than the PWM frequency, like 10 time at least.

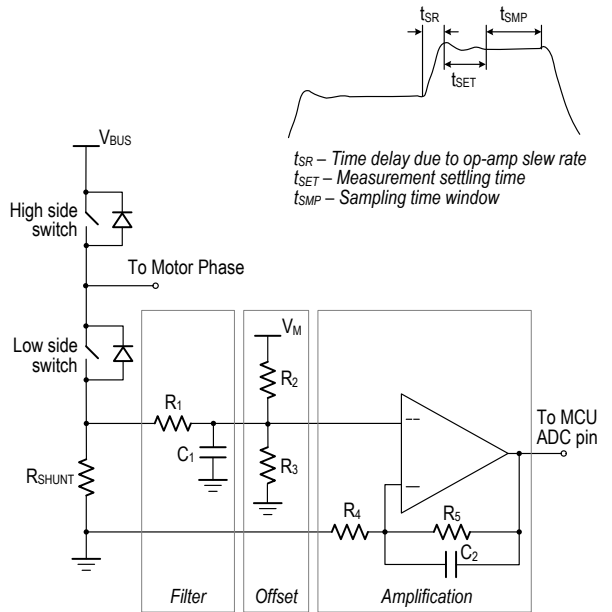

Figure 7. Current Shunt Monitor Circuit

### DIFFERENTIAL AMPLIFIER

The circuit shown in Figure 8 performs the difference function. If the resistors ratios are equal  $R_4/R_3 = R_2/R_1$ , then:

$$V_{OUT} = (V_p - V_n) \times R_2/R_1 + V_{REF}$$

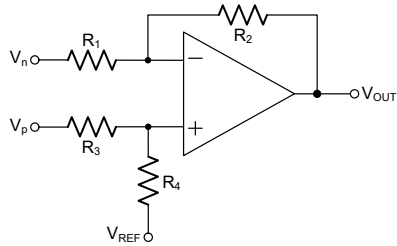

Figure 8. Differential Amplifier

### INSTRUMENTATION AMPLIFIER

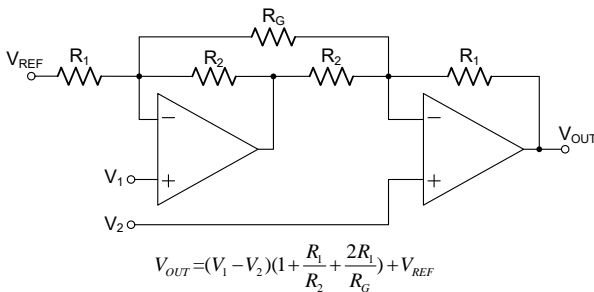
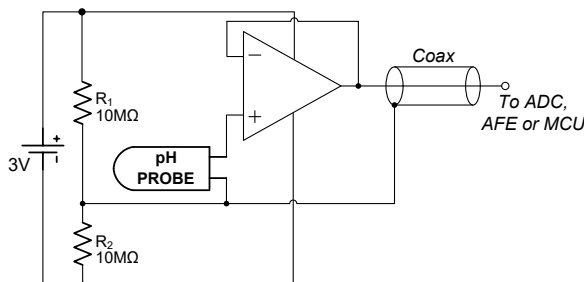

Figure 9. Instrumentation Amplifier

The HOPAx338 family is well suited for conditioning sensor signals in battery-powered applications.

Figure 9 shows a two op-amp instrumentation amplifier, using the HOPAx338 op-amps. The circuit works well for applications requiring rejection of common-mode noise at higher gains. The reference voltage ( $V_{REF}$ ) is supplied by a low-impedance source. In single voltage supply applications, the  $V_{REF}$  is typically  $V_S/2$ .

### BUFFERED CHEMICAL SENSORS



All components contained within the pH probe

Figure 10. Buffered pH Probe

The HOPAx338 family has input bias current in the pA range. This is ideal in buffering high impedance chemical sensors, such as pH probes. As an example, the circuit in Figure 10 eliminates expansive

low-leakage cables that that is required to connect a pH probe (general purpose combination pH probes, e.g Corning 476540) to metering ICs such as ADC, AFE and/or MCU. A HOPAx338 op-amp and a lithium battery are housed in the probe assembly. A conventional low-cost coaxial cable can be used to carry the op-amp's output signal to subsequent ICs for pH reading.



## Package Outlines

### DIMENSIONS, SOT-23-5L

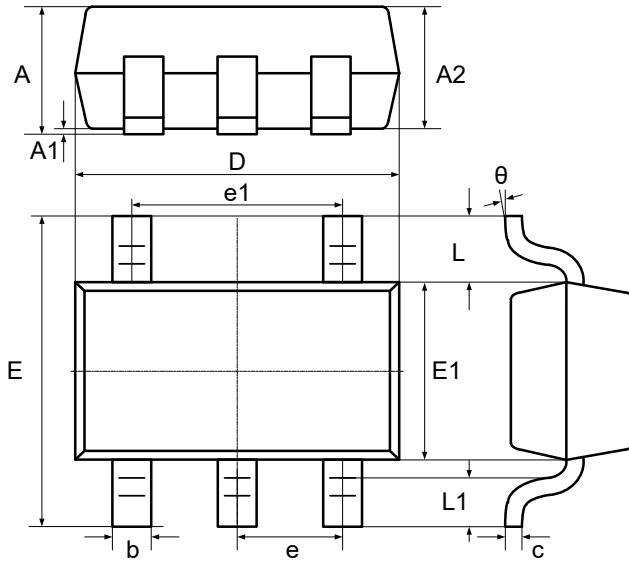

Symbol	Dimensions In Millimeters		Dimensions In Inches	
	Min	Max	Min	Max
A	-	1.25	-	0.049
A1	0.04	0.10	0.002	0.004
A2	1.00	1.20	0.039	0.047
b	0.33	0.41	0.013	0.016
c	0.15	0.19	0.006	0.007
D	2.820	3.02	0.111	0.119
E1	1.50	1.70	0.059	0.067
E	2.60	3.00	0.102	0.118
e	0.95 BSC		0.037 BSC	
e1	1.90 BSC		0.075 BSC	
L	0.60 REF		0.024 REF	
L1	0.30	0.60	0.012	0.024
$\theta$	0°	8°	0°	8°

### RECOMMENDED SOLDERING FOOTPRINT, SOT-23-5L

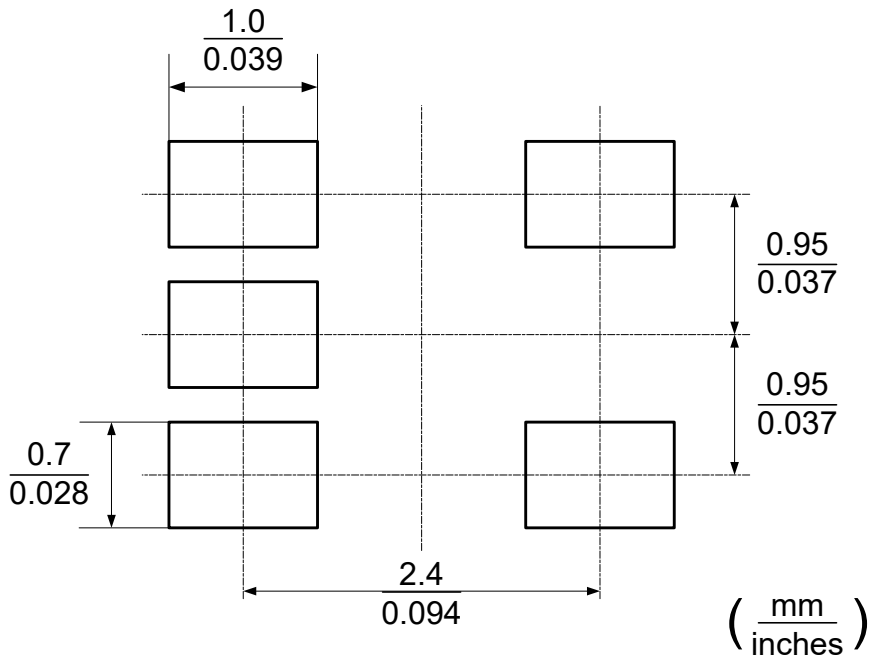



**DIMENSIONS, SOP-8**

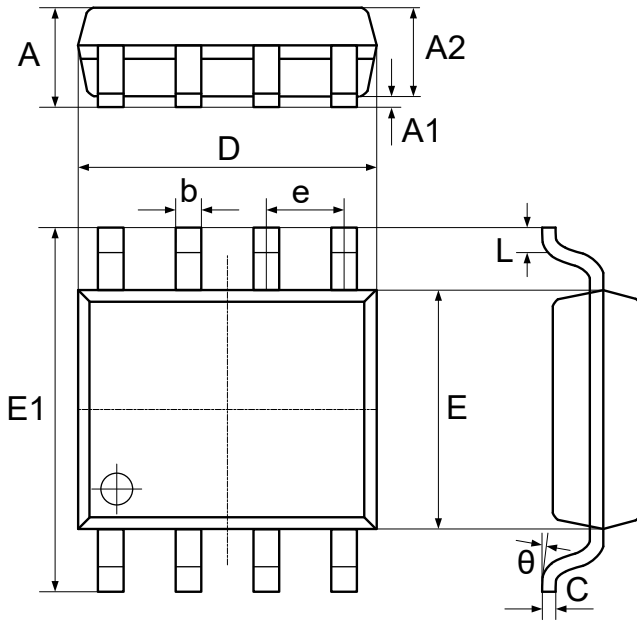

Symbol	Dimensions In Millimeters		Dimensions In Inches	
	Min	Max	Min	Max
A	1.370	1.670	0.054	0.066
A1	0.070	0.170	0.003	0.007
A2	1.300	1.500	0.051	0.059
b	0.306	0.506	0.012	0.020
C	0.203 TYP.		0.008 TYP.	
D	4.700	5.100	0.185	0.201
E	3.820	4.020	0.150	0.158
E1	5.800	6.200	0.228	0.244
e	1.270 TYP.		0.050 TYP.	
L	0.450	0.750	0.018	0.030
$\theta$	0°	8°	0°	8°

**RECOMMENDED SOLDERING FOOTPRINT, SOP-8**

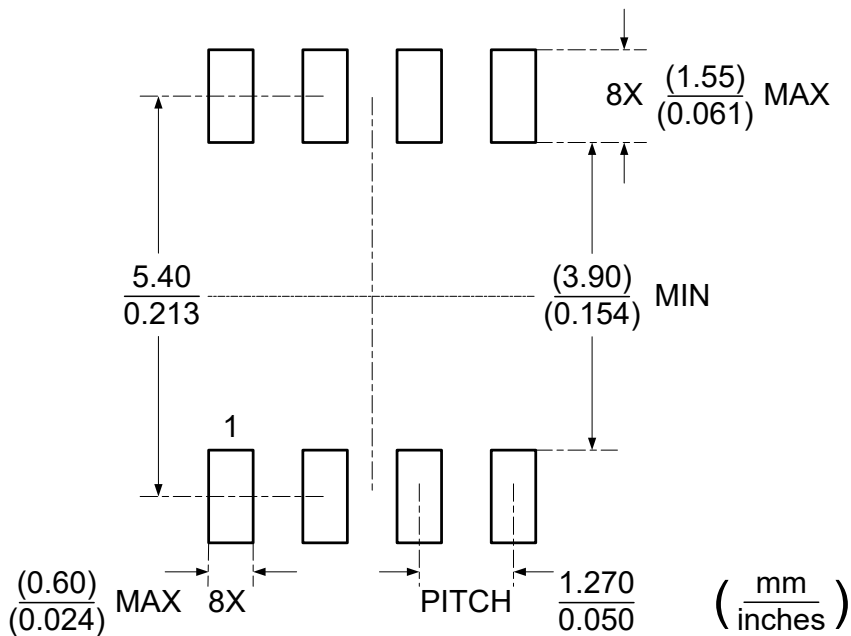



**DIMENSIONS, MSOP-8L**

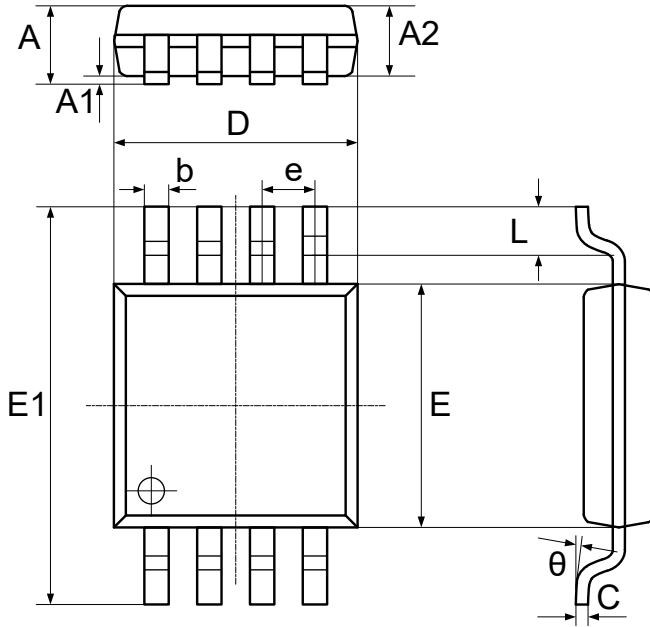

Symbol	Dimensions In Millimeters		Dimensions In Inches	
	Min	Max	Min	Max
A	0.800	1.100	0.031	0.043
A1	0.050	0.150	0.002	0.006
A2	0.750	0.950	0.030	0.037
b	0.290	0.380	0.011	0.015
C	0.150	0.200	0.006	0.008
D	2.900	3.100	0.114	0.122
E	2.900	3.100	0.114	0.122
E1	4.700	5.100	0.185	0.201
e	0.650 TYP.		0.026 TYP.	
L	0.400	0.700	0.016	0.028
$\theta$	0°	8°	0°	8°

**RECOMMENDED SOLDERING FOOTPRINT, MSOP-8L**

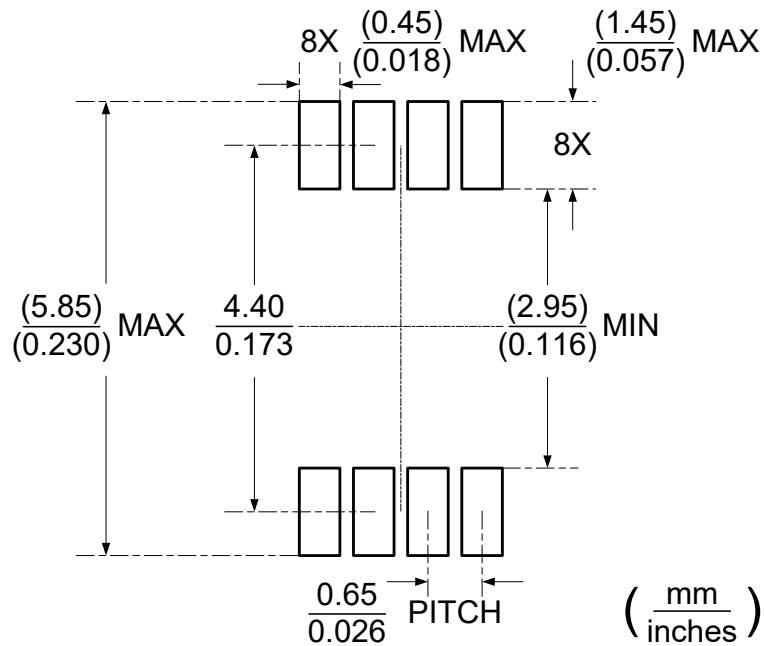



**DIMENSIONS, SOP-14**

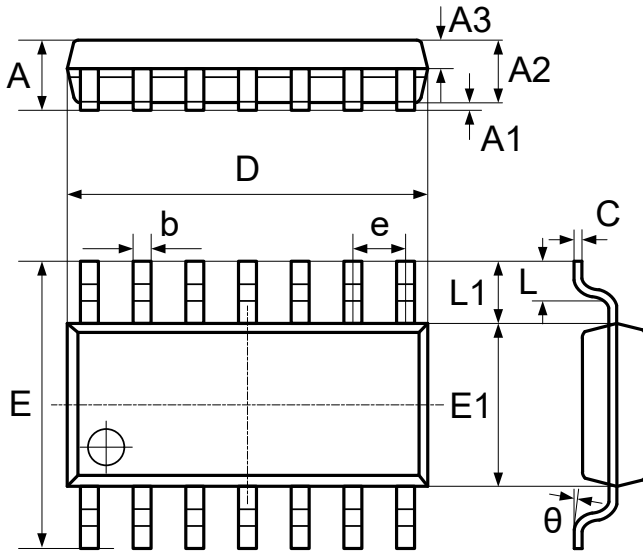

Symbol	Dimensions In Millimeters		Dimensions In Inches	
	Min	Max	Min	Max
A	1.450	1.850	0.057	0.073
A1	0.100	0.300	0.004	0.012
A2	1.350	1.550	0.053	0.061
A3	0.550	0.750	0.022	0.030
b	0.406 TYP.		0.016 TYP.	
C	0.203 TYP.		0.008 TYP.	
D	8.630	8.830	0.340	0.348
E	5.840	6.240	0.230	0.246
E1	3.850	4.050	0.152	0.159
e	1.270 TYP.		0.050 TYP.	
L1	1.040 REF.		0.041 REF.	
L	0.350	0.750	0.014	0.030
$\theta$	2°	8°	2°	8°

**RECOMMENDED SOLDERING FOOTPRINT, SOP-14**

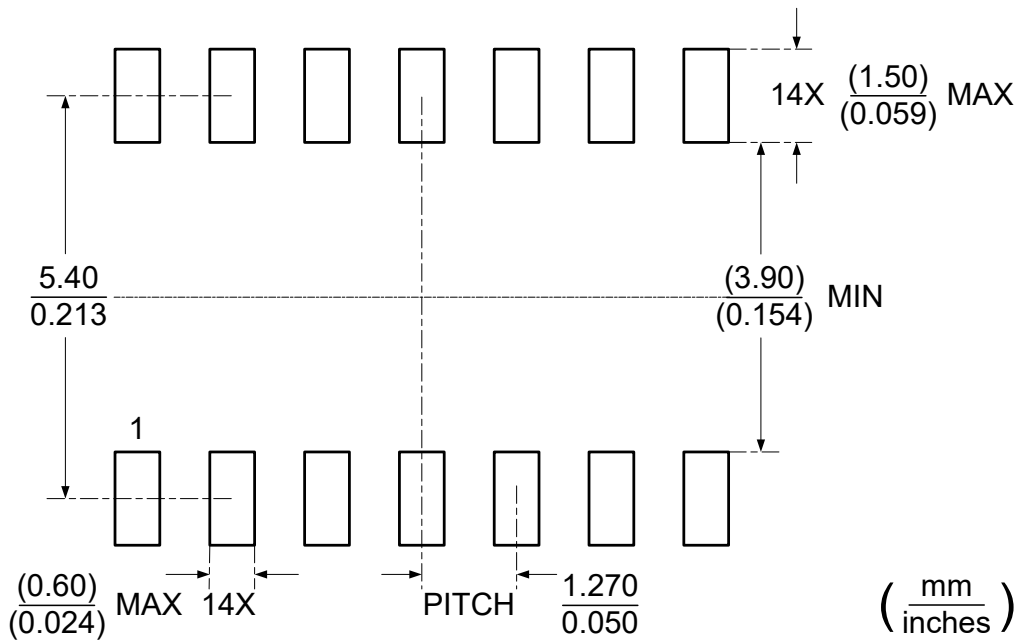





### **Attention**

- Any and all HUA XUANYANG ELECTRONICS products described or contained herein do not have specifications that can handle applications that require extremely high levels of reliability, such as life-support systems, aircraft's control systems, or other applications whose failure can be reasonably expected to result in serious physical and/or material damage. Consult with your HUA XUANYANG ELECTRONICS representative nearest you before using any HUA XUANYANG ELECTRONICS products described or contained herein in such applications.
  
- HUA XUANYANG ELECTRONICS assumes no responsibility for equipment failures that result from using products at values that exceed, even momentarily, rated values (such as maximum ratings, operating condition ranges, or other parameters) listed in products specifications of any and all HUA XUANYANG ELECTRONICS products described or contained herein.
  
- Specifications of any and all HUA XUANYANG ELECTRONICS products described or contained herein stipulate the performance, characteristics, and functions of the described products in the independent state, and are not guarantees of the performance, characteristics, and functions of the described products as mounted in the customer's products or equipment. To verify symptoms and states that cannot be evaluated in an independent device, the customer should always evaluate and test devices mounted in the customer's products or equipment.
  
- HUA XUANYANG ELECTRONICS CO.,LTD. strives to supply high-quality high-reliability products. However, any and all semiconductor products fail with some probability. It is possible that these probabilistic failures could give rise to accidents or events that could endanger human lives, that could give rise to smoke or fire, or that could cause damage to other property. When designing equipment, adopt safety measures so that these kinds of accidents or events cannot occur. Such measures include but are not limited to protective circuits and error prevention circuits for safe design, redundant design, and structural design.
  
- In the event that any or all HUA XUANYANG ELECTRONICS products(including technical data, services) described or contained herein are controlled under any of applicable local export control laws and regulations, such products must not be exported without obtaining the export license from the authorities concerned in accordance with the above law.
  
- No part of this publication may be reproduced or transmitted in any form or by any means, electronic or mechanical, including photocopying and recording, or any information storage or retrieval system, or otherwise, without the prior written permission of HUA XUANYANG ELECTRONICS CO.,LTD.
  
- Information (including circuit diagrams and circuit parameters) herein is for example only ; it is not guaranteed for volume production. HUA XUANYANG ELECTRONICS believes information herein is accurate and reliable, but no guarantees are made or implied regarding its use or any infringements of intellectual property rights or other rights of third parties.