

THIS IS A C.A.D. GENERATED DRAWING  
DO NOT MAKE MANUAL REVISIONS TO MASTER.

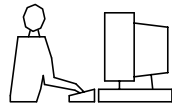

\* UNLESS OTHERWISE SPECIFIED TOLERANCES  
ON DECIMAL IS: ANGLE ±5°  
UNIT: MM X. ±0.38  
X.X ±0.25

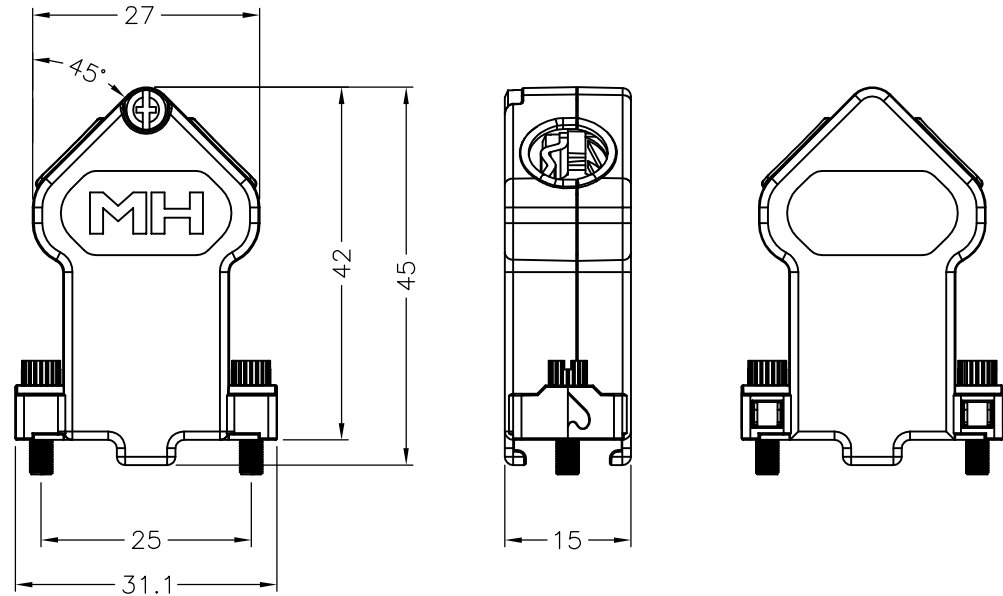
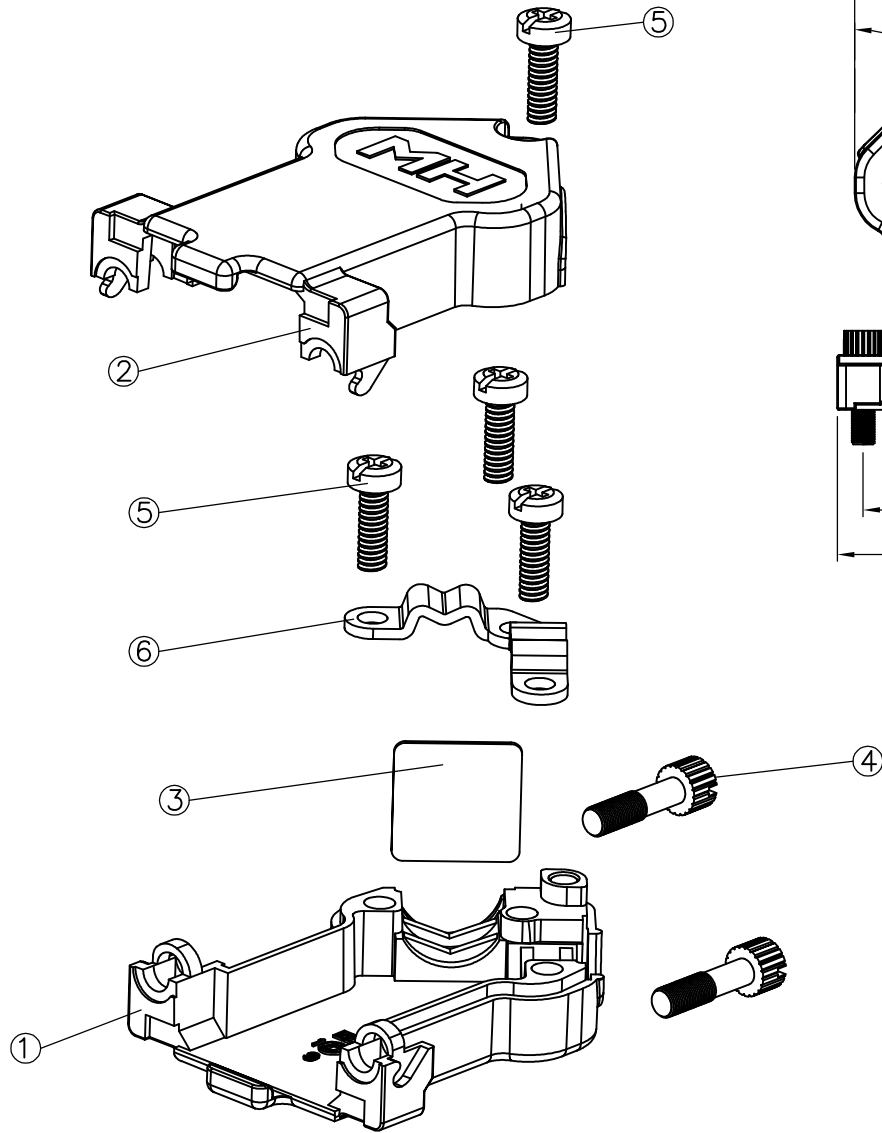

RECOMMENDED CABLE DIAMETER: 4.8mm–9mm

With MH Logo =MHDU45ZK9-K  
Without MH Logo =MHDU45ZK9-NL-K

ITEM	DESCRIPTION	MATERIALS	No.	PLATING
06	CABLE CLAMP	STEEL	1	ZINC PLATED
05	SCREW M2.5X7.5	STEEL	4	ZINC PLATED
04	MOUNTING SCREW UNC 4–40	STEEL	2	ZINC PLATED
03	DUMMY PLATE	STEEL	1	ZINC PLATED
02	TOP COVER	ZINC ALLOY	1	NICKEL PLATED
01	BOTTOM COVER	ZINC ALLOY	1	NICKEL PLATED

THESE DRAWINGS AND SPECIFICATIONS ARE THE PROPERTY OF MH CONNECTORS AND SHALL NOT BE REPRODUCED, COPIED OR USED AS THE BASIS FOR THE MANUFACTURE OR SALE OF APPARATUS WITHOUT WRITTEN PERMISSION.

DRAWN Haley Hu	DATE 03–18–15
APPROVED Victor Lin	DATE 03–18–15



THIS SERIES FULLY CONFORMS TO THE EUROPEAN UNION DIRECTIVES 2002/95/EC AND 2002/96/EC FOR RoHS COMPLIANCY.



MH CONNECTORS,  
DIVISION OF EDAC

SCALE 1 : 1	SHEET OF 1 OF 1	REV: 3.0
----------------	--------------------	-------------

DRAWING No  
MHDU45ZK9–K