



达林顿光耦
Darlington Photo Coupler

AT6N139

Product Data Sheet

AOTE DCC
RELEASE

台湾奥特半导体科技有限公司

TAIWAN AOTE SEMICONDUCTOR TECHNOLOGY CO.,LTD

www.aotesemi.com

概述 Description

AT6N139 通过发光二极管和集成高增益光检测器提供输入与输出之间高电流传输比。0.5 mA 的 LED 电流在 0 至 70°C 的工作温度范围内可保证 400% 的最小电流传输比。可适用于 CMOS、LSTTL 或其他低功耗应用中。

The AT6N139 uses a Light Emitting Diode and an integrated high gain photodetector to provide extremely high current transfer ratio between input and output. A 400% minimum current transfer ratio is guaranteed over 0 to 70°C operating range for only 0.5 mA of LED current. It can be used in CMOS, LSTTL or other low power applications.

特性 Features

- 高电流传输比：典型值 2000%
High current transfer ratio: 2000% typical
- 低输入电流要求：0.5mA
Low input current requirements: 0.5 mA
- TTL 兼容输出：V_{OL} 典型值 0.1V
TTL compatible output : 0.1 V VOL typical
- 基极接入实现带宽增益的调节
Base access allows gain bandwidth adjustment
- 高输出电流：60mA
High output current: 60 mA
- 符合安规标准：UL 1577，VDE DIN EN60747-5-5 (VDE 0884-5)，CQC11-471543-2022
Meet Safety standard I: UL 1577, VDE DIN EN60747-5-5 (VDE 0884-5)，CQC11-471543-2022

应用 Applications

- 低输入电流接口
Low input current line receiver
- EIA RS-232C 接口
EIA RS-232C line receiver
- 117 V 交流电压状态指示器
117 V ac line voltage status indicator
- 低功耗系统 – 接地隔离
Low power systems – ground isolation

真值表 Truth table

LED	VO
OFF	H
ON	L

封装和原理图 Package and Schematic Diagram



DIP8



SMD8

注意: 必须在引脚 5 和 8 之间连接 0.1uF 旁路电容。

Note: A 0.1uF bypass capacitor must be connected between pins 5 and 8.

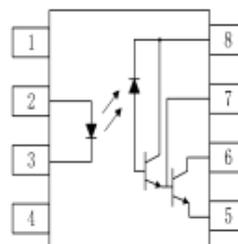

Pin Configuration

- | | |
|------------|-------|
| 1.NC | 8.VCC |
| 2. Anode | 7.VB |
| 3. Cathode | 6.VO |
| 4. NC | 5.GND |

产品型号命名规则 Order Code
AT 6N139 - UN Y - W (V) (ZZ)

① ② ③ ④ ⑤ ⑥ ⑦

- ① 公司代码 Company Code (AT: 奥特 Aote)
- ② 产品系列 Product Series (6N139)
- ③ 框架类型 Lead Frame (Cu: 铜框架 Copper)
- ④ 树脂类型 Epoxy Type (H: 无卤 Halogen-free)
- ⑤ 封装形式 Package (D: DIP ; S: SMD)
- ⑥ 器件工作温度范围 Device Operating Temperature Range (特殊范围需填或者空白 Special Range need to be filled in or left blank)
- ⑦ 内部补充代码 Internal Supplementary Code (数字或者空白 Number or None)

印字信息 Marking Information

- 印字中 “” 为奥特品牌 LOGO
“” denotes LOGO
- 印字中 “Y” 代表年份 ; A(2018),B(2019),C(2020)
“Y” denotes YEAR : A(2018), B(2019), C(2020)
- 印字中 “WW” 代表周号
“WW” denotes Week’ s number
- 印字中 “E” 代表内部代码
“E” denotes Internal code
- 印字中的 “H” 代表无卤
“H” denotes Halogen-free



绝缘和安规信息 Insulation and Safety related specifications

项目 Item	符号 Symbol	数值 Value	单位 Unit	备注 Remark
爬电距离 Creepage Distance	L	> 7.6	mm	从输入端到输出端，沿本体最短距离路径 Measured from input terminals to output terminals, shortest distance path along body
电气间隙 Clearance Distance	L	> 7.6	mm	从输入端到输出端，通过空气的最短距离 Measured from input terminals to output terminals, shortest distance through air
绝缘距离 Insulation Thickness	DTI	> 0.4	mm	发射器和探测器之间的绝缘厚度 Insulation thickness between emitter and detector
峰值隔离电压 Peak Isolation Voltage	V_{IORM}	1500	V_{peak}	DIN/EN/IEC EN60747-5-5
瞬态隔离电压 Transient isolation voltage	V_{IOTM}	7000	V_{peak}	DIN/EN/IEC EN60747-5-5
隔离电压 Isolation Voltage	V_{iso}	> 5000	Vrms	For 1 min

极限参数 Absolute Maximum Ratings (Ta = 25°C)

参数 Parameter		符号 Symbol	最小值 Min	最大值 Max	单位 Unit
发射端 Input	平均输入电流 Average Forward Input Current	$I_{F(AVG)}$	-	20	mA
	峰值输入电流 Peak Forward Input Current (50% Duty Cycle, 1 ms Pulse Width)	I_{FPK}	-	40	mA
	峰值瞬态输入电流 Peak Transient Input Current ($< 1 \mu s$ Pulse Width, 300 pps)	$I_{F(TRAN)}$	-	1.0	A
	反向电压 Reverse Voltage	V_R	-	5	V
	功耗 Input Power Dissipation	P_I	-	35	mW
接收端 output	输出电流 Output Current (Pin 6)	I_O	-	60	mA
	发射极-基极反向电压 Emitter Base Reverse Voltage (Pin 5-7)	V_{EB}	-	0.5	V
	电源电压和输出电压 Supply Voltage and Output Voltage	V_{CC}	-0.5	18	V
	输出功率 Output Power Dissipation	P_O	-	100	mW
总功率 Total Power Dissipation	P_T	-	135	mW	
工作温度 Operating Temperature	T_{opr}	-40	+85	°C	
存储温度 Storage Temperature	T_{stg}	-55	+125	°C	

推荐操作条件 Recommended Operating Conditions

参数 Parameter	符号 Symbol	最小值 Min	最大值 Max	单位 Unit
电源电压 Power Supply Voltage	V_{CC}	4.5	18	V
开启电流 Forward Input Current (ON)	$I_{F(ON)}$	0.5	12.0	mA
关断电压 Forward Input Voltage (OFF)	$V_{F(OFF)}$	0	0.8	V
操作温度 Operating Temperature	T_A	-40	+85	°C

特性参数 Electro-optical Characteristics (Ta = 25°C)

参数 Parameter	符号 Symbol	条件 Condition	最小 Min.	典型 Typ.	最大 Max.	单位 Unit	
发射端 Input	正向电压 Forward Voltage	$I_F = 1.6 \text{ mA}$	-	1.40	1.75	V	
		$T_A = 25^\circ\text{C}, I_F = 1.6 \text{ mA}$	1.25	1.40	1.7		
	反向击穿电压 Reverse Breakdown Voltage	BV_R	$I_R = 10 \mu\text{A}, T_A = 25^\circ\text{C}$	5.0	-	-	V
	电容 Capacitance	C_{IN}	$V = 0, f = 1 \text{ MHz}$	-	60	-	pF
正向电压的温度系数 Diode Temperature Coefficient	$\Delta V_F / \Delta T_A$	$I_F = 1.6 \text{ mA}$	-	-1.8	-	mV/°C	
接收端 Output	低电平电源电流 Low Level Supply Current	I_{CCL}	$I_F = 1.6 \text{ mA}, V_O = \text{Open}, V_{CC} = 18 \text{ V}$	-	0.4	1.5	mA
	高电平电源电流 High Level Supply Current	I_{CCH}	$I_F = 0 \text{ mA}, V_O = \text{Open}, V_{CC} = 18 \text{ V}$	-	0.01	10	μA
传输特性 Transfer Characteristics	低电平输出电压 LOW Level Output Voltage	V_{OL}	$I_F = 0.5 \text{ mA}, I_O = 2 \text{ mA}, V_{CC} = 4.5 \text{ V}$	-	0.1	0.4	V
			$I_F = 1.6 \text{ mA}, I_O = 8 \text{ mA}, V_{CC} = 4.5 \text{ V}$				
			$I_F = 5.0 \text{ mA}, I_O = 15 \text{ mA}, V_{CC} = 4.5 \text{ V}$				
			$I_F = 12 \text{ mA}, I_O = 24 \text{ mA}, V_{CC} = 4.5 \text{ V}$				
	高电平输出电流 HIGH Level Output Current	I_{OH}	$V_O = V_{CC} = 18 \text{ V}, I_F = 0 \text{ mA}$	-	0.05	100	μA
	电流传输比* Current Transfer Ratio	CTR	$I_F = 0.5 \text{ mA}, V_{CC} = 4.5 \text{ V}, V_O = 0.4 \text{ V}$	400	2000	-	%
$I_F = 1.6 \text{ mA}, V_{CC} = 4.5 \text{ V}, V_O = 0.4 \text{ V}$			500	1600	-	%	
隔离电压 Isolation Voltage	V_{ISO}	$RH < 50\%, t = 1 \text{ min.}, T_A = 25^\circ\text{C}$	5000	-	-	Vrms	
电阻 (输入到输出) Resistance (Input to Output)	R_{I-O}	$V_{I-O} = 500 \text{ Vdc}, RH < 45\%$	-	10^{12}	-	Ω	
电容 (输入到输出) Resistance (Input to Output)	C_{I-O}	$f = 1 \text{ MHz}$	-	0.6	-	pF	

 注*：电流传输比 = $I_C / I_F \times 100\%$ 。

 Note*：CTR = $I_C / I_F \times 100\%$ 。

开关特性 Switching Specification

Over recommended operating conditions ($T_A = 0$ to $+70^\circ\text{C}$), $V_{CC} = 5\text{V}$, unless otherwise specified.

参数 Parameter	符号 Symbol	条件 Condition	最小 Min.	典型 Typ.	最大 Max.	单位 Unit
输出高电平传播延迟 Propagation Delay Time to High Output Level	t_{PHL}	$I_F = 0.5\text{ mA}$, $R_I = 4.7\text{ k}\Omega$	-	5	30	μs
		$I_F = 0.5\text{ mA}$, $R_I = 4.7\text{ k}\Omega$ $T_A = 25^\circ\text{C}$	-	5	25	μs
		$I_F = 12\text{ mA}$, $R_I = 270\ \Omega$	-	0.2	2	μs
		$I_F = 12\text{ mA}$, $R_I = 270\ \Omega$ $T_A = 25^\circ\text{C}$	-	0.2	1	μs
输出低电平传播延迟 Propagation Delay Time to Low Output Level	t_{PLH}	$I_F = 0.5\text{ mA}$, $R_I = 4.7\text{ k}\Omega$	-	18	90	μs
		$I_F = 0.5\text{ mA}$, $R_I = 4.7\text{ k}\Omega$ $T_A = 25^\circ\text{C}$	-	18	60	μs
		$I_F = 12\text{ mA}$, $R_I = 270\ \Omega$	-	2	10	μs
		$I_F = 12\text{ mA}$, $R_I = 270\ \Omega$ $T_A = 25^\circ\text{C}$	-	2	7	μs
输出高电平共模瞬态抑制 Common Mode Transient Immunity at High Output Level	$ CM_H $	$I_F = 0\text{ mA}$, $T_A = 25^\circ\text{C}$ $R_I = 2.2\text{ k}\Omega$, $ V_{CM} = 10\text{Vp-p}$	1000	10000	-	$\text{V}/\mu\text{s}$
输出低电平共模瞬态抑制 Common Mode Transient Immunity at Low Output Level	$ CM_L $	$I_F = 1.6\text{ mA}$, $T_A = 25^\circ\text{C}$ $R_I = 2.2\text{ k}\Omega$, $ V_{CM} = 10\text{Vp-p}$	1000	10000	-	$\text{V}/\mu\text{s}$

典型光电特性曲线 Typical Electro-Optical Characteristics Curves

Fig.1 Output current vs. Output Voltage

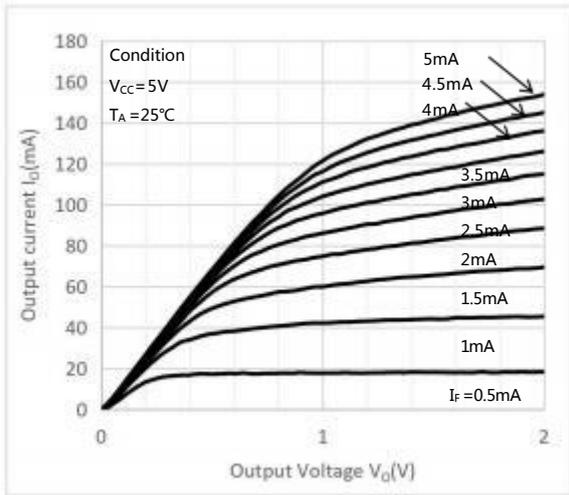

Fig.2 Current transfer ratio vs. Input current

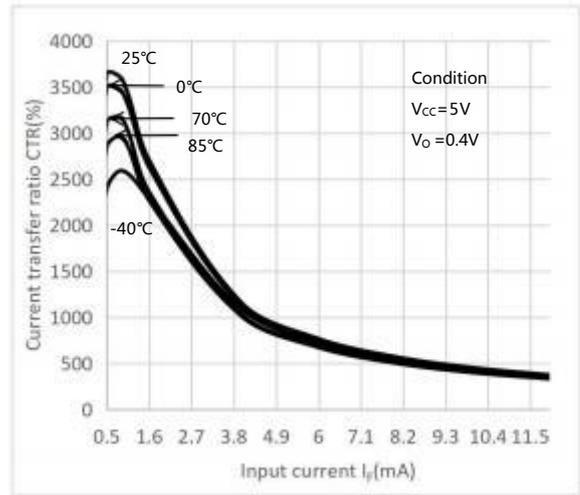

Fig.3 Output current vs. Input current

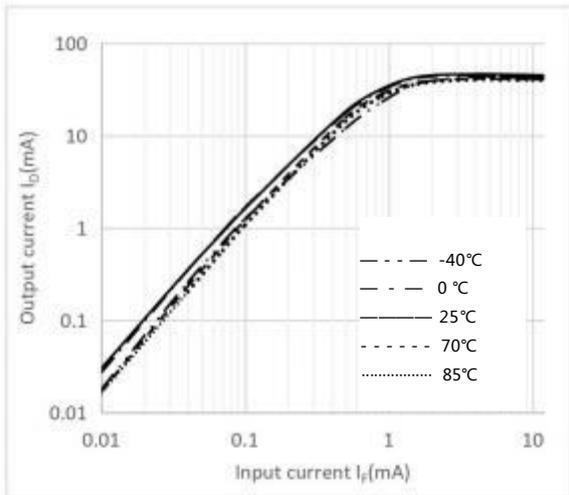

Fig.4 Input current vs. Forward Voltage

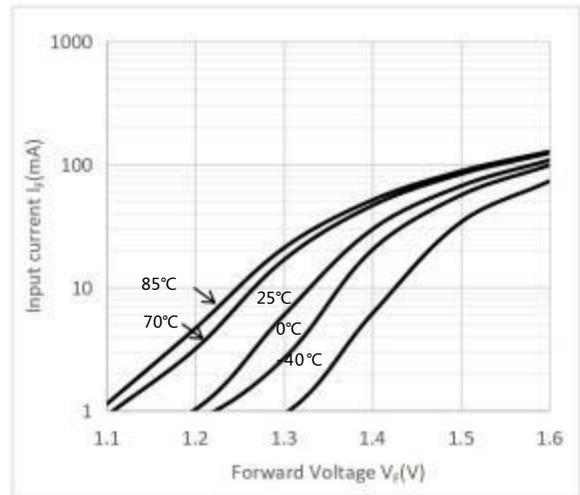

Fig.5 Propagation delay vs. Ambient temperature

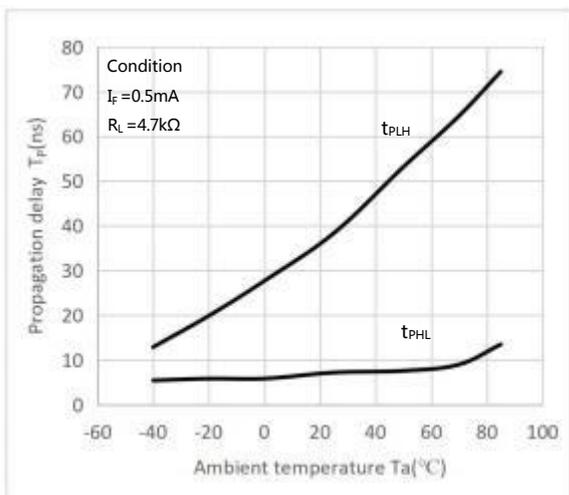

Fig.6 Propagation delay vs. Ambient temperature

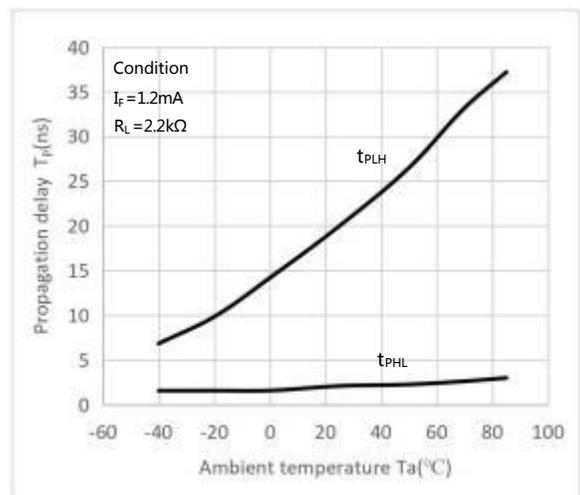

Fig.7 Propagation delay vs. Ambient temperature

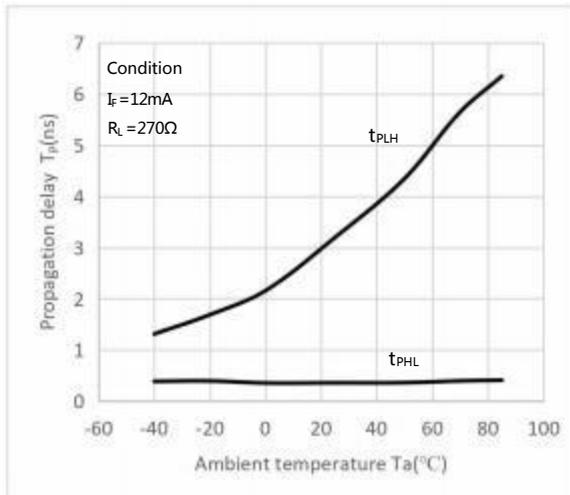

Fig.8 Forward Voltage vs. Ambient temperature

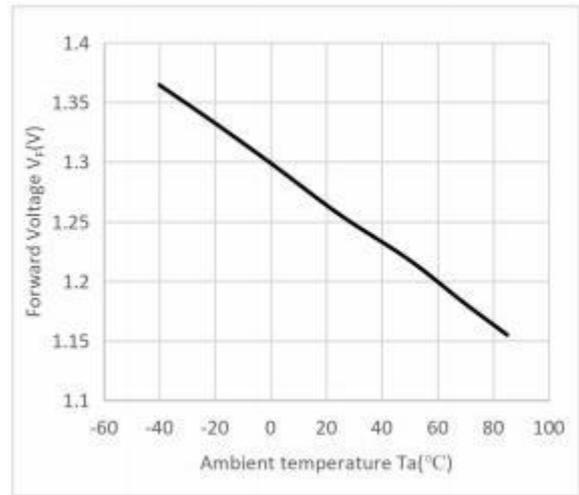
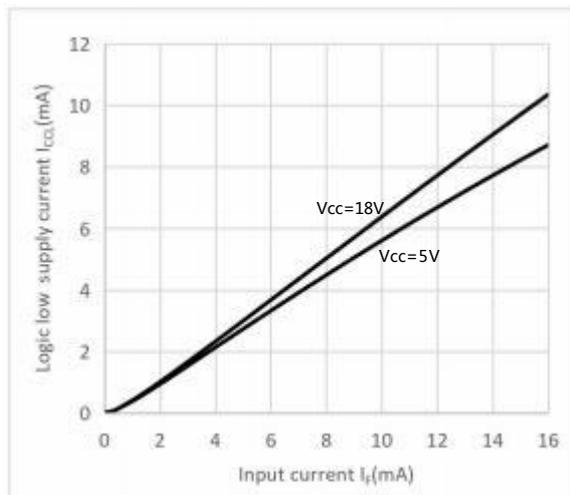
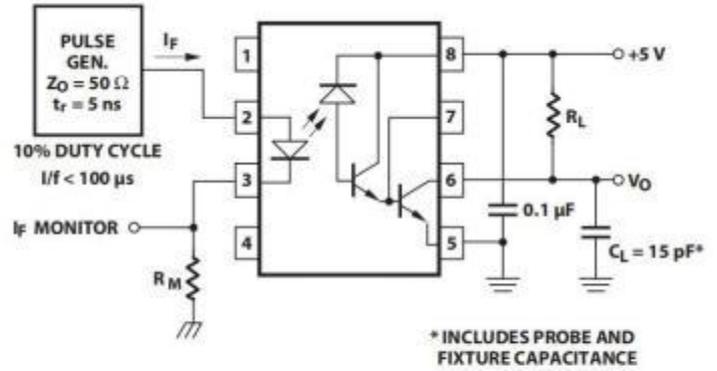
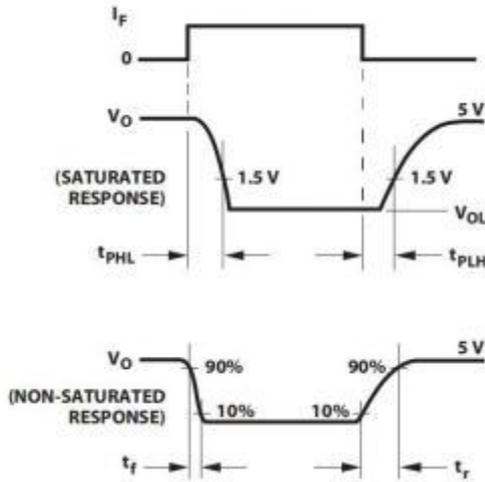

Fig.9 Logic low supply current vs. Input current



开关时间测试电路 Witch Time Test Circuit



CMR 测试电路 Test Circuit for Common Mode Transient Immunity

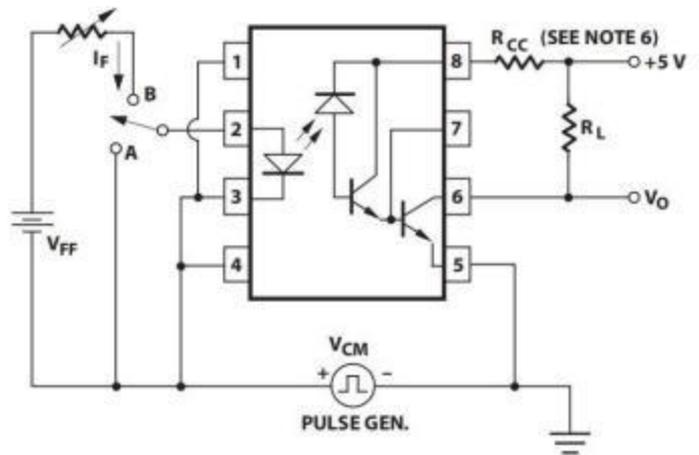
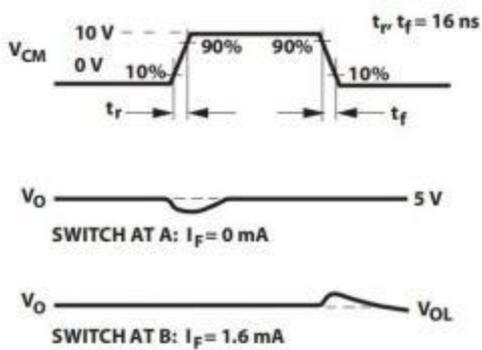

外形尺寸 Outline Dimensions

DIP8

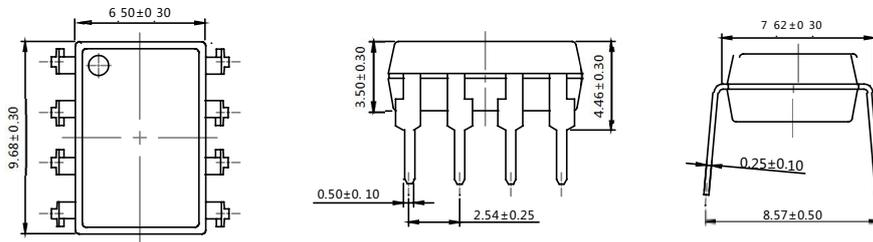

SMD8

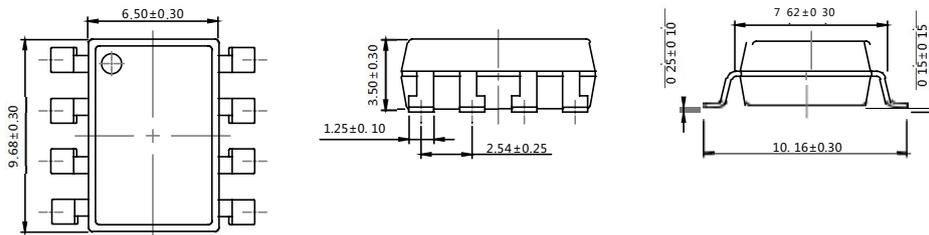

单位 Unit: mm

建议焊盘布局 Recommended Pad Layout

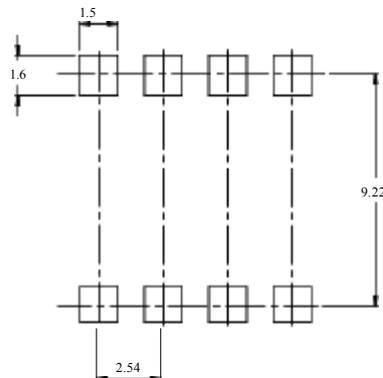

单位 Unit: mm

注：上图为产品正视图。

Note: The picture above is the front view of the product.

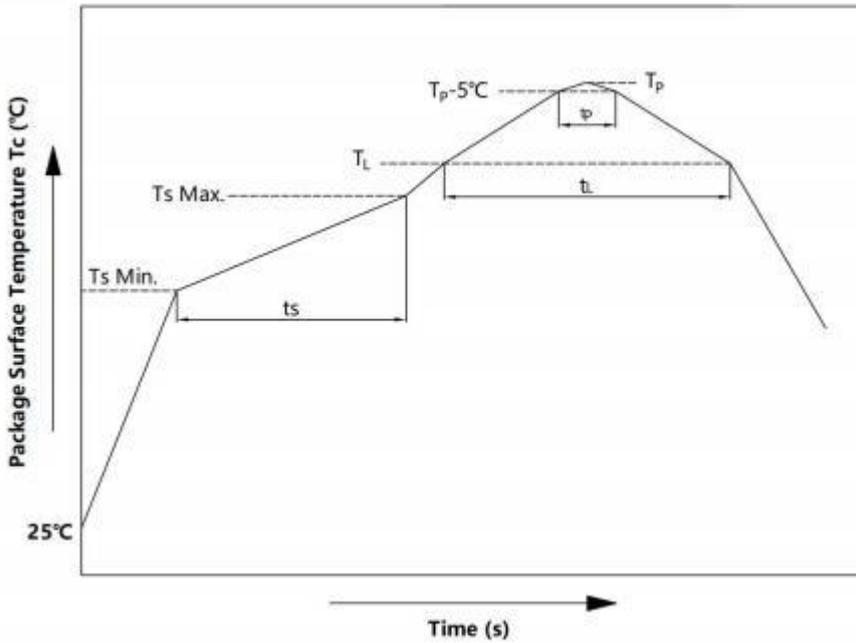
回流焊温度曲线图 Solder Reflow Profile

项目 Item	符号 Symbol	最小值 Min.	最大值 Max.	单位 Unit
预热温度 Preheat Temperature	Ts	150	200	°C
预热时间 Preheat Time	ts	60	120	s
升温速率 Ramp-Up Rate (T _L to T _P)	-	-	3	°C/s
液相线温度 Liquidus Temperature	T _L	217		°C
时间高于 T _L Time Above T _L	t _L	60	150	s
峰值温度 Peak Temperature	T _P	-	260	°C
Tc 在(T _P -5)和 T _P 之间的时间 Time During Which Tc Is Between (T _P -5) and T _P	t _p	-	30	s
降温速率 Ramp-down Rate(T _P to T _L)	-	-	6	°C/s

注 Note :

建议在所示的温度和时间条件下进行回流焊，最多不能超过三次；

Reflow soldering is recommended at the temperatures and times shown, no more than three times;

波峰焊温度曲线图 Wave Soldering Profile

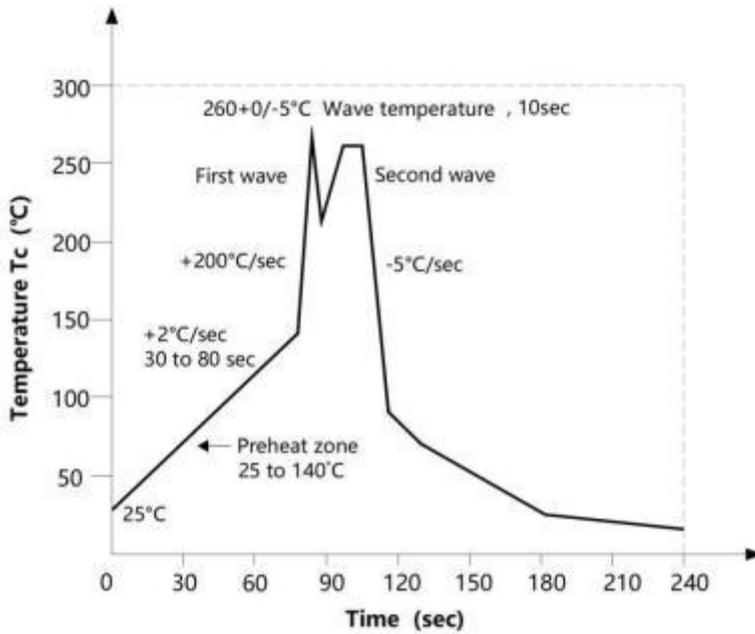

手工烙铁焊接 Soldering with hand soldering iron

- A. 手工烙铁焊仅用于产品返修或样品测试；
Hand soldering iron is only used for product rework or sample testing;
- B. 手工烙铁焊要求：温度 $360^{\circ}\text{C} \pm 5^{\circ}\text{C}$ ，时间 $\leq 3\text{s}$ 。
Hand soldering iron requirements：Temperature： $360^{\circ}\text{C} \pm 5^{\circ}\text{C}$, within 3s

包装 Packing

■ 汇总表 Summary table

封装形式	包装方式	盘数量	盒数量	箱数量	静电袋规格	盒规格	箱(双瓦楞)规格	备注
SMD8	卷盘 ($\phi 330\text{mm}$ 蓝盘)	1k/盘	2 盘/盒	10 盒/箱	450*390*0.1mm	340*60*340mm	380*360*365mm	首端空 50 个空格， 末端空 100
DIP8	管装 (500*12*11mm)	45/管	50 管/盒	10 盒/箱	不适用	525*128*56mm	535*275*300mm	每管使用蓝白胶塞， 方向须一致
Package Type	Packing Form	Quantity per Reel	Quantity per Box	Quantity per Carton	Antistatic Bag Specification	Box Specification	Carton Specification	Note
SMD8	Reel ($\phi 330\text{mm}$ Blue)	1Kpcs/reel	2reels/box	10boxes /ctn	450*390*0.1mm	340*60*340mm	620*360*365 mm	Leave 50 Spaces at the beginning and 100 Spaces at the end
DIP8	Tube (500*12*11mm)	45pcs /tube	50tubes /box	10boxes /ctn	NA	525*128*56mm	535*275*300 mm	Endplug (blue) and Endplug (white) keep the direction

■ 条管包装 Tube

- 1) 每箱数量：22500 只。
Qty/ctn：22500pcs
- 2) 内包装：Inner packing：
 - i. 每条管 45 只。
45pcs/tube
 - ii. 每盒 50 条管。
50 tubes/box
- 3) 示意图 Schematic：

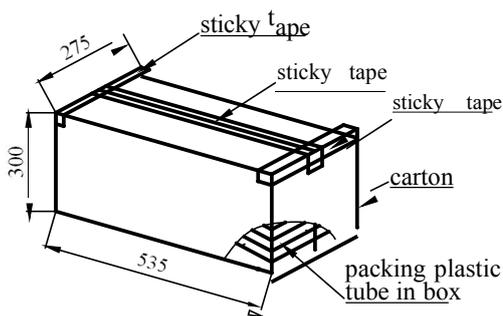

■ 编带包装 Tape & Reel

- 1) 每卷数量：1000 只。
Qty/reel：1000 pcs.
- 2) 每箱数量：20000 只。
Qty/ctn：20000 pcs.
- 3) 内包装：每盒 2 盘。
Inner packing：2 reels/box.
- 4) 示意图 Schematic：

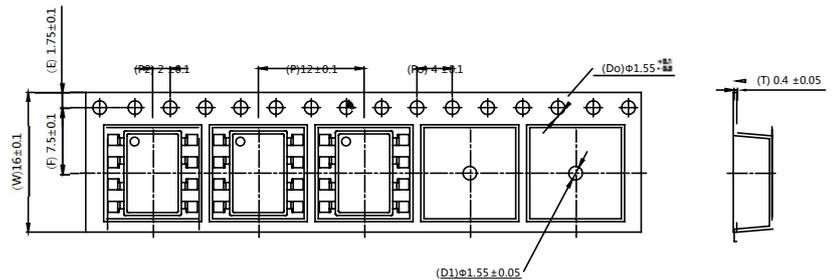

单位 Unit：mm

注意 Attention

- 奥特持续不断改进质量、可靠性、功能或设计，保留此文件更改的权利恕不另行通知。
AOTE continuously improve quality, reliability, function and design. We reserve the right to change this document without prior notice.
- 请遵守产品规格书使用，奥特不对使用时不符合产品规格书条件而导致的质量问题负责。
Please use in accordance with the product specification. AOTE is not responsible for the quality problems caused by non-compliance with the product specifications.
- 对于需要高可靠性或安全性的设备/装置需求，请联系我们的销售人员。
For equipment/devices requiring high reliability or safety, please contact our sales representatives.
- 当需要用于任何“特定”应用时，请咨询我们的销售人员。
When requiring a device for any “specific” application, please contact our sales in advice.
- 如对文件中表述的内容有疑问，欢迎联系我们。
If you have any questions about the contents of the document, please contact us.