

CIRCUIT DIAGRAM

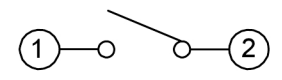

SPECIFICATION

Contact Rating 50mA, 12V DC  
 Contact Resistance 100mΩ max  
 Insulation Resistance 100mΩ min. 500V DC  
 Dielectric Strength 250V AC/1minute  
 Travel 0.25mm  
 Operating Temp -30 ~+85  
 Storage Temp -30 ~+80

H	H1	H2	ØA	L
A1	3.15	4.3	3.5	3.7
AS	3.35	4.5	3.5	
A	3.85	5.0	3.5	
AL	4.35	5.5	3.4	
Q	4.85	6.0	3.4	
QL	5.35	6.5	3.4	
B	5.85	7.0	3.4	
E	6.15	7.3	3.4	
EL	6.35	7.5	3.4	
C	6.85	8.0	3.4	
CL	7.35	8.5	3.4	
DS	7.85	9.0	3.4	
D	8.35	9.5	3.4	
DL	8.85	10.0	3.0	
KS	9.35	10.5	3.0	
K	9.85	11.0	3.0	
KL	10.35	11.5	3.0	
FS	10.85	12.0	3.0	
F	11.35	12.5	3.0	
FL	11.85	13.0	3.0	
G	12.35	13.5	3.0	
O	12.85	14.0	3.0	
X	13.35	14.5	3.0	
Y	13.85	15.0	3.0	
Z	14.85	16.0	3.0	
J	15.15	16.3	3.0	
I	15.85	17.0	3.0	

P.C.B MOUNTING PATTERN DIMENSION

The following soldering patterns are recommended for reflow soldering

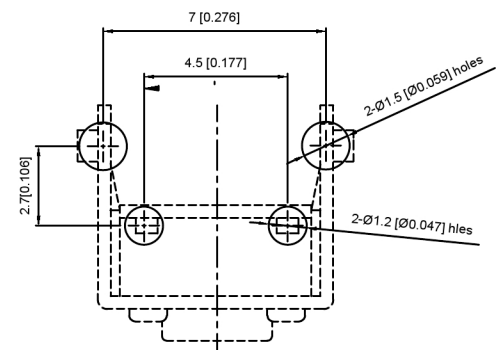
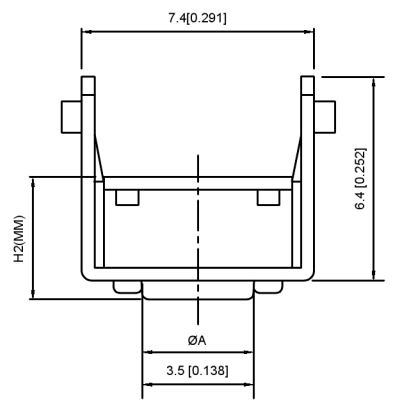

PAPT NO	TC-1102N-X-X-X
Operating Force	A:100gf B:160gf C:260gf D:450gf
Height	H
Color	B:Black BR:Brown R:Red O:Orange G:Green Y:Yellow BL:Blue W:White

ITEM	PAPT NAMF	TER.NO	QTY	MATERIAL	FINISHING	REMARK
⑤	Terminal	—	2	Brass 0.30t	Plating silvering	—
④	Contact	—	1	F.ag/Sus	Natural	—
③	Base	—	1	Ppa		—
②	Cover	—	1	Spcc	Plating Nickel	—
①	Keystake	—	1	Ppa		—

DSND		DATE		SCALE: N/A	MODEL TYPE: TACT SWITCH
DWN		DATE		VIEW:	PART NO.:
CHKD		DATE		UNIT: mm/in	DWG NO.:
APPD		DATE		SIZE: A4	TC-1102N-X-X-X
				XKB INDUSTRIAL PRECISION CO., LIMITED	WEIGHT 1.0g
					SHEET 1/1
					REVISION A0

MARK	DESCRIPTION	DATE	REVISED	APPROVED	units: mm	tolerance:
ΔX					X.X	±0.2mm
ΔX					X.XX	±0.1mm
ΔX					X.XXX	±0.05mm
						UNSPECIFIED TOLERANCES