

CIRCUIT DIAGRAM

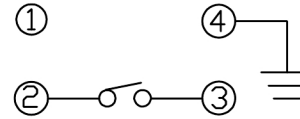

Code-x	H(mm)	H1(mm)	∅(mm)
A	4.3	3.15	3.5
B	4.5	3.35	3.5
C	5.0	3.85	3.5
D	5.5	4.35	3.5
E	6.0	4.85	3.5
F	6.5	5.35	3.4
G	7.0	5.85	3.4
H	7.5	6.35	3.3
I	8.0	6.85	3.3
J	8.5	7.35	3.3
K	9.0	7.85	3.1
L	9.5	8.35	3.1
M	10.0	8.85	3.1
N	10.5	9.35	3.0

Code-x	H(mm)	H1(mm)	∅(mm)
O	11.0	9.85	3.0
P	11.5	10.35	3.0
Q	12	10.85	3.0
R	12.5	11.35	3.0
S	13.0	11.85	3.0
T	13.5	12.35	3.0
U	14.0	12.85	3.0
V	15.0	13.85	3.0
W	15.5	14.35	3.0
X	16	14.85	3.0
Y	17	15.85	3.0
Z	18	16.85	3.0
19	19	17.85	3.0

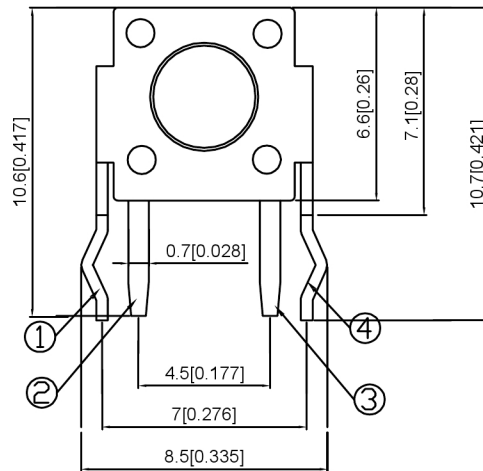
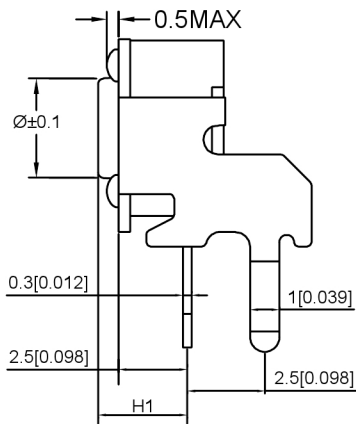

SPECIFICATION

Contact Rating: 50mA, 12V DC
 Contact Resistance: 100mΩ max
 Insulation Resistance: 100mΩ min. 500V DC
 Dielectric Strength: 250V AC/1minute
 Travel: 0.25mm
 Operating Temp: -30°C ~ +85°C
 Storage Temp: -30°C ~ +80°C

PAPT NO	TC-1102HJ-X-X
Operating Force	A:100gf B:160gf C:260gf
Height	Code-x

ITEM	PAPT NAMF	TER.NO	QTY	MATERIAL	FINISHING	REMARK
⑤	Terminal	—	2	Brass (0.30t)	Plating silvering	—
④	Contact	—	1	F.ag/Sus	Natural	—
③	Base	—	1	Pa46	—	—
②	Cover	—	1	Spcc	Plating Nickel	—
①	Keystake	—	1	Pa46	—	—

广东星坤科技股份有限公司

Δx	日期
Δx	日期
Δx	日期
MARK	DESCRIPTION

文件工程章

REVISIONS	DATE	REVISED	APPROVED	UNSPECIFIED TOLERANCES
ANGLAR				±5°
L ≤ 4				±0.2
4 < L ≤ 16				±0.3
16 < L ≤ 63				±0.4
L > 63				±0.5



DSND	SCALE: N/A
DWN	VIEW:
CHKD	UNIT: mm/in
APPD	SIZE: A4

MODEL TYPE:	TACT SWITCH	
PART NO.:	TC-1102HJ-X-X	
DWG NO.:		
WEIGHT	SHEET	REVISIC
	1/1	A0

XKB INDUSTRIAL PRECISION CO., LIMITED

www.helloxkb.com www.helloxkb.cn www.xk-dg.cn