

1. DESCRIPTION

XL62083 series are DMOS transistor array with 8 circuits. It has a clamp diode for switching inductive loads built-in in each output. Please be careful about thermal conditions during use.

2. FEATURES

- 8 circuits built-in
- High voltage :VOUT= 50 V (MAX)
- High current : IOUT = 500 mA/ch (MAX)
- Input voltage(output on) :XL62083 series 2.5 V (MIN)
- Input voltage(output off) :XL62083 series 0.6 V (MAX):
- Package SOP18

3. PIN CONFIGURATIONS AND FUNCTIONS

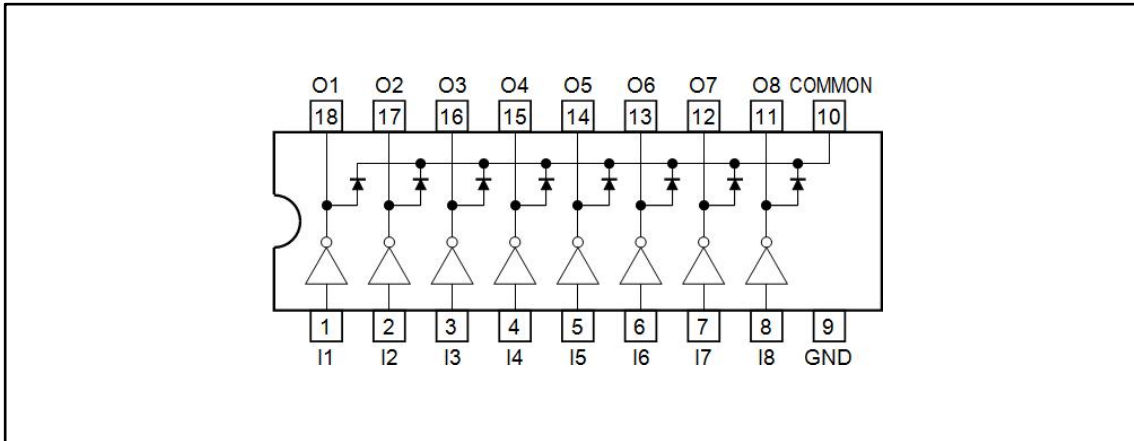

Pin connection may be simplified for explanatory purpose.

Pin Functions

Pin No.	Pin name	Function
1	I1	Input pin
2	I2	Input pin
3	I3	Input pin
4	I4	Input pin
5	I5	Input pin
6	I6	Input pin
7	I7	Input pin
8	I8	Input pin
9	GND	GND pin
10	COMMON	Common pin
11	O8	Output pin
12	O7	Output pin
13	O6	Output pin
14	O5	Output pin
15	O4	Output pin
16	O3	Output pin
17	O2	Output pin
18	O1	Output pin

4. EQUIVALENT CIRCUIT

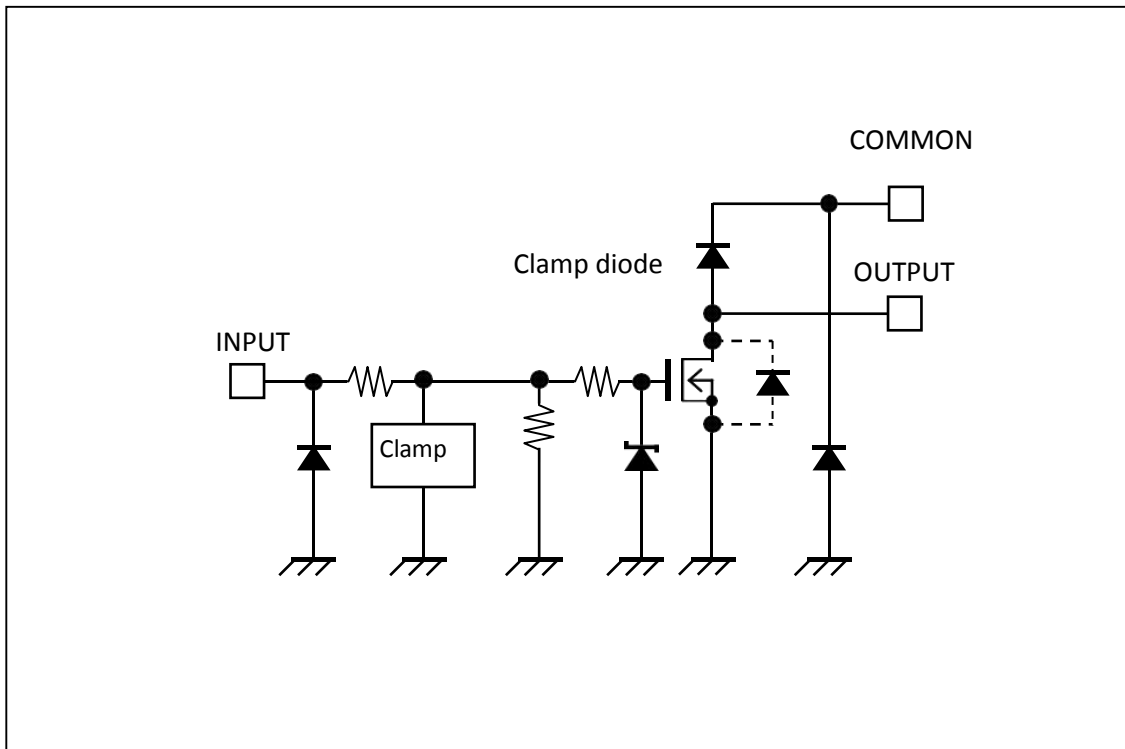

5. SPECIFICATIONS

5.1. Absolute Maximum Ratings(Ta = 25°C)

Characteristics		Symbol	Rating	Unit
Output voltage		V _{OUT}	50	V
COMMON pin voltage		V _{COM}	-0.5 to 50	V
Output current		I _{OUT}	500	mA/ch
Input voltage		V _{IN}	-0.5 to 30	V
Clamp diode reverse voltage		V _R	50	V
Clamp diode forward current		I _F	500	mA
Power dissipation	PG (Note1)	P _D	1.47	W
	FG (Note2)		0.96	
	FNG (Note3)		0.96	
	FWG (Note4)		1.31	
Operating temperature		T _{opr}	-40 to 85	°C
Storage temperature		T _{stg}	-55 to 150	°C

[1] Note1: Device alone. When Ta exceeds 25 °C, it is necessary to do the derating with 11.8 mW/°C.

[2] Note2: Device alone. When Ta exceeds 25 °C, it is necessary to do the derating with 7.7 mW/°C.

[3] Note3: On PCB (Size: 50 mm × 50 mm × 1.6 mm, Cu area: 40 %, single-side glass epoxy).

When Ta exceeds 25 °C, it is necessary to do the derating with 7.7 mW/°C.

[4] Note4: On PCB (Size: 75 mm × 114 mm × 1.6 mm, Cu area: 20 %, single-side glass epoxy).

When Ta exceeds 25 °C, it is necessary to do the derating with 10.48 mW/°C.

5.2.Recommended Operating Conditions

Characteristics		Symbol	Condition	Min	Typ.	Max	Unit	
Output voltage		V _{OUT}	—	—	—	50	V	
COMMON pin voltage		V _{COM}	—	0	—	50	V	
Output current	PG (Note1)	I _{OUT}	1 circuits ON, Ta = 25°C		0	—	400	mA/ch
			t _{pw} = 25 ms 8 circuits ON Ta = 85°C T _j = 120°C	Duty = 10%	0	—	390	
				Duty = 50%	0	—	170	
	FG (Note1)		1 circuits ON, Ta = 25°C		0	—	400	
			t _{pw} = 25 ms 8 circuits ON Ta = 85°C T _j = 120°C	Duty = 10%	0	—	320	
				Duty = 50%	0	—	140	
	FNG (Note2)	1 circuits ON, Ta = 25°C		0	—	400		
		t _{pw} = 25 ms 8 circuits ON Ta = 85°C T _j = 120°C	Duty = 10%	0	—	320		
			Duty = 50%	0	—	140		
	FWG (Note3)	1 circuits ON, Ta = 25°C		0	—	400		
		t _{pw} = 25 ms 8 circuits ON Ta = 85°C T _j = 120°C	Duty = 10%	0	—	370		
			Duty = 50%	0	—	160		
Input voltage (Output on)	XL62083 series	V _{IN} (ON)	I _{OUT} = 100 mA or upper, V _{OUT} = 2 V	2.5	—	25	V	
Input voltage (Output off)	XL62083 series	V _{IN} (OFF)	I _{OUT} = 100 μA or less, V _{OUT} = 2 V	0	—	0.6	V	
Clamp diode forward current		I _F	—	—	—	400	mA	

[1] Note1: Device alone.

[2] Note2: On PCB (Size: 50 mm × 50 mm × 1.6 mm, Cu area: 40%, single-side glass epoxy).

[3] Note3: On PCB (Size: 75 mm × 114 mm × 1.6 mm, Cu area: 20%, single-side glass epoxy).

5.3. Electrical Characteristics (Ta = 25°C unless otherwise noted)

Characteristics	Symbol	Test Circuit	Condition	Min	Typ.	Max	Unit	
Output leakage current	I _{leak}	1	V _{OUT} = 50V, Ta = 85°C V _{IN} = 0 V	—	—	1.0	μA	
			I _{OUT} = 350 mA, V _{IN} = 5.0V	—	0.7 (2.0)	1.14 (3.25)		
	XL62083A series		I _{OUT} = 200 mA, V _{IN} = 5.0V	—	0.4 (2.0)	0.65 (3.25)		
Output voltage (Output ON-resistance)	V _{DS} (R _{ON})	2	I _{OUT} = 100 mA, V _{IN} = 5.0V	—	0.2 (2.0)	0.325 (3.25)	V(Ω)	
			I _{OUT} = 350 mA, V _{IN} = 7.0V	—	0.7 (2.0)	1.14 (3.25)		
			I _{OUT} = 200 mA, V _{IN} = 7.0V	—	0.4 (2.0)	0.65 (3.25)		
			I _{OUT} = 100 mA, V _{IN} = 7.0V	—	0.2 (2.0)	0.325 (3.25)		
Input current (Output on)	XL62083 series	I _{IN} (ON)	3	V _{IN} = 2.5 V	—	—	0.1	mA
Input current (Output off)		I _{IN} (OFF)	4	V _{IN} = 0 V, Ta = 85°C	—	—	1.0	μA
Input voltage (Output on)	XL62083 series	V _{IN} (ON)	5	I _{OUT} = 100 mA, V _{OUT} = 2 V	—	—	2.5	V
Clamp diode reverse current	I _R	6	V _R = 50 V, Ta = 85°C	—	—	1.0	μA	
Clamp diode forward voltage	V _F	7	I _F = 350 mA	—	—	2.0	V	
Turn-on delay	t _{ON}	8	V _{OUT} = 50 V R _L = 125 Ω C _L = 15 pF	—	0.4	—	μs	
Turn-off delay	t _{OFF}			—	0.8	—		

5.4. Test circuit

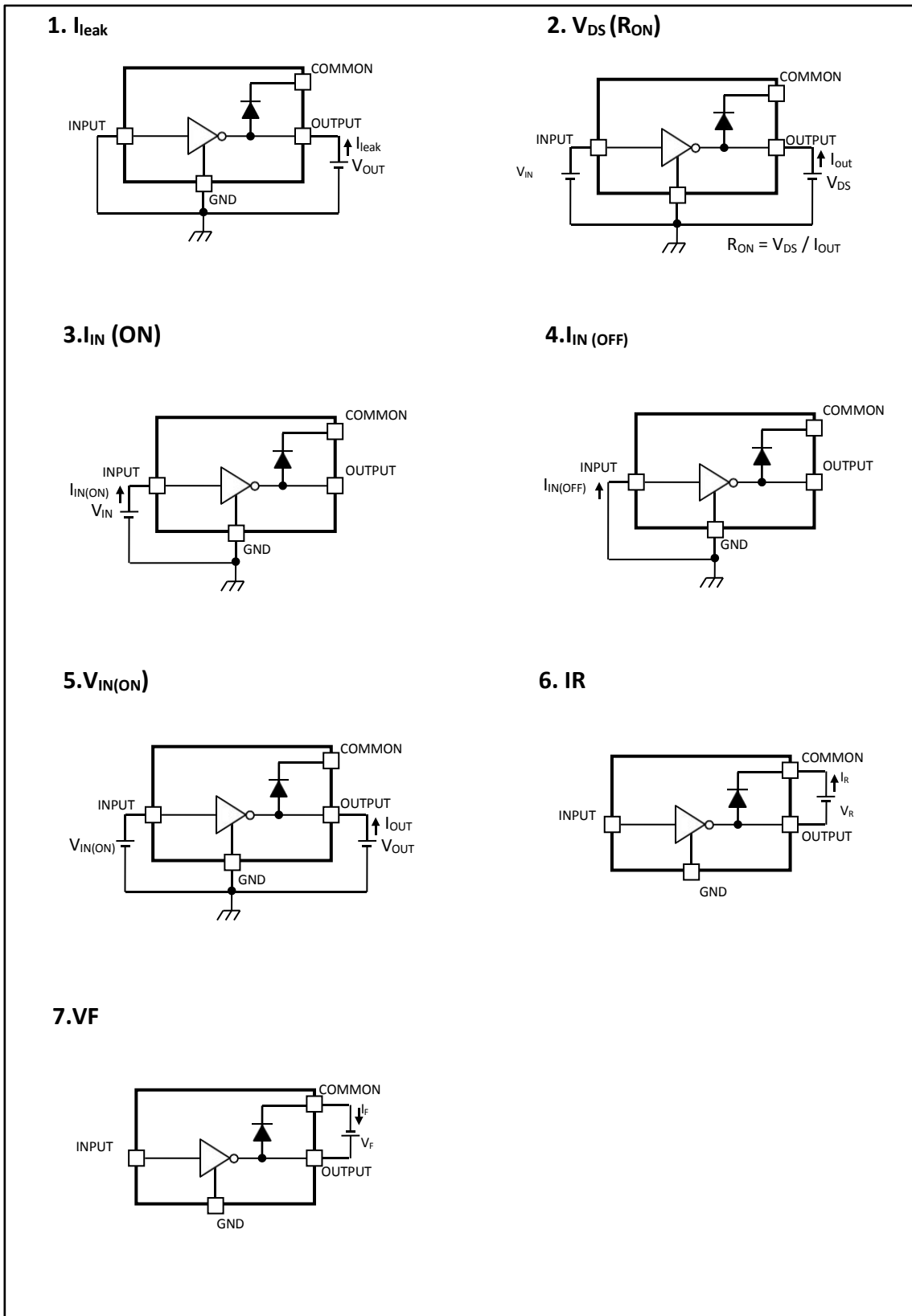

Test circuit may be simplified for explanatory purpose.

5.5. t_{ON}, t_{OFF}

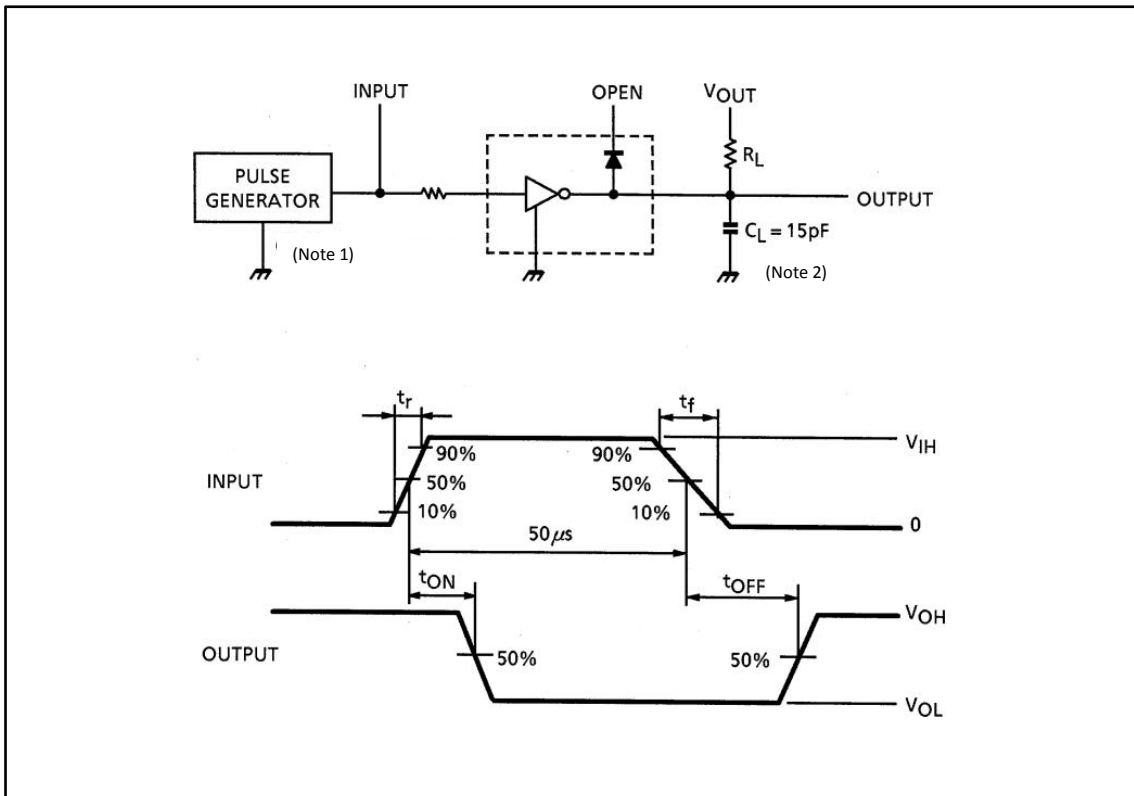

[1] Note 1: Pulse width 50 μ s, Duty cycle 10%

Output impedance 50 Ω , $t_r \leq 5$ ns, $t_f \leq 10$ ns

Please refer to the following table for the V_{IH} condition.

Product	V_{IH}
XL62083	5.0 V

[2] Note 2: C_L includes the probe and the test board capacitance.

[3] Test circuit and timing chart may be simplified for explanatory purpose.

Precautions for Using

This IC does not include built-in protection circuits for excess current or overvoltage. If this IC is subjected to excess current or overvoltage, it may be destroyed.

Hence, the utmost care must be taken when systems which incorporate this IC are designed.

Utmost care is necessary in the design of the output line, COMMON and GND line since IC may be destroyed due to short-circuit between outputs, air contamination fault, or fault by improper grounding.

6. ORDERING INFORMATION

Ordering Information

Part Number	Device Marking	Package Type	Body size (mm)	Temperature (°C)	MSL	Transport Media	Package Quantity
XL62083	XL62083	SOP18	11.45 * 7.50	- 40 to 85	MSL3	T&R	1000

7. DIMENSIONAL DRAWINGS

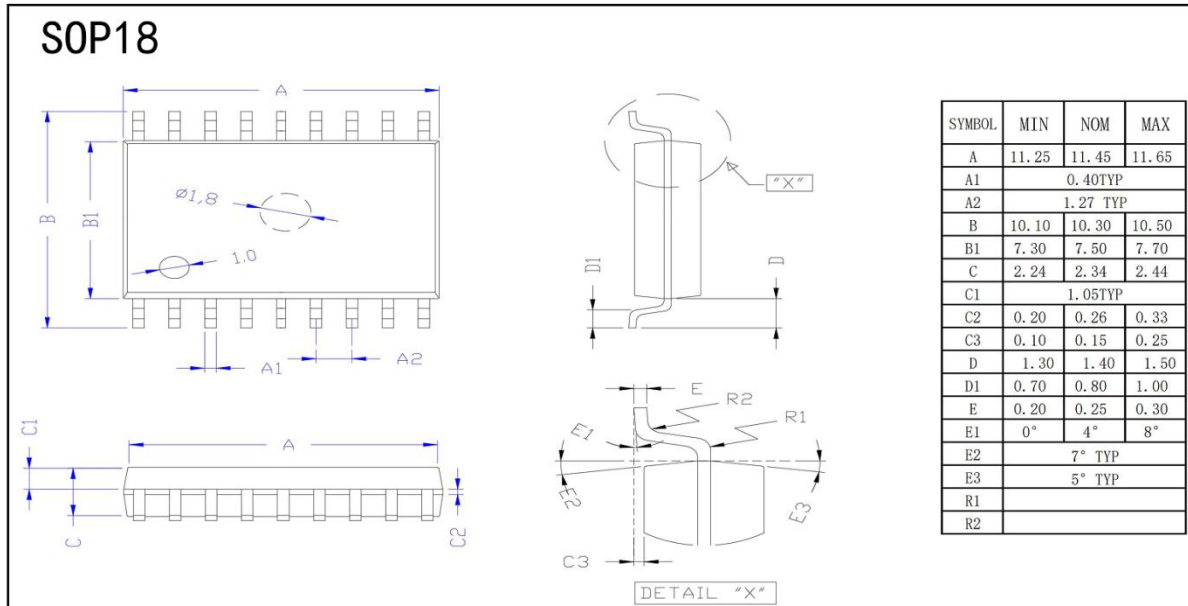

[if you need help contact us. Xinluda reserves the right to change the above information without prior notice]