

1. DESCRIPTION

The XL62783/XD62783 Series are comprised of eight source current Transistor Array.

These drivers are specifically designed for fluorescent display applications.

Applications include relay, hammer and lamp drivers.

2. FEATURES

- High output voltage: $V_{CC} = 50\text{ V}$ (min)
- Output current (single output): $I_{OUT} = -500\text{ mA}$ (max)
- Output clamp diodes
- Single supply voltage
- Input compatible with various types of logic
- Designation: TTL, 5V CMOS

3. PIN CONFIGURATIONS AND FUNCTIONS

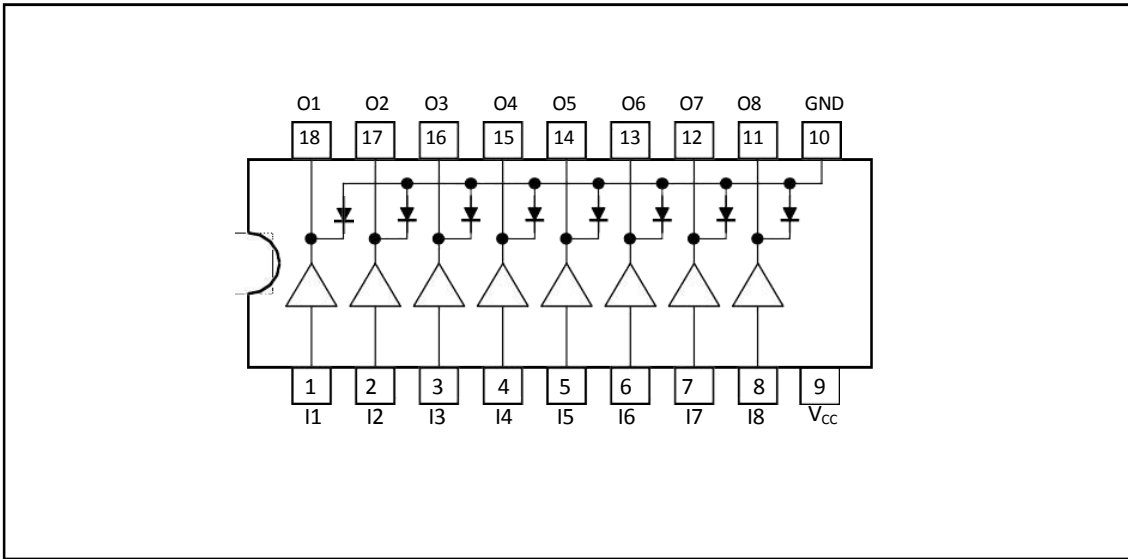

4. SCHEMATICS(each driver)

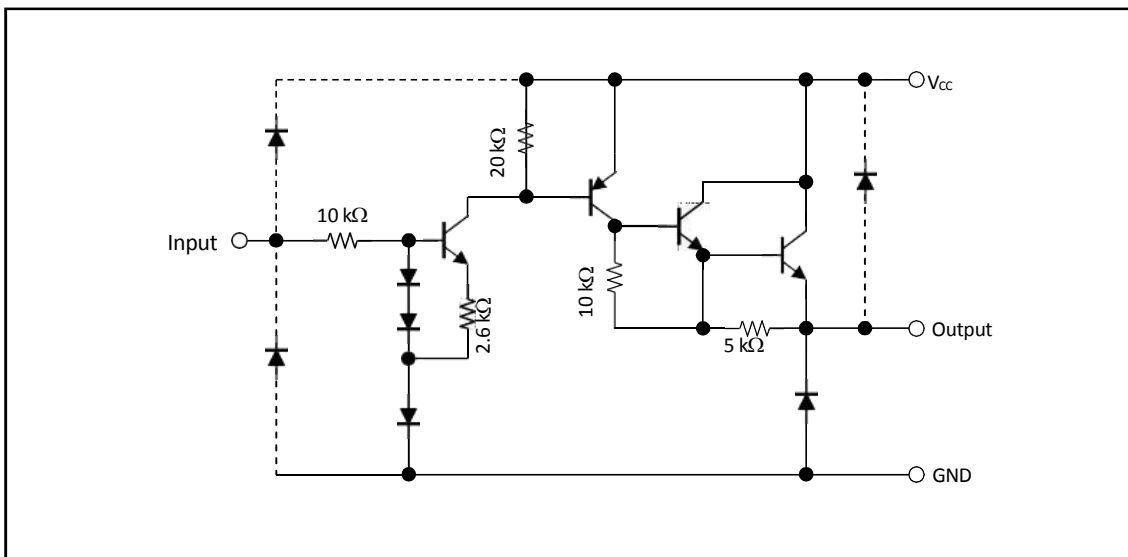

Note: The input and output parasitic diodes cannot be used as clamp diodes.

5. SPECIFICATIONS

5.1. Absolute Maximum Ratings (Ta = 25°C)

Characteristics		Symbol	Rating	Unit
Supply voltage		V _{CC}	50	V
Output current		I _{OUT}	-500	mA/ch
Input voltage		V _{IN}	15	V
Clamp diode reverse voltage		V _R	50	V
Clamp diode forward current		I _F	500	mA
Power dissipation	XD	PD (Note)	1.47	W
	XL		0.96	
Operating temperature		T _{opr}	-40 to 85	°C
Storage temperature		T _{stg}	-55 to 150	°C

5.2. Operating Ratings

Characteristics		Symbol	Rating	Unit
Supply voltage		V _{CC}	50	V
Output current		I _{OUT}	-500	mA/ch
Input voltage		V _{IN}	15	V
Clamp diode reverse voltage		V _R	50	V
Clamp diode forward current		I _F	500	mA
Power dissipation	XD	PD (Note)	1.47	W
	XL		0.96	
Operating temperature		T _{opr}	-40 to 85	°C
Storage temperature		T _{stg}	-55 to 150	°C

5.3. Electrical Characteristics (Ta = 25°C)

Characteristics	Symbol	Test Circuit	Test Condition	Min	Typ.	Max	Unit
Output leakage current	I _{CEX}	1	V _{CC} = V _{CC max} V _{IN} = 0.4 V Ta = 25°C	—	—	100	μA
Output saturation voltage	V _{CE (sat)}	2	V _{IN} = V _{IN (ON)} , I _O UT = -350 mA	—	—	2.0	V
			V _{IN} = V _{IN (ON)} , I _O UT = -225 mA	—	—	1.9	
			V _{IN} = V _{IN (ON)} , I _O UT = -100 mA	—	—	1.8	
Input current	I _{IN (ON)}	3	V _{IN} = 2.4 V	—	36	52	μA
			V _{IN} = 3.85 V	—	180	260	
Input voltage	V _{IN (ON)}	4	V _{CE} = 2.0 V, I _O UT = -350 mA	—	—	2.0	V
	V _{IN (OFF)}		I _O UT = -500 μA	0.8	—	—	
Supply current	I _{CC (ON)}	3	V _{IN} = V _{IN (ON)} , V _{CC} = 50 V	—	—	2.5	mA/ch
Clamp diode reverse current	I _R	5	V _R = 50 V	—	—	50	μA
Clamp diode forward voltage	V _F	6	I _F = 350 mA	—	—	2.0	V
Turn-ON delay	t _{ON}	7	V _{CC} = V _{CC max} R _L = 125 Ω C _L = 15 pF	—	0.15	—	μs
Turn-OFF delay	t _{OFF}	7	V _{CC} = V _{CC max} R _L = 125 Ω C _L = 15 pF	—	1.8	—	μs

5.4. Test Circuit

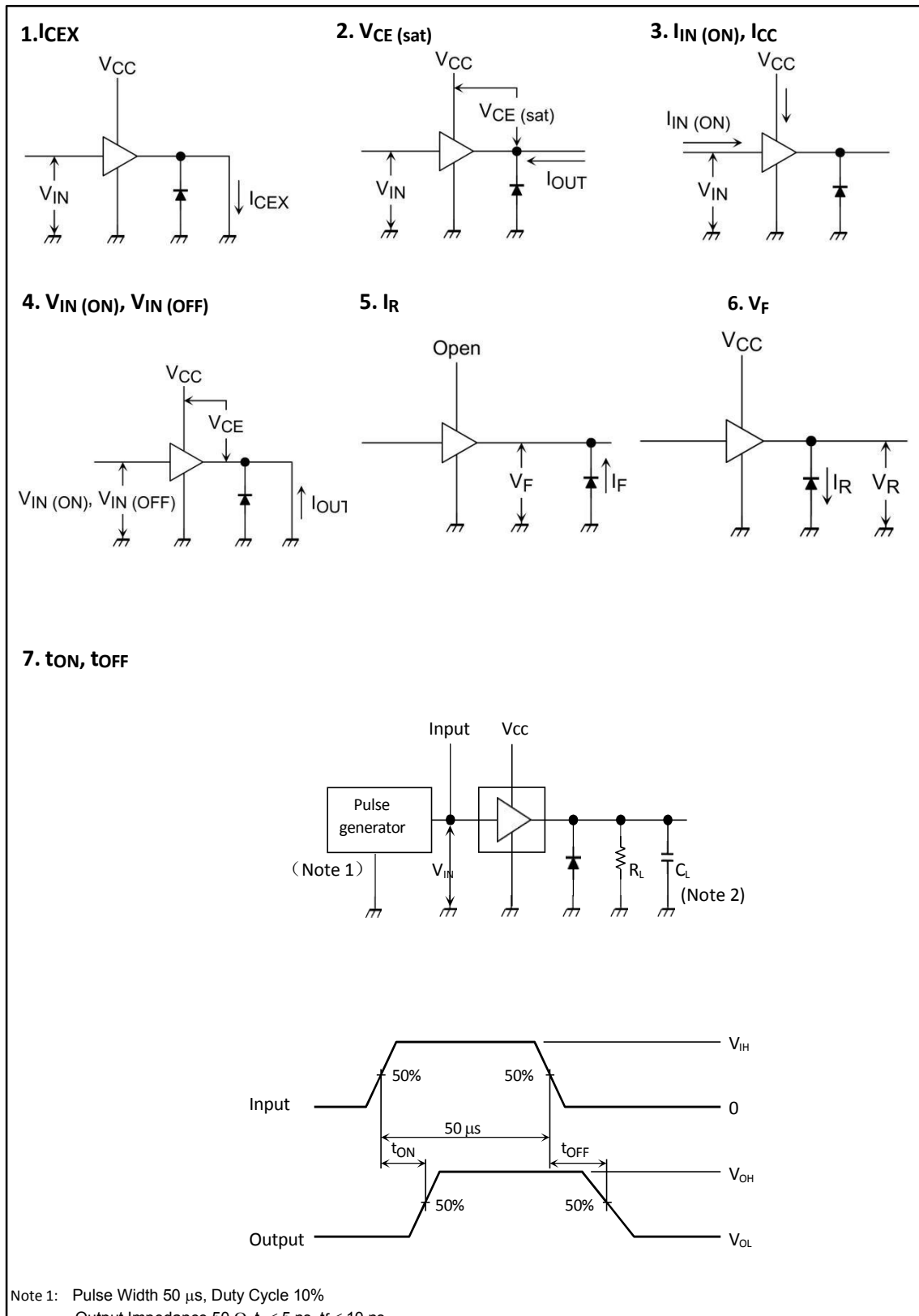

5.5. Precautions for Using

This IC does not integrate protection circuits such as overcurrent and overvoltage protectors.

Thus, if excess current or voltage is applied to the IC, the IC may be damaged. Please design the IC so that excess current or voltage will not be applied to the IC.

Utmost care is necessary in the design of the output line, VCC and GND line since IC may be destroyed due to short-circuit between outputs, air contamination fault, or fault by improper grounding.

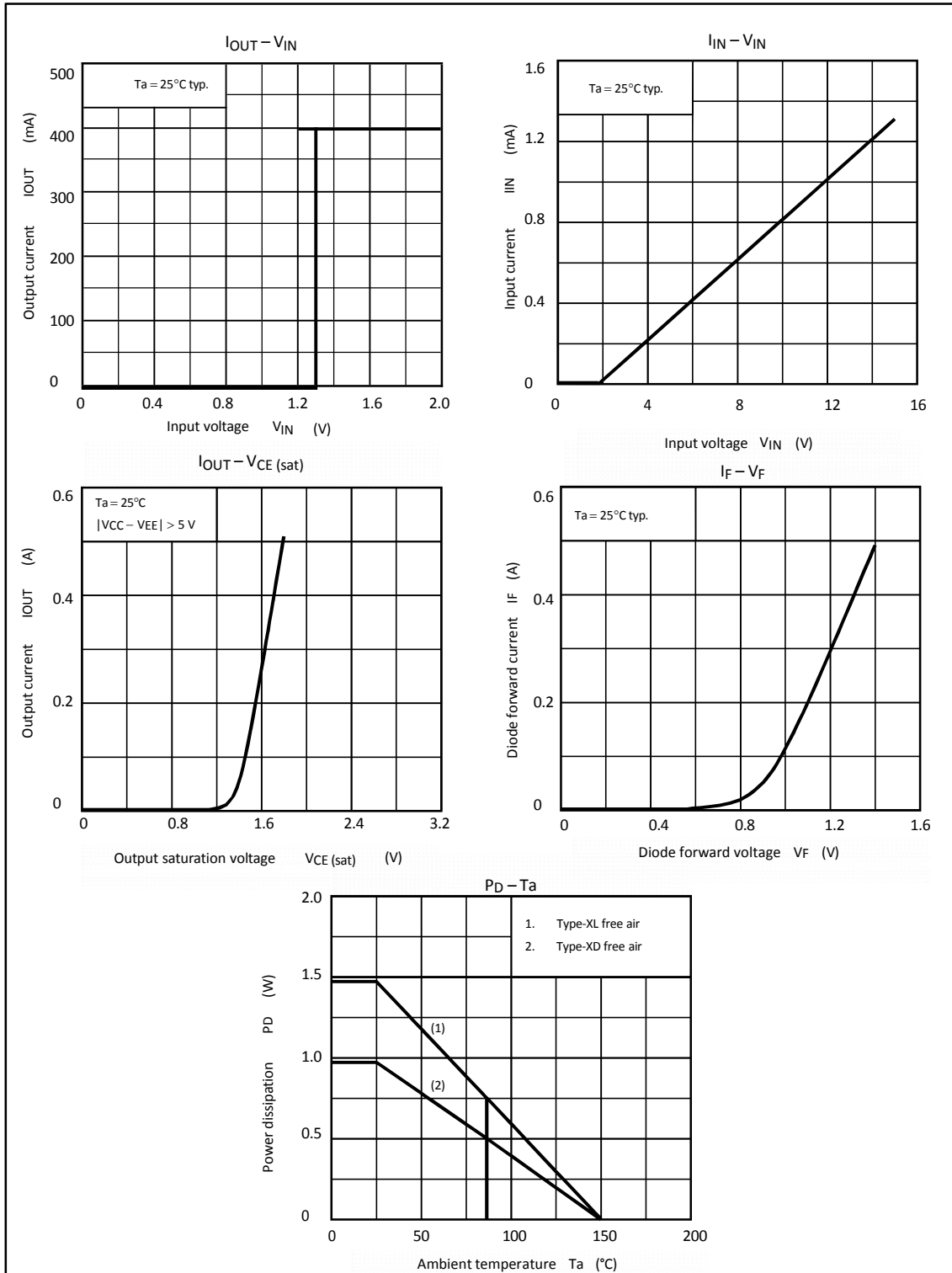

6. ORDERING INFORMATION

Ordering Information

Part Number	Device Marking	Package Type	Body size (mm)	Temperature (°C)	MSL	Transport Media	Package Quantity
XD62783	XD62783	DIP18	22.90 * 6.50	- 40 to 85	MSL3	Tube 20	800
XL62783	XL62783	SOP18	11.45 * 7.50	- 40 to 85	MSL3	T&R	1000

7. DIMENSIONAL DRAWINGS

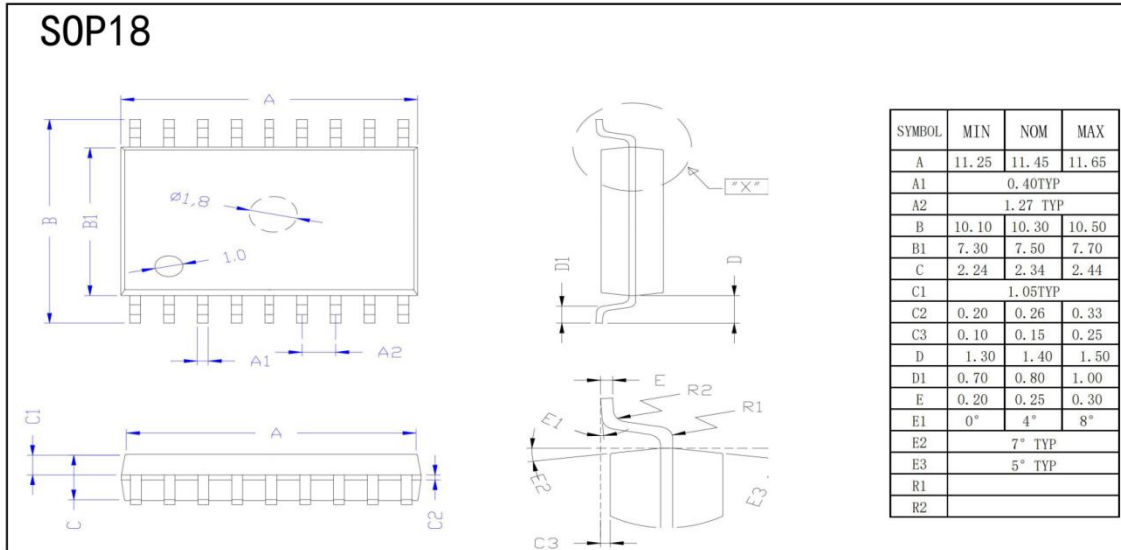

DIP18

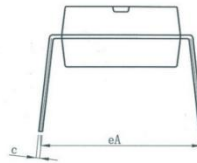
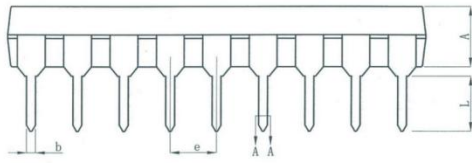

symbol	millimeter		
	Min	Nom	Max
A	3.20	3.30	3.40
b	0.44	—	0.53
b1	0.43	0.46	0.49
c	0.25	—	0.30
c1	0.24	0.25	0.26
D	22.80	22.90	23.00
E	6.40	6.50	6.60
e	2.54BSC		
eA	8.30	8.80	9.30
L	3.00	—	—

